

KING™, BULLDOG®, AND VISCOUNT® PUMP

Portable Cart

Model 218028

Pump Height: 33.5 in. (850.9 mm)
 Overall Height: 48 in. (1219 mm)
 Depth: 33 in. (838 mm)
 Width: 29 in. (737 mm)
 Weight: 72 lb (33 kg)

Ref. No.	Part No.	Description	Qty.
1	218027	FRAME, cart	2
2	179765	SUPPORT, pump	1
3	107144	SCREW, cap; 3/8-16 x 2-1/4"	8
4	179766	HANDLE, cart	1
5	100731	WASHER, flat; 3/8"	12
6	101566	LOCKNUT, hex; 3/8-16	8
7	179770	AXLE	1
8	154628	WASHER, flat; 3/4"	4
9	107146	RING, retaining, ext; 3/4"	4
10	112860	WHEEL, tire; pneumatic	2
11	107145	CAP, tube	2
14	100131	NUT, hex; 3/8-16	4
15	100133	LOCKWASHER, spring; 3/8"	4
16	100004	CAPSCREW; 3/8-16 x 1-1/4"	4
17	107410	BOLT, eye; 7/16-14 x 1-3/8", 1" ID	2
18	101213	NUT, hex; 7/16-14	2
19	100052	LOCKWASHER, spring; 7/16"	2

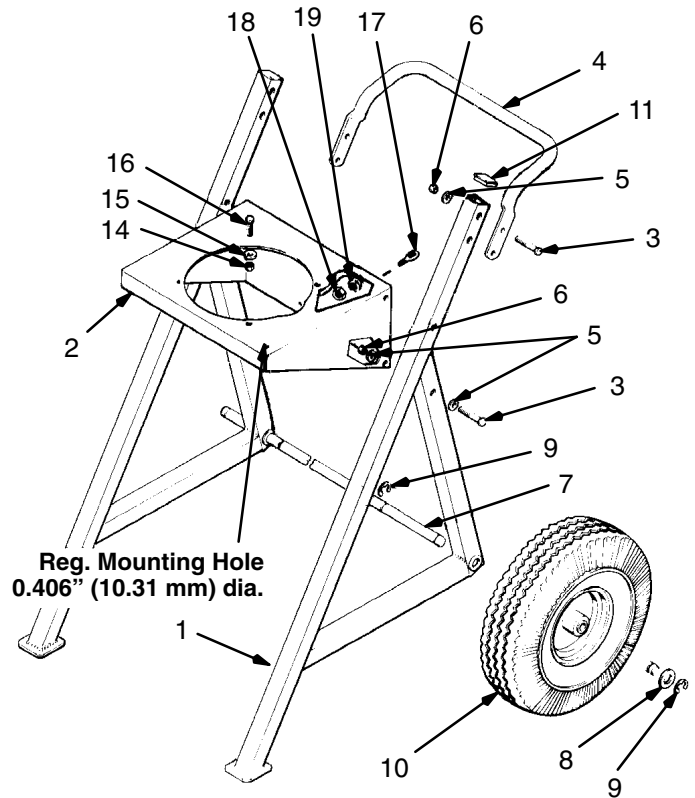

Order parts by name and number. Always give the model number of the assembly for which you are ordering.

Setup

1. Insert the axle (7) through the bushings of the cart frame (1) and install two of the four retaining rings (9) supplied in the axle grooves. See the parts drawing, above.
2. Install a wheel (10), washer (8), and retaining ring (9) on each end of the axle, as shown.
3. Insert the tube caps (11). Attach the handle (4) to the frame using the screws (3), washers (5) and locknuts (6).
4. Attach the eye bolts (17), lockwashers (19) and hex nuts (18) to the pump support. The suction tube will be threaded through the eye bolts. Attach the pump support to the frame using the screws (3), washers (5), and locknuts (6).

NOTE: This cart will mount King, Bulldog and Viscount II siphon-supply or stubby length pumps of lengths (not including the air motor) up to 33 in. (838 mm).

FIRE-BALL® PUMP

120 lb Portable Drum Cart

Model 222243

Overall Height: 46 in. (1168.4 mm)
Depth: 33 in. (838.2 mm)
Width: 29 in. (736.6 mm)
Weight: 75 lb (33 kg)

Ref. No.	Part No.	Description	Qty.
1	218027	FRAME, cart	2
2	183987	SHELF, drum	1
3	107144	SCREW, cap; 3/8-16 x 2-1/4"	4
4	179766	HANDLE, cart	1
5	100731	WASHER, flat; 3/8"	6
6	101566	LOCKNUT, hex; 3/8-16	6
7	179770	AXLE	1
8	154628	WASHER, flat; 3/4"	4
9	107146	RING, retaining, ext; 3/4"	4
10	112860	WHEEL, tire; pneumatic	2
11	107145	CAP, tube	2
12	100680	CAPSCREW; 3/8-16 x 7/8"	2
13	159016	BRACKET, retaining	2

Order parts by name and number. Always give the model number of the assembly for which you are ordering.

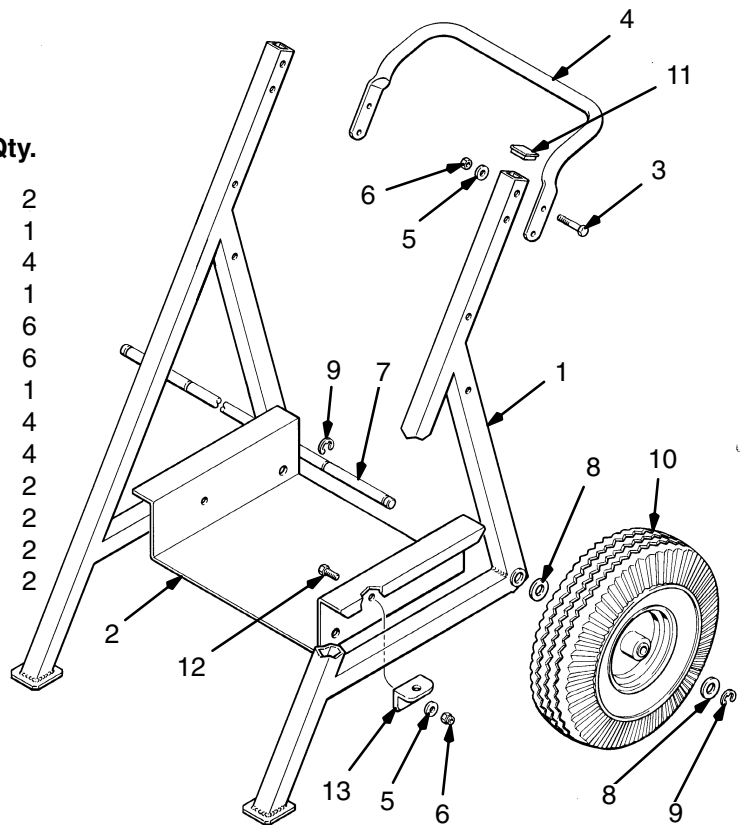

Setup

1. Insert the axle (7) through the bushings of the cart frame (1) and install two of the four retaining rings (9) supplied in the axle grooves. See the parts drawing, above.
2. Install a wheel (10), washer (8), and retaining ring (9) on each end of the axle, as shown.
3. Insert the tube caps (11). Attach the handle (4) to the frame using the screws (3), washers (5) and locknuts (6).
4. Attach the drum shelf (2) to the frame using the brackets (13), screws (12), washers (5), and locknuts (6).

NOTE: This cart will mount 120 lb grease drum Fire-Ball pumps, using 222061 Hold Down Kit and 222060 Drum Cover (must be ordered separately).

Sales Offices: Minneapolis, Detroit
Foreign Offices: Belgium, Korea, Hong Kong, Japan

GRACO INC. P.O. BOX 1441 MINNEAPOLIS, MN 55440-1441

PRINTED IN U.S.A. 307629 March 1983, Revised July 2003