

Pump Mounting Bracket

308394B

EN

Used to mount Dyna-Star or Power-Star pumps to a wall



Important Safety Instructions

Read all warnings and instructions in this manual and your pump manual. Save all instructions.

Model 236778

Includes hardware to mount to a stubby-size 1/4:1 ratio Dyna-Star™ Pump or a 1:1 Power-Star Pump™ to a wall.

Model 203987

Includes hardware to mount to a stubby-size 1:1 Dyna-Star, 1:1 Fast-Ball, 10:1 President, 3:1 Eagle, or 5:1 ration Fire-Ball Pump to a wall.

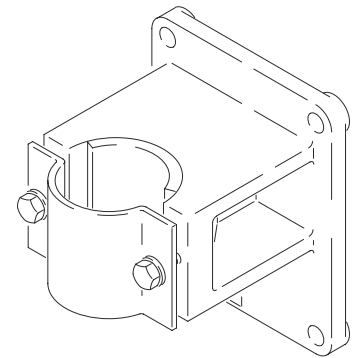

Installation

Mounting the Pump Bracket (FIG. 1)

1. When determining where to mount the bracket, consider the following things:
 - a. Location of the permanent supply lines from the pump to the outlet
 - b. Type of connections required
 - c. Ease in moving drums
 - d. Stress caused on the wall by the weight of the pump, pumping operation, hoses, and fluid
2. See FIG. 2. Refer to the following table for nominal screw size to mount the pump bracket. Use screw and lock washer of the appropriate type and length for your installation.

Model	Screw Size, in. (mm)
236778	1/2 (12)
203987	3/8 (10)

Dimensions

Model	X in. (mm)	Y in. (mm)	Z in. (mm)
236778	6-1/4 (159)	6-1/4 (159)	9/16 (14)
203987	4-1/8 (105)	5-1/8 (130)	7/16 (11)

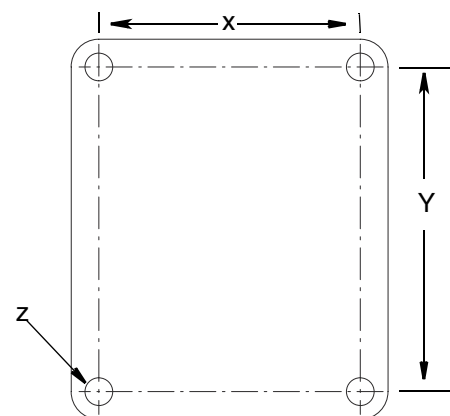

FIG. 1

Mounting the Pump (FIG. 2.)

1. Remove the screws (2), lock washers (1) and pump support strap (4).
2. Mount the pump in the pump mounting support (3) and position approximately 1 in. (25 mm) down the pump cylinder as showing in FIG. 2.
3. Reinstall the pump support strap, lock washers and screws.

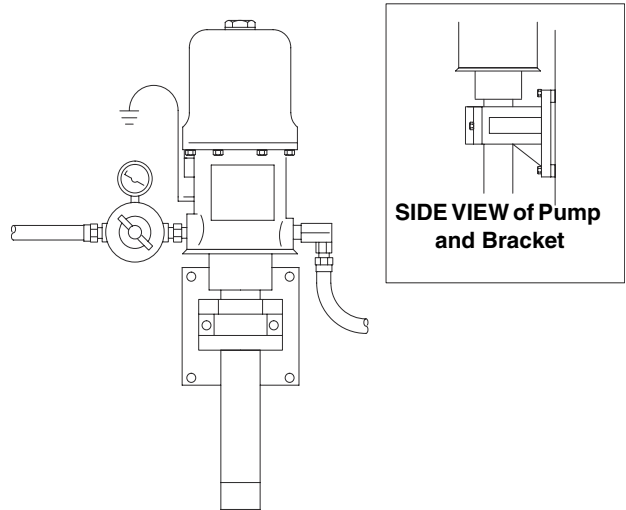
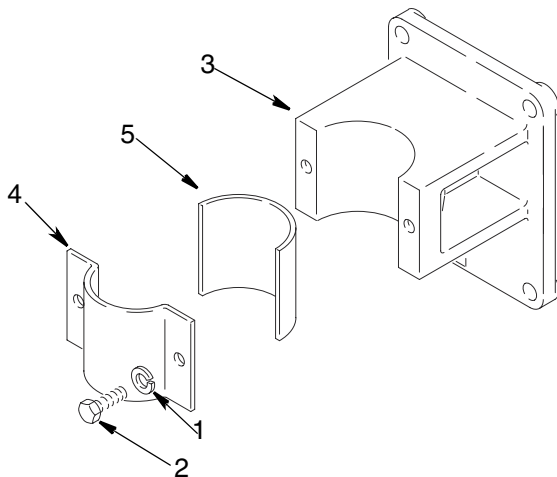

FIG. 2

Parts



Pump Mounting Bracket 236778

Ref No.	Part No.	Description	Qty.
1	100133	WASHER, lock; 3/8"	4
2	102637	SCREW, cap; 3/8- 16 x 1-1/2"	4
3	189713	SUPPORT, pump mounting	1
4	189721	STRAP, pump support	1
5	189836	PAD, pump mounting	1

Pump Mounting Bracket 203987

Ref No.	Part No.	Description	Qty.
1	100214	WASHER, lock; 5/16"	2
2	100450	SCREW, cap; 5/16-18 x 1"	2
3	160846	SUPPORT, pump mounting	1
4	160847	STRAP, pump support	1
5	168716	PAD, pump mounting	1

Graco Information

TO PLACE AN ORDER, contact your Graco distributor or call to identify the nearest distributor.

Phone: 612-623-6921 or Toll Free: 1-800-328-0211 Fax: 612-378-3505

FOR TECHNICAL ASSISTANCE, service repair information or answer about the application of Graco equipment: 1-800-543-0339
Toll Free

*All written and visual data contained in this document reflects the latest product information available at the time of publication.
Graco reserves the right to make changes at any time without notice.*

For patent information, see www.graco.com/patents.

Original instructions. This manual contains English. MM 308394

Graco Headquarters: Minneapolis
International Offices: Belgium, China, Japan, Korea

GRACO INC. AND SUBSIDIARIES • P.O. BOX 1441 • MINNEAPOLIS MN 55440-1441 • USA

Copyright 1994, Graco Inc. All Graco manufacturing locations are registered to ISO 9001.

www.graco.com

Revised August 2012