

Warm Melt Supply Systems

313296N

EN

For use with heated bulk supply of medium to high viscosity sealant and adhesive materials. Not for use in hazardous locations. Intended for indoor use only.

D60 3 inch dual post

60 liter (16 gallon), 30 liter (8 gallon), and
20 liter (5 gallon) sizes
150 psi (1.0 MPa, 10 bar) Maximum Air Inlet Pressure

D200 3 inch dual post

200 liter (55 gallon)
150 psi (1.0 MPa, 10 bar) Maximum Air Inlet Pressure

D200S 6.5 inch dual post

200 liter (55 gallon)
125 psi (0.9 MPa, 9 bar) Maximum Air Inlet Pressure



Important Safety Instructions

Read all warnings and instructions in this manual.
Save these instructions.

See page 4 for model information.

*The Graco Control Architecture Electric Components
are listed in Intertek's Directory of Listed Products.*

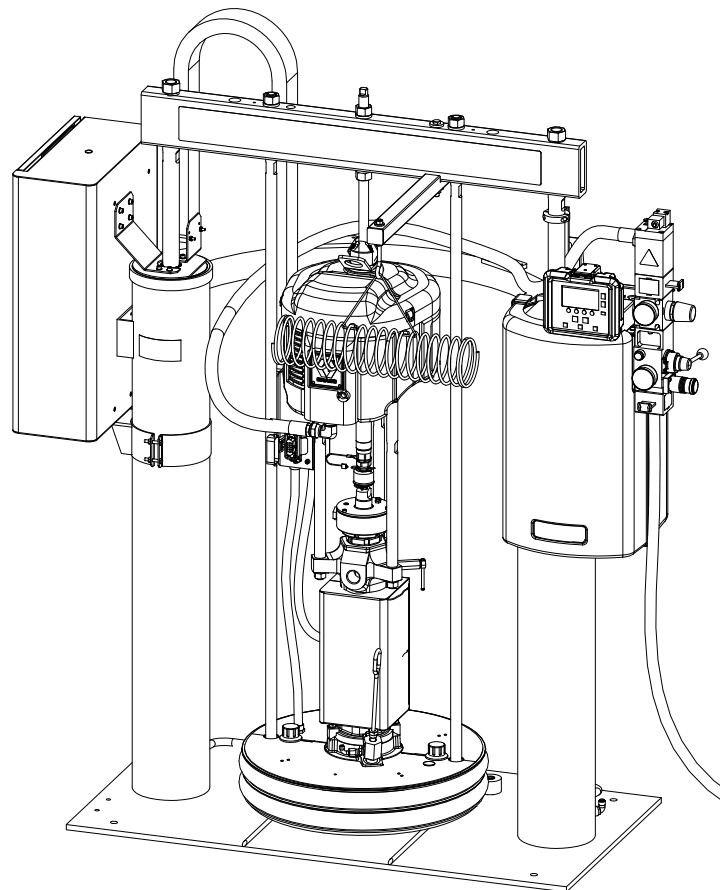

D200s (WM2179) Shown



Contents

Related Manuals	3	Repair	47
Models	4	Air Motor	47
Warnings	6	Displacement Pump	48
Overview	8	Disconnect Pump from Platen	50
System Description	8	Connect Pump to Platen	51
Power Requirements	8	Replace Pump Heaters	51
Heat Control Zone Selection	8	Replace Platen Heaters and Sensor	52
Component Identification	9	Replace Platen Wipers	54
Single Supply Systems	9	Replace Ram Piston Rod Seals	54
Tandem Supply Systems	10	Electrical Enclosure	55
Integrated Air Controls	11	Display/User Interface	58
Air Line Accessories	12	Replace Fluid Control Module	59
2-Button Interlock Air Controls	12	Replace Cable Track	60
Communications Gateway Module	12	Electrical Schematics	61
Fluid Control Module	13	Ram A Schematic	61
User Interface	14	D200 Single Ram Schematic	61
Installation	18	D200 Ram A Schematic	62
Location Requirements	18	D200 Ram B Schematic	63
Location	18	D200 Displacement Pump and Platen Schematics	64
Grounding	18	D200 Junction Box Schematic	65
Connect Power Source	19	D200 Cable Track Schematic	66
Install/Adjust Drum Low or Empty Sensor	20	D60 Single Ram Schematic	67
Light Tower Accessory	20	D60 Ram A Schematic	68
Attach Drum Stops	21	D60 Ram B Schematic	69
Check Resistance	22	D60 Pump and Platen Schematic	70
Hose Installation and Care	24	D60 Junction Box Schematic	71
Overview of Temperature Control Settings	24	D60 Cable Harness Schematic	72
Setup	25	Electrical Enclosure Schematic	73
Purge System	25	Electrical Enclosure Schematic	74
Set Values on Display Module	25	Parts	76
Load Material	26	Warm Melt Kits for D200 Systems	78
System Heat Up	27	Warm Melt Kits for D60 Systems	83
Prime	28	Electrical Enclosure Parts	90
Operation	29	Accessories	92
Pressure Relief Procedure	29	Appendix A - User Interface Display	93
Trigger Lock	29	Display Overview	93
Start and Adjust Ram	29	Display Details	93
Start and Adjust Pump	29	Setup Mode Screens	95
Automatic Crossover	30	Run Mode Screens	100
Manual Crossover	30	Dimensions	104
Recirculate Function	31	D200 Models	104
Depressurize Function	31	D60 Models	105
Change Drums	32	Technical Data	106
Shutdown	33	Graco Standard Warranty	108
Maintenance	33	Graco Information	108
Replace Throat Seals	33		
Platen Maintenance	34		
Electrical Enclosure	35		
Pump Heaters	36		
Alarms	37		
Diagnose Alarms	37		
Clear Alarms	37		
Alarm Codes and Troubleshooting	37		
Troubleshooting	44		

Related Manuals

Manuals are available at www.graco.com.

Component Manuals in U.S. English:

Manual	Description
313528	Tandem Supply Systems Operation
313529	Tandem Supply Systems Repair-Parts
313526	Supply Systems Operation
313527	Supply Systems Repair-Parts
312375	Check-Mate [®] Displacement Pumps Instructions-Parts
312376	Check-Mate [®] Pump Packages Instruction-Parts
312468	200 cc Check-Mate Displacement Pump Repair Parts
311238	NXT [™] Air Motor Instructions-Parts
312374	Air Controls Instructions-Parts
3A0099	Two-Zone Enclosure Expansion Kit Instructions-Parts
3A0100	Two-Zone and Four-Zone Enclosure Accessory Kits Instructions-Parts
3A0135	Bracket Mounting Kits Parts
312491	Pump Fluid Purge Kit Instructions
312492	Drum Roller Kit Instructions
312493	Light Tower Kit Instructions
309160	Heated Hose Instructions-Parts
312396	Hotmelt/Warm Melt Heated Fluid Regula- tor Instructions-Parts
307517	Mastic Fluid Regulator Instructions-Parts
309133	Pressure Compensating Valve Instructions-Parts
309181	Heated Header and Manifold Instructions-Parts
311209	Hot Melt Dispense Guns Instructions-Parts
310538	Therm-O-Flow [®] Automatic Dispense Valves Instructions-Parts
309376	EnDure [™] Automatic Dispense Valves Instructions-Parts
312864	Communications Gateway Module Instructions-Parts
313138	Supply System Communications Gate- way Module Installation Kit Instruc- tions-Parts
406681	Platen Cover Kit Instructions

Models

Check the identification plate (ID) for the 6-digit part number of your warm melt supply system. Use the following matrix to define the construction of your system, based on the six digits. For example, Part No. **WM2979** represents a Warm Melt supply system (**WM**), a carbon steel Check-Mate 200 Severe Duty® displacement pump with an NXT 3400 air motor (pump code **29**), a 6.5 in. dual post ram with integrated air controls (**7**) and a 55-gallon, uncoated platen with an EPDM seal (**9**).

NOTE: Some configurations in the following matrix cannot be built. See the Product Selection guide for available systems.

To order replacement parts, see **Parts** section in this manual and in manual 313527. The digits in the matrix do not correspond to the Ref. Nos. in the Parts drawings and lists.

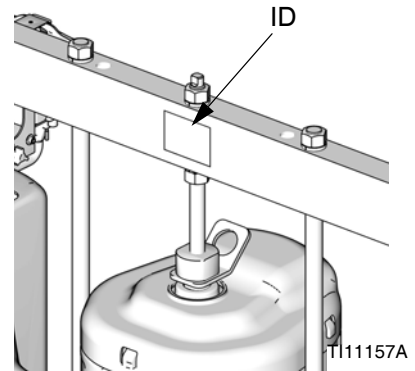

WM	29	7					9				
First and Second Digit	Third and Fourth Digit	Fifth Digit					Sixth Digit				
Pump Code	Ram Options	Platen and Seal Options									
		Size	Style	DataTrak Voltage	Air Controls	Platen Size	Platen Style	Platen Material	Seal Material		
WM (Warm Melt Single Supply System)	(See Table 1 for 2-digit Pump Code)	4	3 in.	D60	no volt	INT	F	20 L (5 Gal)	F, SW	SST	PTFE
		5	3 in.	D200	no volt	INT	H	20 L (5 Gal)	F, DW	CS	Polyurethane
		6	3 in.	D200i	no volt	INT	L	30 L (8 Gal)	F, SW	SST	PTFE
		7	6.5 in.	D200s	no volt	INT	R	30 L (8 Gal)	F, DW	CS	Polyurethane
		8	6.5 in.	D200si	no volt	2-Button Interlock	U	60 L (16 Gal)	F, SW	SST	PTFE
		Y	3 in.	D60i	no volt	2-Button Interlock	Y	60 L (16 Gal)	F, DW	CS	Polyurethane
		8						200 L (55 Gal)	DR	PTFE coated AL	EPDM
9						200 L (55 Gal)	DR	AL	EPDM		

TW	29	6	J
First and Second Digit	Third and Fourth Digit	Fifth Digit	Sixth Digit
Pump Code	Crossover Options	Platen and Ram Options	
		(See Table 2 for Platen and Ram Options)	
TW (Warm Melt Tandem Supply System)	(See Table 1 for 2-digit Pump Code)	6	Electric Crossover

- Key:**
 D = Dual post ram
 i = 2-Button interlock
 s = 6.5 in. ram
 INT = Integrated air controls
 F = Flat
 SW = Single wiper
 DW = Dual wiper
 DR = Dual o-ring

Table 1: Check-Mate Pump Identification Code/Part





Pump Code	Pump Part No. (see manual 312376)	Pump Code	Pump Part No. (see manual 312376)
NXT 2200/CM 200		NXT 6500/CM 200	
21	P23RCS	2L	P68RCS
22	P23RCM	2M	P68RCM
26	P23RSM	2U	P68RSM
NXT 3400/CM 200			
29	P36RCS		
2A	P36RCM		
2G	P36RSM		







Table 2: Platen and Ram Options

Sixth Digit	Ram Type	Platen Size	Platen Style	Seal Material
U	D60 (3" 60L)	60 Liter (16 Gallon)	SST, Heat, Dual Wiper	PTFE
X			CS, Heat, Dual Wiper	Polyurethane
0		30 Liter (8 Gallon)	SST, Heat, Dual Wiper	PTFE
K			CS, Heat, Dual Wiper	Polyurethane
I		20 Liter (5 Gallon)	SST, Heat, Dual Wiper	PTFE
6			CS, Heat, Dual Wiper	Polyurethane
J	D200 (3" 55 Gallon)	200 Liter (55 Gallon)	STD O-Ring	EPDM
A	D200s (6.5" 55 Gallon)		PTFE Coated O-Ring	EPDM
R			STD O-Ring	EPDM
F			PTFE Coated O-Ring	EPDM

Warnings

The following warnings are for the setup, use, grounding, maintenance, and repair of this equipment. The exclamation point symbol alerts you to a general warning and the hazard symbol refers to procedure-specific risk. Refer back to these warnings. Additional, product-specific warnings may be found throughout the body of this manual where applicable.

 WARNING	
	<p>ELECTRIC SHOCK HAZARD</p> <p>This equipment must be grounded. Improper grounding, setup, or usage of the system can cause electric shock.</p> <ul style="list-style-type: none"> • Turn off and disconnect power at main switch before disconnecting any cables and before servicing equipment. • Connect only to grounded power source. • All electrical wiring must be done by a qualified electrician and comply with all local codes and regulations.
	<p>FIRE AND EXPLOSION HAZARD</p> <p>Flammable fumes, such as solvent and paint fumes, in work area can ignite or explode. To help prevent fire and explosion:</p> <ul style="list-style-type: none"> • Use equipment only in well ventilated area. • Eliminate all ignition sources; such as pilot lights, cigarettes, portable electric lamps, and plastic drop cloths (potential static arc). • Keep work area free of debris, including solvent, rags and gasoline. • Do not plug or unplug power cords, or turn power or light switches on or off when flammable fumes are present. • Ground all equipment in the work area. • Use only grounded hoses. • Hold gun firmly to side of grounded pail when triggering into pail. • If there is static sparking or you feel a shock, stop operation immediately. Do not use equipment until you identify and correct the problem. • Keep a working fire extinguisher in the work area.
	<p>BURN HAZARD</p> <p>Equipment surfaces and fluid that's heated can become very hot during operation. To avoid severe burns:</p> <ul style="list-style-type: none"> • Do not touch hot fluid or equipment. • Wait until equipment/fluid has cooled completely.
	<p>SKIN INJECTION HAZARD</p> <p>High-pressure fluid from gun, hose leaks, or ruptured components will pierce skin. This may look like just a cut, but it is a serious injury that can result in amputation. Get immediate surgical treatment.</p> <ul style="list-style-type: none"> • Do not point gun at anyone or at any part of the body. • Do not put your hand over the dispense outlet. • Do not stop or deflect leaks with your hand, body, glove, or rag. • Follow Pressure Relief Procedure in this manual, when you stop dispensing and before cleaning, checking, or servicing equipment.

 WARNING	
	<p>MOVING PARTS HAZARD</p> <p>Moving parts can pinch or amputate fingers and other body parts.</p> <ul style="list-style-type: none"> • Keep clear of moving parts. • Do not operate equipment with protective guards or covers removed. • Pressurized equipment can start without warning. Before checking, moving, or servicing equipment, follow the Pressure Relief Procedure in this manual. Disconnect power or air supply.
	<p>SPLATTER HAZARD</p> <p>Hot or toxic fluid can cause serious injury if splashed in the eyes or on skin. During blow off of platen, splatter may occur.</p> <ul style="list-style-type: none"> • Use minimum air pressure when removing platen from drum.
	<p>TOXIC FLUID OR FUMES HAZARD</p> <p>Toxic fluids or fumes can cause serious injury or death if splashed in the eyes or on skin, inhaled, or swallowed.</p> <ul style="list-style-type: none"> • Read MSDS's to know the specific hazards of the fluids you are using. • Store hazardous fluid in approved containers, and dispose of it according to applicable guidelines. • Always wear impervious gloves when spraying or cleaning equipment. • If this equipment is used with isocyanate material, see additional information on isocyanates in Iso-cyanate Conditions Section of this manual.
	<p>EQUIPMENT MISUSE HAZARD</p> <p>Misuse can cause death or serious injury.</p> <ul style="list-style-type: none"> • Do not operate the unit when fatigued or under the influence of drugs or alcohol. • Do not exceed the maximum working pressure or temperature rating of the lowest rated system component. See Technical Data in all equipment manuals. • Do not leave the work area while equipment is energized or under pressure. Turn off all equipment and follow the Pressure Relief Procedure in this manual when equipment is not in use. • Check equipment daily. Repair or replace worn or damaged parts immediately with genuine manufacturer's replacement parts only. • Do not alter or modify equipment. • Use equipment only for its intended purpose. Call your distributor for information. • Route hoses and cables away from traffic areas, sharp edges, moving parts, and hot surfaces. • Do not kink or over bend hoses or use hoses to pull equipment. • Keep children and animals away from work area. • Comply with all applicable safety regulations.
	<p>PERSONAL PROTECTIVE EQUIPMENT</p> <p>You must wear appropriate protective equipment when operating, servicing, or when in the operating area of the equipment to help protect you from serious injury, including eye injury, inhalation of toxic fumes, burns, and hearing loss. This equipment includes but is not limited to:</p> <ul style="list-style-type: none"> • Protective eyewear • Clothing and respirator as recommended by the fluid and solvent manufacturer • Gloves • Hearing protection

Overview

System Description

Warm melt supply systems are used for melting and pumping warm melt adhesives and high viscosity sealants.

The system consists of an air-powered ram that drives a Check-Mate pump and a heated platen into a drum of material. The heated platen heats the material and the pump removes it from the drum. The material is then pushed through a supply hose to the applicator.

All features of the warm melt supply system are controlled by Graco Control Architecture components: Fluid Control Module (FCM), Temperature Control Modules (TCM), and the display module. The FCM controls the motor and pump, and the TCMs control the heaters. The display module provides the user interface for the entire warm melt supply system.

Power Requirements

A 30A (minimum) - 60A (maximum) circuit breaker (not provided) must be installed on the incoming power supply. See Table 1, and **Technical Data**, page 106, for more information regarding electrical requirements.

Table 1: Electrical Requirements

AC Panel Voltage	HZ	Phase	Full Load Amps
240	50/60	1	57.0

Heat Control Zone Selection

Warm melt supply systems have four heat zones (see FIG. 1).

- Zones 1 and 2 are always used for the heated platen and the heated pump respectively.
- Zones 3 and 4 are used for the heated hose and valve. These zones are rated for 1920 watts at 240 volts.

Heated hoses have a 16-pin connector on the inlet end cable, and an 8-pin connector on the outlet end cable. All heated valves, manifolds, and heaters are equipped with an 8-pin matching connector. Accessory cables are available for other possible combinations.

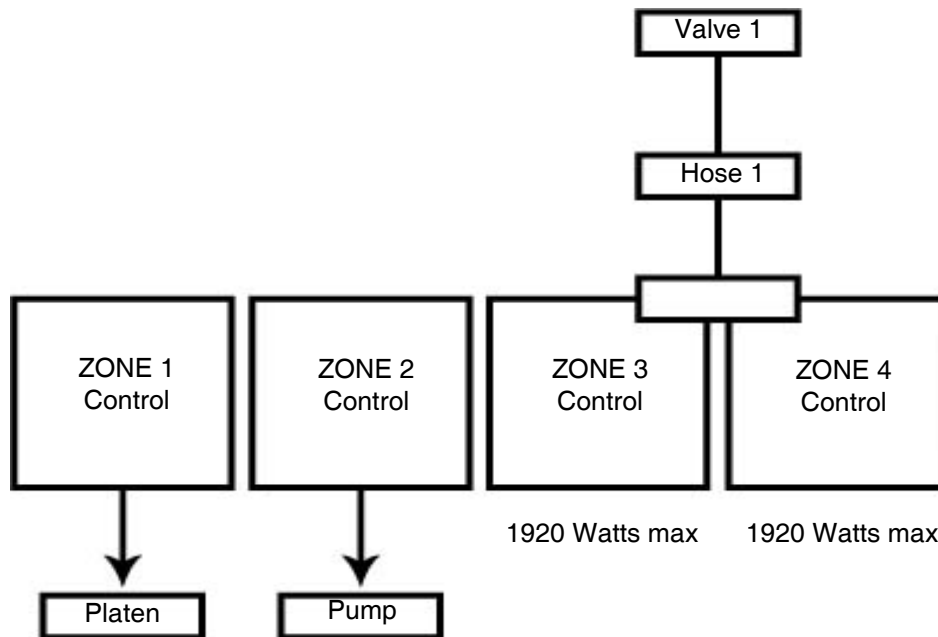

FIG. 1: Heat Control Zone Selection

Component Identification

Single Supply Systems

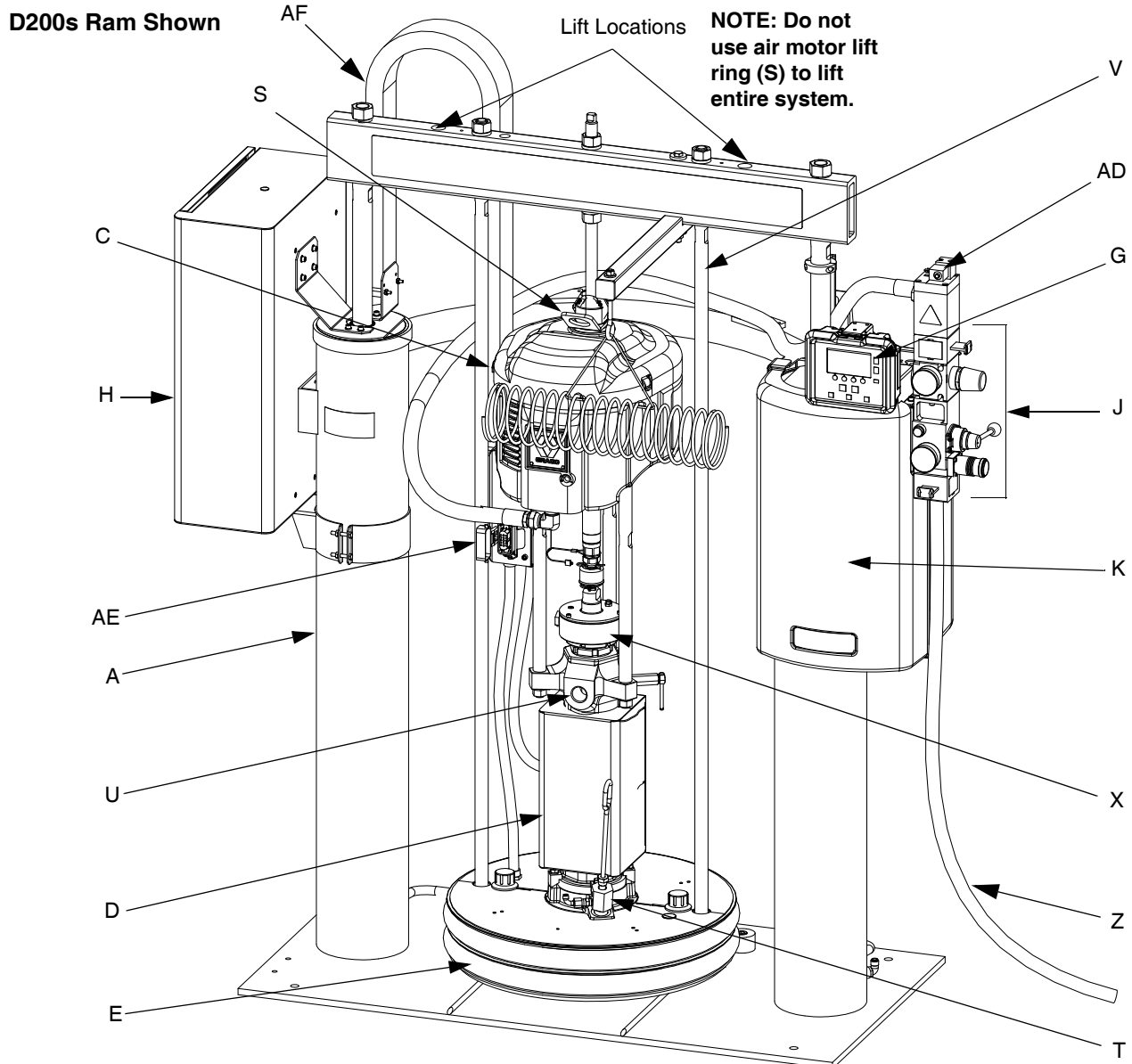

FIG. 2: Single Supply System

Key:

A	Ram Assembly	V	Platen Lift Rod
C	Air Motor	X	Wet Cup
D	Heated Check-Mate Displacement Pump	Z	Main Air Line (not supplied)
E	Heated Platen	AD	Air Motor Solenoid
G	Display Module	AE	Junction Box
H	Electrical Enclosure	AF	Cable Track
J	Integrated Air Controls (see FIG. 4)		
K	Fluid Control Module (inside shroud)		
S	Lift Ring (air motor)		
T	Platen Bleed Port		
U	Pump Outlet		

Tandem Supply Systems

D200s Rams Shown

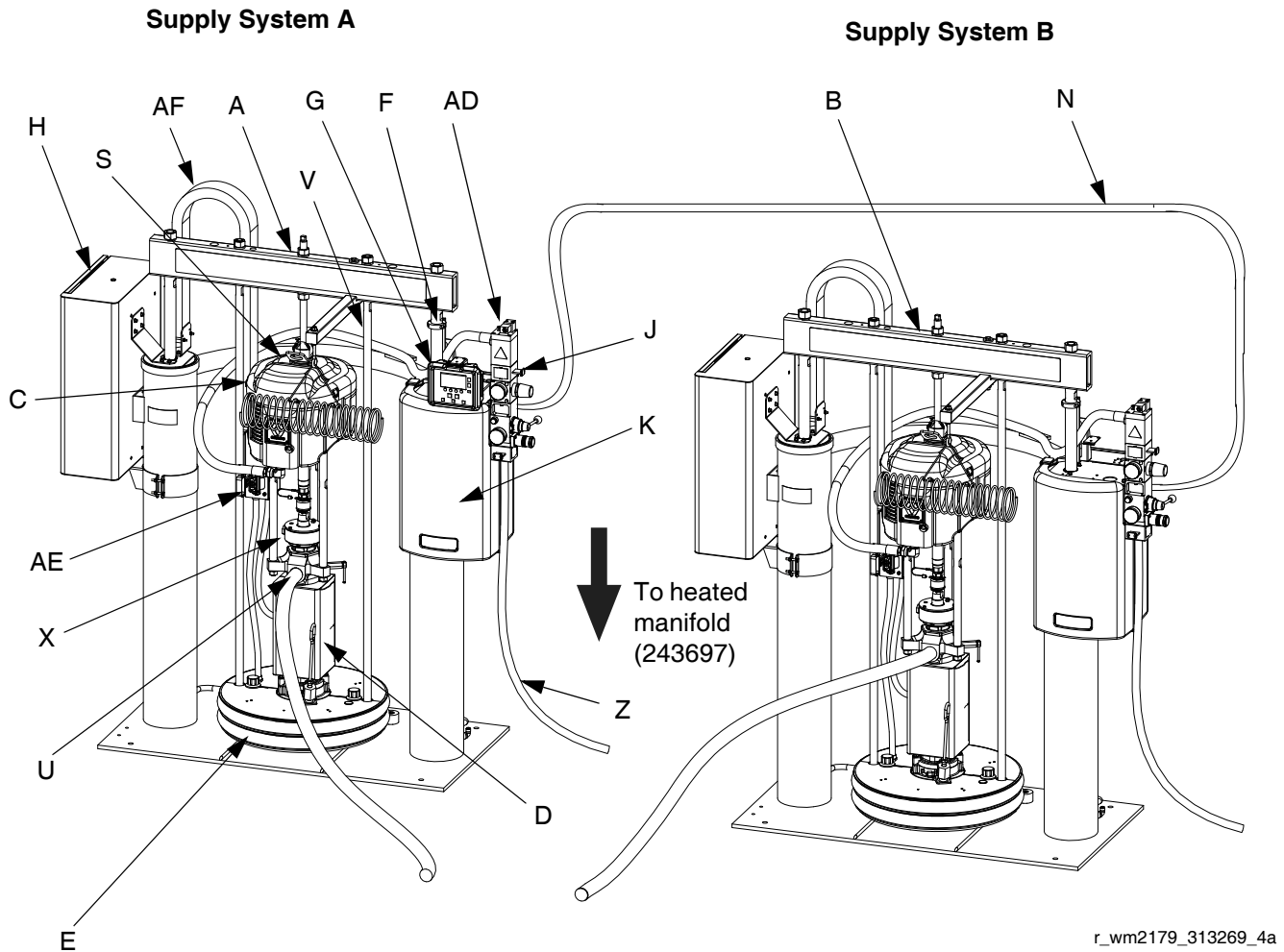

FIG. 3: Tandem Supply System

Key:

- | | | | |
|---|--|----|----------------------------------|
| A | Ram A | X | Wet Cup |
| B | Ram B | Z | Main Air Line (not supplied) |
| C | Air Motor | AD | Air Motor Solenoid (Ram A and B) |
| D | Heated Check-Mate Displacement Pump (Ram A and B) | AE | Junction Box (Ram A and B) |
| E | Heated Platen (Ram A and B) | AF | Cable Track (Ram A and B) |
| F | Drum Empty Sensor (partially hidden; Ram A and B) | | |
| G | Display Module (Ram A only) | | |
| H | Electrical Enclosure (Ram A and B) | | |
| J | Integrated Air Controls (Ram A and B); see page 11 | | |
| K | Fluid Control Module (inside shroud, Ram A and B) | | |
| N | CAN Communication Cable | | |
| S | Lift Ring (Air Motor) | | |
| T | Platen Bleed Port | | |
| U | Pump Outlet | | |
| V | Platen Lift Rod | | |

NOTE:

See FIG. 2 and FIG. 3. Before you install the system, you should be familiar with the following components.

Reference numbers and letters in parentheses in the text refer to the callouts in the figures.

Both rams (A and B) include a Check-Mate Pump (D), platen (E), integrated air controls (J), drum empty sensor (F), and fluid control module (K).

Only Ram A includes the display module (G).

- Drum empty sensor (F). Signals drum empty condition. See FIG. 11, page 20.
- Display module (G). Mounted on Ram A only. Provides Run Mode status screens, Setup screens, and control keys. See FIG. 8, page 14.
- Fluid control module (K). See FIG. 7, page 13.
- Integrated air controls (J). See FIG. 4.
- Air motor solenoid (AD). Solenoid is on when the selected ram is on and in Run Mode, Recirculate Mode, or Prime Mode. Solenoid is off when system is shut off or when in Depressurize Mode, or the ram is in an Inactive Ready Mode. The solenoid LED will illuminate when the solenoid is on.
- Depressurize/recirculate fluid valve. Depressurizes system when Depressurize Mode is active. Recirculates fluid when Recirculate Mode is active.

<p>To depressurize the system, press the Depressurize key on the display module and select when asked if you want to depressurize the system. Follow the Pressure Relief Procedure on page 29. Shutting off power or removing power from the system will not depressurize the system.</p>						

Integrated Air Controls

D60, D200, and D200s Models

The integrated air controls include:

- **Main air slider valve (BA)**: turns air on and off to the system. When closed, the valve relieves pressure downstream.
- **Ram air regulator (BB)**: controls ram up and down pressure and blowoff pressure.
- **Ram director valve (BC)**: controls ram direction.
- **Exhaust port with muffler (BD)**
- **Air motor regulator (BE)**: Controls air pressure to motor.
- **Air motor slider valve (BF)**: turns air on and off to the air motor. When closed, the valve relieves air trapped between it and the air motor. Push the valve in to shutoff. The air solenoid (AD), the air motor valve (BF), and the main air slider valve (BA) must be open for air to flow.
- **Blowoff button (BG)**: turns air on and off to push the platen out of an empty drum.

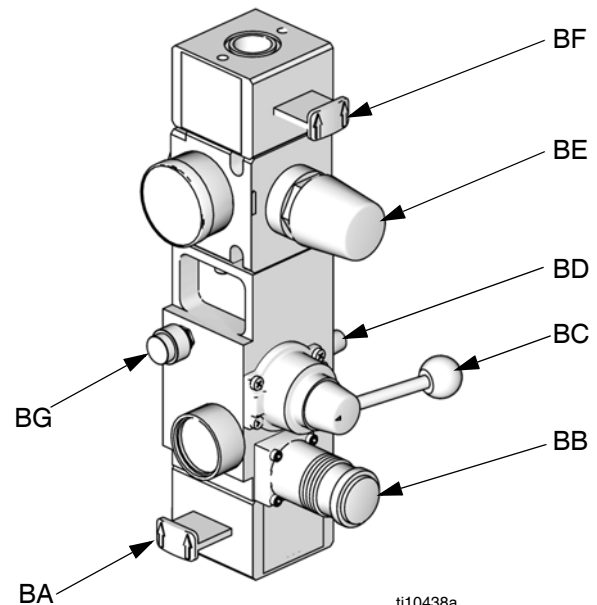

ti10438a

FIG. 4. Integrated Air Controls

Air Line Accessories

See Supply Systems Operation manual.

- **Air line drain valve.** Not included.
- **Air line filter:** removes harmful dirt and moisture from compressed air supply. Not included.
- **Second bleed-type air valve** isolates air line accessories and supply system for servicing. Locate upstream from all other air line accessories. Not included.
- **Air relief valve:** automatically relieves excessive pressure. Not included.

2-Button Interlock Air Controls

D60i, D200i, and D200si Models

Systems that have 2-Button Interlock controls have the following additional components:

- **2-Button Module:** See the Air Controls manual for information.
- **Roller switch (CA):** shuts off air supply when it contacts the bracket actuator. Operator must push and hold the activation buttons simultaneously to resume ram movement.

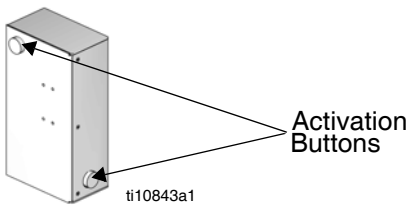

FIG. 5: 2-Button Module

- **Bracket actuator (CB):** attaches to the platen lift rod. When platen is outside of drum, actuator makes contact with the roller switch.

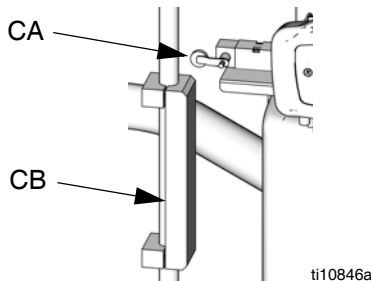

FIG. 6: Roller Switch and Bracket Actuator

Communications Gateway Module

The Communications Gateway Module (CGM) provides a control link between Graco Control Architecture based systems and a selected fieldbus. This provides the means for remote monitoring and control by external automation systems.

Data provided by the CGM to the fieldbus depends on which Graco Control Architecture based system and fieldbus are connected. A data map supplied on a map token is defined for this pairing. Once the data map has been loaded into the CGM, it is stored internally, and the map token is no longer required for operation.

See the Supply System Communications Gateway Module Installation Kit manual for fieldbus parameter setup instructions and screen descriptions.

CGM Module Status LED Signals

Signal	Description
Green on	System is powered up
Yellow	Internal communication in progress
Red Solid	CGM hardware failure
*Red (7 flashes)	Data map load failure
	Incorrect data map for fieldbus type
	No data map loaded

* The red LED will flash a code, pause, then repeat. See Communications Gateway Module manual 312864 for diagnostic information. Verify that you are using the correct token for your system and reinstall token. If fails, order new token.

Fluid Control Module

Table 2: FCM Sensor Connections

Connection	Ram	Sensor Description
1	Ram A and Ram B	Air motor solenoid (wire labeled 3), drum low (wire labeled 1), drum empty (wire labeled 2)
2	Ram A	Light tower
3	Ram A + B	Fluid depressurize/recirculate solenoid
4	not used	not used
5	Ram A and Ram B	Air motor reed switch, sensors
6	not used	not used
7	Ram A	Filter pressure at inlet and outlet
CAN communication cable 1	Ram A	From Ram A FCM to display module.
CAN communication cable 2	Ram A and Ram B	15 ft (4.57 m) from Ram A FCM to Ram B FCM.

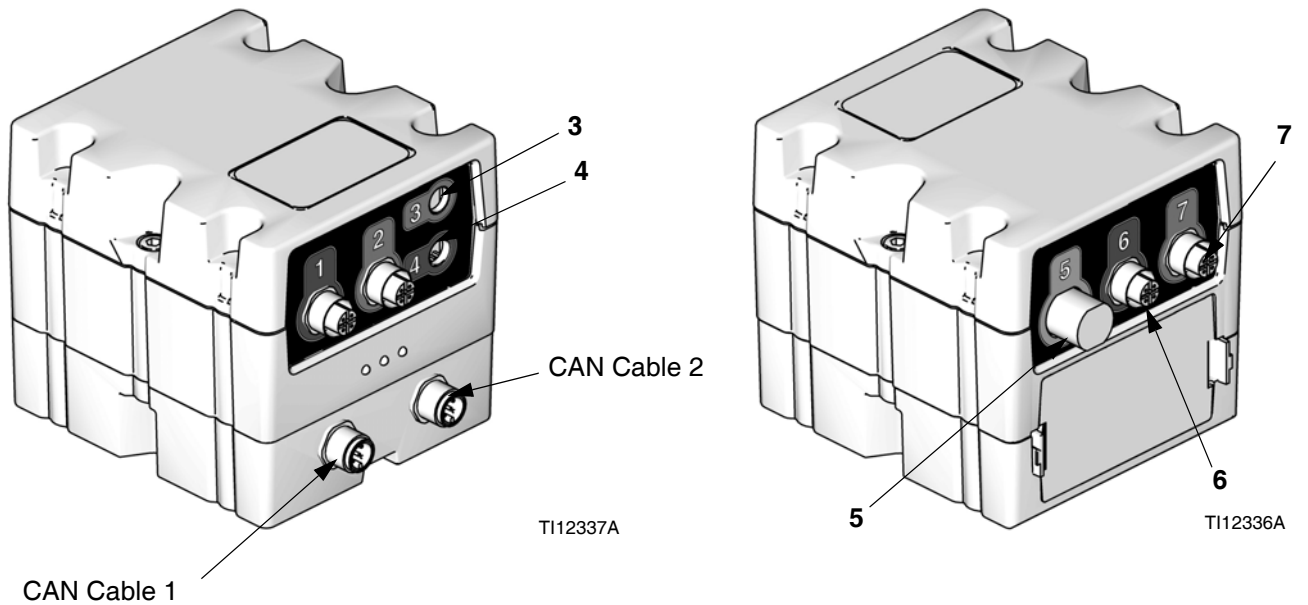

FIG. 7: FCM Sensor Connections

User Interface

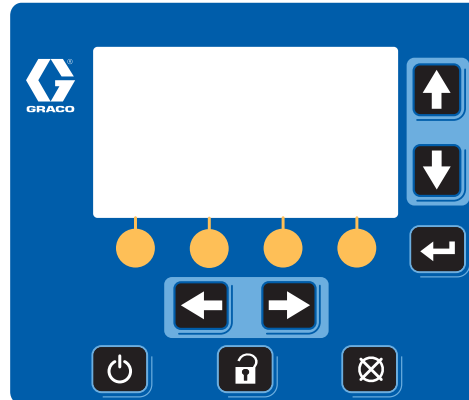

FIG. 8: Display Module

Table 3: Display Module Button Functions







Button	Function
On/Off 	Powers air motor solenoid ON and OFF from Ram Operation screen (FIG. 71, page 100).
	<ul style="list-style-type: none"> When ON, the air motor solenoid is ON and the pump of the active ram is pressurized. When OFF, the air motor solenoids are OFF.
	CAUTION: Turning the air motor solenoid OFF relieves pressure from the pump motor. It does not depressurize the fluid pressure. Follow the Pressure Relief Procedure , page 29.
	NOTE: The ram up/down and blowoff air is independent of the electronic controls and can be operated anytime the main air slider valve is open and air pressure is available.
	Powers heat ON and OFF from Heat Run screen (FIG. 72, page 101).
	<ul style="list-style-type: none"> When ON, the enabled heat zones are ON. When OFF, all heat zones are OFF.
Cancel 	Cancel a selection or number entry while in the process of entering a number or making a selection.
Setup 	Toggle between run and setup screens.
	<ul style="list-style-type: none"> Setup changes can be made while system is operating. If setup screens are password protected, button toggles between run and password entry screen.
Enter 	Opens drop down menus on Setup fields.
	Press to enter changes and make a selection.
Arrows Left/Right 	Navigate left or right to a new screen.
	Navigate left or right within a screen while in Jump In mode. See Appendix A - User Interface Display , page 93, for more information.
Arrows Up/Down 	Navigate up or down within a screen or to a new screen.
	<ul style="list-style-type: none"> Move between selections within a drop-down menu.
	<ul style="list-style-type: none"> Increment or decrement the selected numerical field within a selection menu.

Table 3: Display Module Button Functions

Button	Function
Soft Key 	Soft keys activate the mode or action represented by the icon above each button in the LCD. See Table 4 for soft key modes and actions.

Table 4: Display Soft Key Icons









Icon	Function
Depressurize 	Depressurize relieves fluid pressure from the pump outlet to below the platen on the currently active ram.
	If system is pressurized, press button.
	<ul style="list-style-type: none"> When prompted to depressurize the system, select <input checked="" type="checkbox"/> or <input type="checkbox"/>. Depressurizing the active ram will depressurize both rams. <p>NOTE: If additional user-supplied check valves have been added to the system, only the active ram will be depressurized. You must perform manual crossover and select depressurize again to depressurize both rams. See Crossover section of this table on page 16.</p>
	If system is depressurized, press button.
Pump Prime 	Pump Prime <ul style="list-style-type: none"> <i>Tandem ram:</i> if pump is off, activates the air solenoid on the active ram; <i>Tandem ram:</i> if pump is on, activates the air solenoid on the inactive ram which enables you to purge air and prime the pump; <i>Single ram:</i> activates air solenoid whether or not pump is on; clears the Pump Not Primed deviation or alarm (depending on setup selection); and resets the drum volume remaining to the drum fill volume setpoint for pump being primed.
	Press button.
	<ul style="list-style-type: none"> When prompted to prime the ram, select <input checked="" type="checkbox"/> to prime.
	Press button to exit Prime Mode or to reset counter to the prime time.
	<ul style="list-style-type: none"> When prompted to exit Prime Mode, select <input checked="" type="checkbox"/> to exit or <input type="checkbox"/> to reset prime counter.
Recirculate 	Recirculate Mode pumps fluid from the drum, through the pump, and back into the drum on the currently active ram.
	Set motor air regulator to 30 psi (0.2 MPa, 2.1 bar) before pressing Recirculate key.
	If system is not in Recirculate Mode, press button.
	<ul style="list-style-type: none"> When prompted to turn recirculation on, select <input checked="" type="checkbox"/> or <input type="checkbox"/>. Adjust motor air regulator to obtain desired flow rate.
	If system is in Recirculate Mode, press button.
<ul style="list-style-type: none"> When prompted to turn recirculation off, select <input checked="" type="checkbox"/> or <input type="checkbox"/>. 	

Table 4: Display Soft Key Icons

Icon	Function
<p>Crossover</p> 	<p>Crossover key transitions the active ram to inactive, and inactive ram to active. Available on Warm Melt Tandem Supply Systems only.</p> <p>NOTE: If an alarm is present on the inactive ram, crossover will not be successful. Manual crossover is disabled in single ram operation.</p> <p>Press button.</p> <ul style="list-style-type: none"> When prompted to initiate a crossover, select  or .
<p>Setback</p> 	<p>Setback transitions the heaters into setback mode. The setpoint for each zone will be decreased by the setback amount. See Heater System Setup Screen, page 96, and Heat Run Screen, page 101.</p>
<p>Jump In</p> 	<p>In screens that have editable fields, press  to access the fields and make changes. See Appendix A - User Interface Display, page 93, for more information.</p>

NOTICE

To prevent damage to soft key buttons, do not press the buttons with sharp objects such as pens, plastic cards, or fingernails.

User Interface Display

NOTE: For details regarding the user interface display see Appendix A - User Interface Display, page 93.

Display Screen Components

The following figure calls out the navigational, status, and general informational components of each display screen.

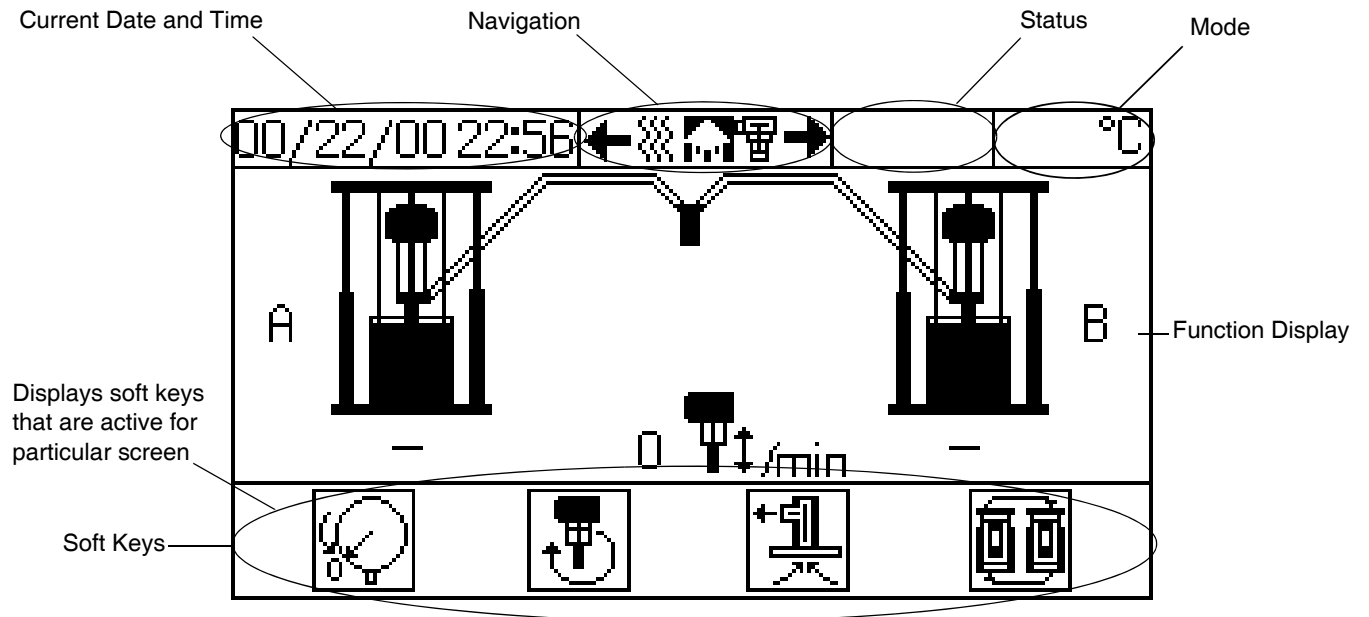

FIG. 9: Display Screen Components

Installation

Accessories are available from Graco. Make certain all accessories are adequately sized and pressure-rated to meet the system's requirements.

Component Identification illustrations are only a guide for selecting and installing system components and accessories. Contact your Graco distributor for assistance in designing a system to suit your particular needs.

Location Requirements

- Refer to **Dimensions**, page 104, for ram mounting and clearance dimensions.
- Install indoors only, and not near water or any other liquid that is sprayed.

Location

NOTICE

Always lift supply system at proper lift locations (see FIG. 2) to avoid equipment damage. Do **not** lift in any other way.

1. Attach a lifting sling at the proper lift spots. Lift off the pallet using a crane or a forklift. See FIG. 2 for proper lift locations.
2. Position the ram so the air controls and electrical enclosure are easily accessible. Ensure that there is enough space overhead for the ram to raise fully.
3. Using the holes in the ram base as a guide, drill holes for 1/2 in. (13 mm) anchors.
4. Ensure that the ram base is level in all directions. If necessary, level the base using metal shims. Secure the base to the floor using 1/2 in. (13 mm) anchors that are long enough to prevent the ram from tipping.

Grounding

Ground the supply system as instructed here and in the individual component manuals.

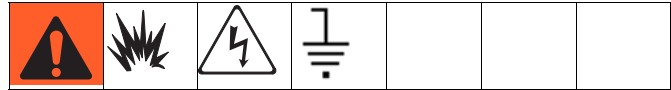

The power source conduit is not an adequate ground for the system. The unit must be bonded to either the building ground or a true earth ground. To reduce the risk of static sparking, ground the pump, the object being dispensed to, and all other dispensing equipment used or located in the dispensing area. All electrical wiring must be done by a qualified electrician and comply with local codes and regulations.

Pump: use a ground wire and clamp. Loosen grounding lug locknut and washer. Insert one end of supplied ground wire into slot in lug and tighten locknut securely. Connect other end of wire to a true earth ground. See FIG. 10.

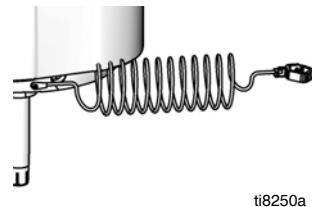

FIG. 10: Ground Pump

Air and fluid hoses: use only electrically conductive hoses.

Air compressor: follow manufacturer's recommendations.

Dispense valve: ground through connection to a properly grounded fluid hose and pump.

Fluid supply container: follow local code.

Object being sprayed: follow local code.

Solvent pails used when flushing: follow local code. Use only conductive metal pails, placed on a grounded surface. Do not place the pail on a nonconductive surface, such as paper or cardboard, which interrupts grounding continuity.

To maintain grounding continuity when flushing or relieving pressure: hold metal part of the dispense valve firmly to the side of a grounded metal pail, then trigger the valve.

Connect Power Source

The electrical enclosure comes already attached and wired to the ram; however, before the supply system becomes functional you must connect the electrical enclosure to a power source.

						
Have a qualified electrician connect power according to national, state, and local safety and fire codes.						

NOTE: Required voltage and amperage is noted on the electrical enclosure label. Also see Table 1. Before running power to the unit, make sure the plant electrical service meets the supply system's electrical requirements.

NOTE: See Power Requirements, page 8, for circuit protection requirements.

1. Open electrical enclosure door and locate power line filter.
2. Have a qualified electrician perform the following steps:
 - a. Connect your plant power to the electrical enclosure power line filter according to local codes. A 1-3/8 in. (35 mm) diameter opening is provided on the side of the enclosure adjacent to the label. This opening is suitable for a 1 in. npt conduit or strain relief fitting (supplied).
 - b. Connect a power protective ground to the center post on the line end of the power line filter.

NOTE: Install safety insulation boots (supplied) on the power line. Install 1/4 in. ring lugs (user supplied) on the power line and power protective ground line prior to connecting to the power line filter posts.

Install/Adjust Drum Low or Empty Sensor

1. Position ram at desired level (low or empty).

NOTE: Follow Steps 2 through 4 only if installing the low sensor.

2. Attach the low sensor to the existing sensor bracket (EA), above the existing empty sensor (EE).

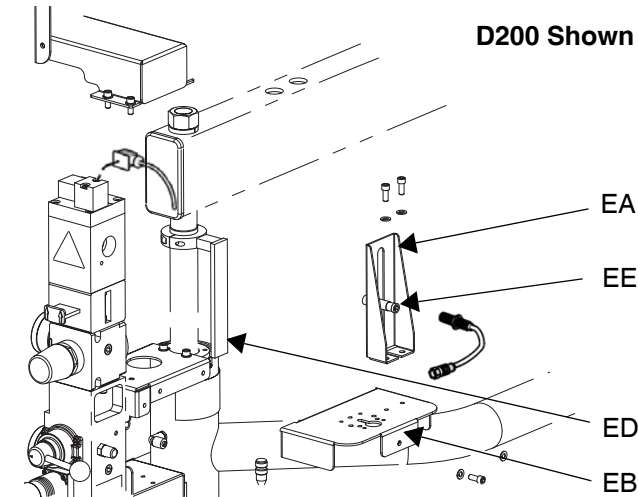

FIG. 11: Low or Empty Sensor Kit

3. Replace the existing cable between the empty sensor (EE) and FCM connector (see FIG. 7, page 13) with the empty/low sensor splitter cable.

4. Attach the sensor to the corresponding connector on the splitter cable. For drum low, attach the sensor to connector 1. For drum empty, attach the sensor to connector 2.
5. Power system on.
6. Make precise adjustments by moving the sensor within the slot on the sensor bracket. Use the yellow indicator on the sensor cable to indicate a drum low or empty condition.

Light Tower Accessory

Order the 255468 Light Tower Accessory as a diagnostic indicator for supply systems. See TABLE 5 for a description of light tower signals.

Table 5: Light Tower Signals

Signal	Description
Yellow flashing	A low priority error exists.
Yellow on	A medium priority error exists.
Red flashing	A high priority error exists.
Red on	The system is shut down due to error conditions.

Attach Drum Stops

Supply systems are shipped with drum stops in place to help position the drum on the ram. For replacement parts, order Kit 255477. The kit includes two each of capscrews (FA), lock washers (not shown), and drum stops (FB).

1. Locate the correct set of mounting holes on the ram base.
2. Using the capscrews (FA) and lock washers (not shown), attach the drum stops (FB) to the ram base.

D200 Shown

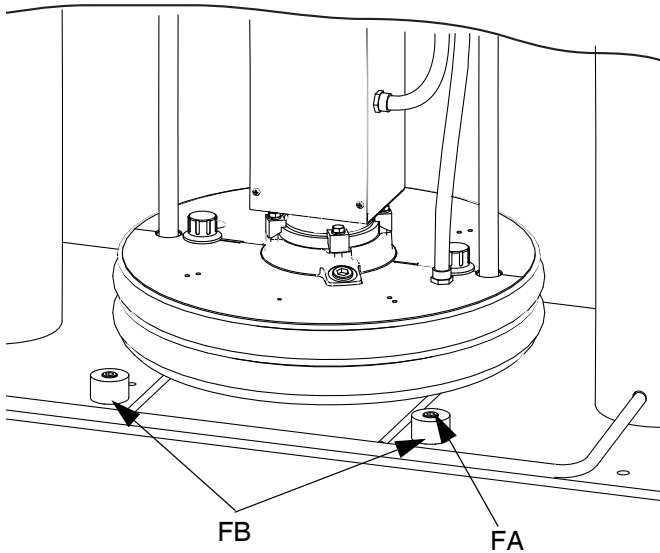

FIG. 12: Attach Drum Stops

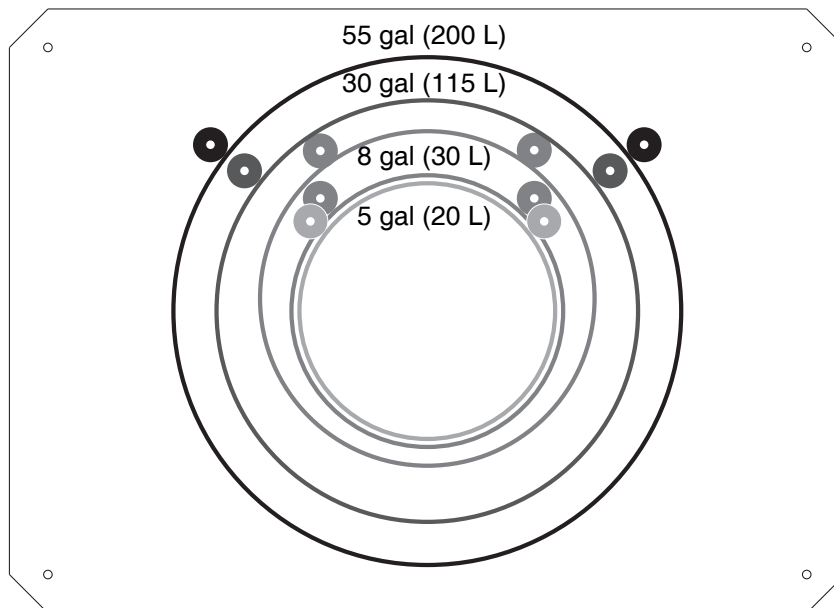



FIG. 13: Drum Stop Location

Check Resistance



Check the Resistance Between the Supply System and the True Earth Ground

					
<p>The resistance between the supply system components and true earth ground must be less than 0.25 ohms.</p>					

Have a qualified electrician check the resistance between each supply system component and the true earth ground. The resistance must be less than 0.25 ohms. If the resistance is greater than 0.25 ohms a different ground site may be required. Do not operate the system until the problem is corrected.

NOTE: Use a meter that is capable of measuring resistance at this level.

Sensor Resistance Checks

						
<p>Conduct these electrical checks with the main disconnect OFF.</p>						

NOTE: For dispense valve and hose sensor resistance checks, refer to your dispense valve manual or hose manual.

The supply system includes a heat sensor and controller for each of the four heated zones. To check sensor resistance:

1. Make sure the power is off and that the disconnect switch is in the OFF position.
2. Make electrical resistance checks for the components.
3. Replace any parts that have resistance readings that do not comply with the ranges listed in Table 6.

NOTE: Check resistance at ambient room temperature (63°– 77°F [17°– 25°C]).

Table 6: RTD Sensor Resistance

Zone	Component	Connector Pin	Range (ohms)
1	Platen	Pin 1 to 3	1050-1100 Ω
2	Fluid Pump	Pin 1 to 3	1050-1100 Ω

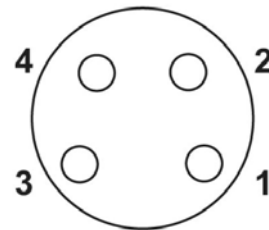
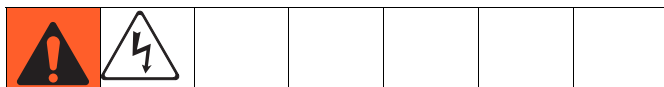

FIG. 14: RTD Connector Pins

Heater Resistance Checks



Conduct these electrical checks with the main power disconnect OFF.

NOTE: For dispense valve and hose sensor resistance checks, refer to your dispense valve manual or hose manual.

To check heater resistance:

1. Make sure the power is off and that the disconnect switch is in the OFF position.
2. Make electrical resistance checks for the components. Refer to Table 7. Heater terminal pins are located on the back of the enclosure (H). See FIG. 2, page 9.
3. Replace any parts whose resistance readings do not comply with the ranges listed in Table 7.

NOTE: Check resistance at ambient room temperature (63°– 77°F [17°– 25°C]).

Table 7: Resistance Chart of All Heaters

Zone	Component	Between Terminals	Unit Voltage	Range (ohms)
1	Platen - D200	1 and 3	240	15 +5/-5
2	Platen - D60	1 and 3	240	80 +10/-10
3	Pump	L and N	240	37 +5/-5

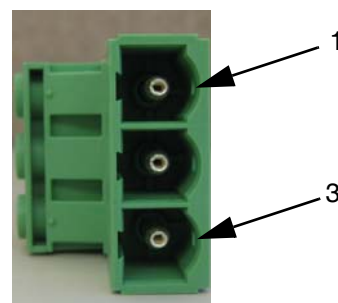
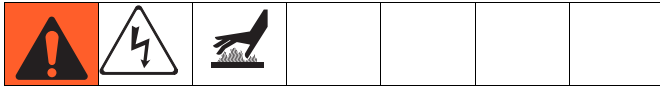

FIG. 15: Heater Terminal Pins

Hose Installation and Care



NOTE: The warm melt supply system requires Graco single-circuit material hoses rated at a maximum of 1920 Watts.

Hose Installation

1. Connect heated hose to the pump outlet.
2. Use two wrenches to tighten. Torque to 470-550 in-lbs (53.1-62.1 N•m).

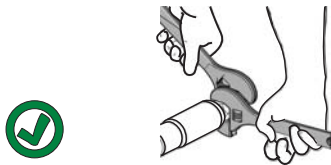

3. Wrap exposed fittings on the pump outlet with Nomex insulation and secure insulation using fiberglass tape.
4. Connect hose adapter to green receptacle on junction box.

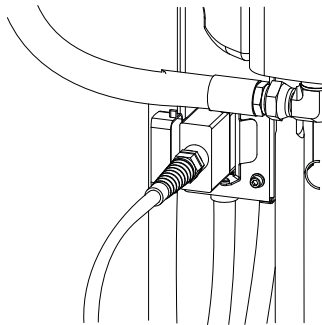

FIG. 16: Connect Hose to Junction Box

5. Securely tighten the 16-pin electrical connectors on long heated hose leads into 16-socket receptacles on the end of the hose adapter.
6. Securely tighten the 8-socket electrical connectors on short heated hose leads into 8-pin receptacle located on the dispense valves.

Hose Care Guidelines

Refer to the Hotmelt/Warm Melt Heated Hose manual for details regarding hose care guidelines.

Mechanical Setup

1. Fill displacement pump wet cup 2/3 full with Graco Throat Seal Liquid (TSL).
2. Turn all air regulators to their full counterclockwise position.
3. Connect a 3/4 in. (19 mm) air line from an air source to the system air inlet. Refer to the pump performance curves in the Check-Mate Pump Packages manual to determine your air supply flow requirements.

NOTE: Quick disconnects restrict flow for large air motors.

Overview of Temperature Control Settings

Temperature controls are set in Setup mode. See **Setup Mode Screens** on page 95 for information about setting temperature controls.

See **Run Mode Screens** on page 100 for information on controlling temperatures for each zone.

Setup

The pump was tested with lightweight oil, which is left in the fluid passages to protect parts. To avoid contaminating fluid with oil, flush the pump with a compatible solvent before use. See **Purge System**, step 2.

Purge System





Purging the system before the initial use can prevent material contamination, which may cause the material to fail or perform poorly.





NOTICE

Purge the system before performing the initial **material loading procedure**. The system was factory-tested using a light soluble oil, a soybean oil, or some other oil as tagged. Flush the system to avoid contaminating the material that has been designated for initial material loading.

To purge the system perform the following procedure:

1. Select the material for the initial material load.
2. Verify whether the factory-test oil and the initial material load are compatible:
 - a. If the two substances are compatible, omit the remaining steps in this procedure and refer to the start up and operation instructions.
 - b. If the two substances are incompatible, perform the remaining steps in this procedure to flush the system at ambient temperature.

						
Use fluids that are chemically compatible with the equipment wetted parts. See the Technical Data sections in the equipment manuals.						

						
This equipment should not be used with more than one type of fluid due to potential compatibility issues that could result in an unpredictable reaction. Graco recommends using new hoses when chemicals are changed or care must be taken to assure that all traces of one chemical are removed before introducing a second chemical.						

3. Select a container of material that can eliminate the factory-test oil from the system. If necessary, check with Graco or the material supplier for a recommended solvent.
4. Before purging ensure the entire system and waste container are properly grounded.



NOTE: Remove any dispense valve orifices before purging. Reinstall after purging has been completed.

5. Purge the material through the system for approximately 1 to 2 minutes.
6. Remove the container if purge material was used.

Set Values on Display Module

Set desired values on display module Setup menus. See **Setup Mode Screens**, page 95.

Load Material

						
<p>Moving parts can pinch or amputate fingers. When the pump is operating and when raising or lowering the ram, keep fingers and hands away from the pump intake, platen, and lip of the drum.</p>						

NOTICE

Do not use a drum of material that has been dented or otherwise damaged; damage to the platen wiper can result.

NOTE: Before loading material, ensure that there is a minimum overhead clearance of 105 in. (267 cm) and all air regulators are backed off to their full counterclockwise position.

NOTE: Follow steps below for both rams if using a tandem warm melt supply system.

1. Refer to FIG. 2, FIG. 3, and FIG. 4. Close all air regulators and air valves.
2. Open main air slider valve (BA) and set ram air regulator (BB) to 40 psi (0.28 MPa, 2.8 bar). Set director valve handle (BC) to UP and let the ram rise to its full height. **2-Button Interlock:** If the system has this feature, ram will stop as it nears the top. Press and hold both buttons to raise ram completely. See FIG. 5 on page 12.
3. Lubricate the platen seals (D) with grease or other lubricant compatible with the fluid you will pump.
4. Remove the drum cover and smooth the surface of the fluid with a straightedge.
5. Put a full drum of fluid on the ram base, slide it back against the drum stops, and center it under the platen (D). An optional drum roller kit is available to make it easier to load the drum on the base. Order Kit 255627.
6. Remove bleed stick from platen bleed port (J). See FIG. 17.
7. If drum has a plastic liner, pull it over edge of drum. Secure liner with tape wrapped around circumference of drum.

D200 Shown

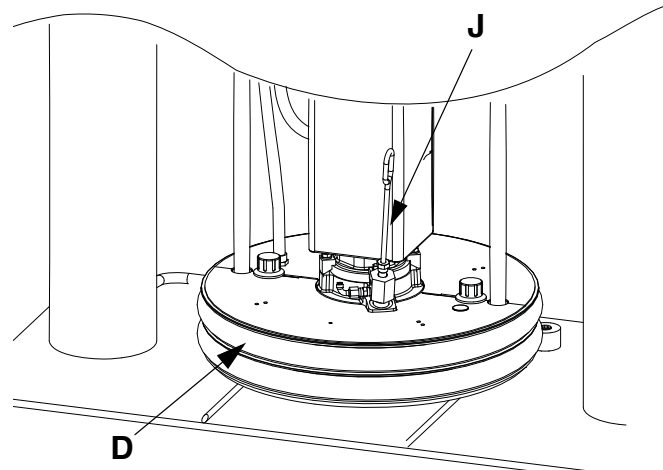





FIG. 17: Heated Platen

8. Set the director valve (BC) to DOWN and lower the ram until fluid appears at the top of the platen bleed port (J). Adjust ram air regulator (BB) as needed. Set the director valve (BC) to neutral and close the platen bleed port (J). **2-Button Interlock:** If system has this feature, press and hold both buttons to start lowering the ram. See FIG. 5, page 12.

System Heat Up

						
---	---	---	---	--	--	--

Never pressurize warm melt supply system while using warm melt materials before turning on heat.

Many warm melt materials tend to expand when heating and may cause a heated hose to burst. Avoid the potential of bursting a hose by opening the dispense valve during system heat up and lock the dispense valve trigger open every time you shut the system down.

NOTE: Operate at the lowest temperature and pressure necessary for your application.

1. Turn the main disconnect on the electrical control panel door to the ON position.
2. Press  while in the Heat Run screen to turn the heaters on for enabled heat zones.

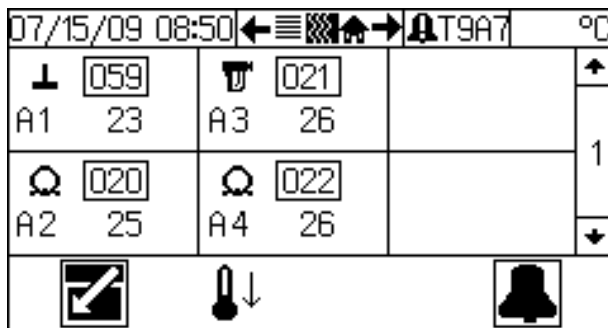

FIG. 18: Heat Run Screen - Ram A

Prime



1. Make sure the system is at required temperature.
2. **Tandem Systems Only:** To prime the active ram, ensure that the system is not in Run Mode. To prime the inactive ram, ensure that the system is on and in Run Mode.
3. **Single Systems Only:** To prime the ram, ensure that the system is on. The system may or may not be in Run Mode.

(Prime active ram - not Run Mode)

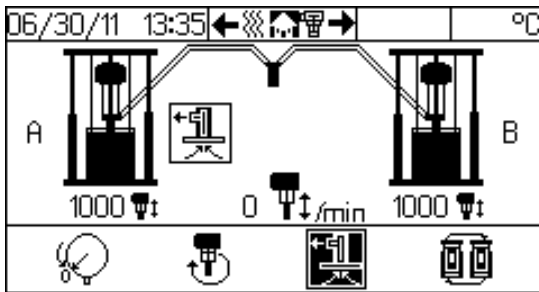

FIG. 19: Ram Operation Screen - Tandem System

(Prime inactive ram - in Run Mode)

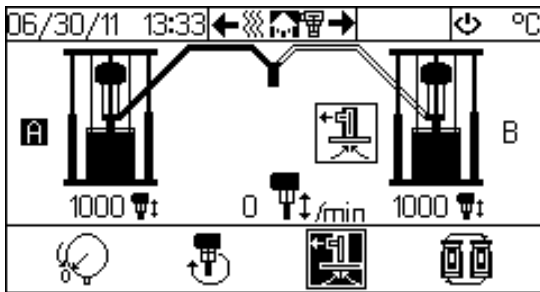



FIG. 20: Ram Operation Screen - Tandem System

4. If using a manual dispense valve, unlock the dispense valve trigger and place dispense valve over a waste container.
5. Press the Pump Prime key . The display prompts the operator to confirm. See FIG. 21. Select  to begin prime.

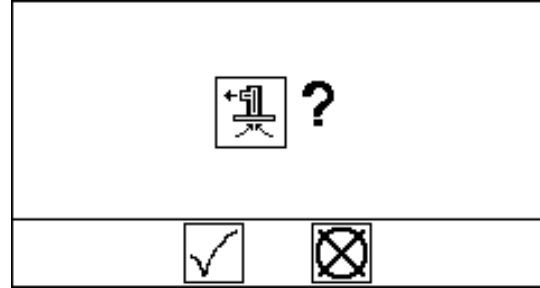



FIG. 21: Prime Confirmation

6. When the timer expires the air motor solenoid LED will turn off.
7. Prime the system until a smooth flow of material dispenses from the dispense valve.
8. Lock the dispense valve trigger lock.

NOTE: To exit Prime Mode before the timer expires, press the Pump Prime key . The display prompts the operator to confirm. See FIG. 22. Select  to exit prime.

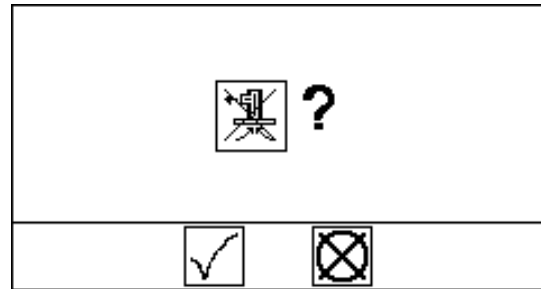



FIG. 22: Exit Prime Mode Confirmation

NOTE: To extend the prime time counter, select  in FIG. 22. Display prompts operator to confirm. See FIG. 23. Select  to reset.

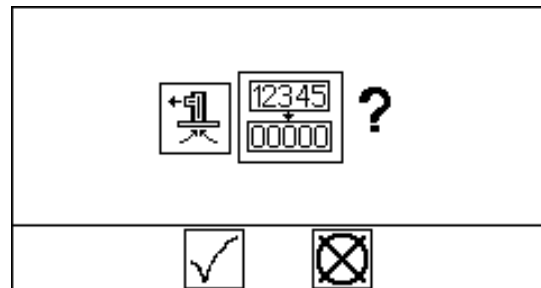

FIG. 23: Reset Prime Time Counter Confirmation

Operation

Pressure Relief Procedure



This procedure describes how to relieve pressure for the supply system. Use this procedure whenever you shut off the system and before checking or adjusting any part of the system.

1. Lock the dispense valve trigger.
2. Press On/Off key . If system is On, display will highlight . Select to turn off.

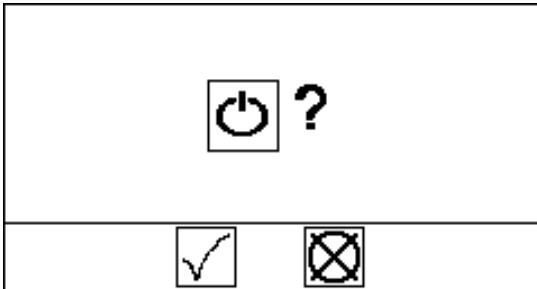

FIG. 24: System Function Screen

3. See FIG. 4, page 11. Close the air motor slider valve (BF) and the main air slider valve (BA) on ram(s).
4. Set the ram director valve to DOWN. The ram will slowly drop.
5. Jog the director valve up and down to bleed air from ram cylinders.
6. Unlock the dispense valve trigger.
7. Hold a metal part of the dispense valve firmly to the side of a grounded metal pail, and trigger the dispense valve to relieve pressure.
8. Lock the dispense valve trigger.
9. Open all fluid drain valves on ram(s). Have a container ready to catch the drainage. Leave fluid drain valves open until ready to dispense again.

If you suspect that the dispense tip/nozzle or hose is completely clogged, or that pressure has not been fully relieved after following the steps above, very slowly loosen the tip guard retaining nut or hose end coupling and relieve pressure gradually, then loosen completely. Now clear the tip/nozzle or hose.

Trigger Lock

Always engage the trigger lock when you stop dispensing to prevent the gun from being triggered accidentally by hand or if dropped or bumped.

Start and Adjust Ram

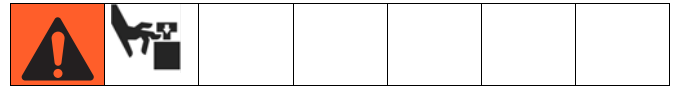

Moving parts can pinch or amputate fingers. When the pump is operating and when raising or lowering the ram, keep fingers and hands away from the pump intake, platen, and lip of the drum.

To start and adjust the ram(s), follow the **Load Material** procedure on page 26.

Start and Adjust Pump

NOTE: Follow steps below for both pumps if using a tandem warm melt supply system.

1. Connect pump outlet fittings and hose (not supplied).

NOTE: Be sure all components are adequately sized and pressure rated to meet the system's requirements.

2. Be sure the pump air valve is closed. Then set the ram air regulator (BB) to 50 psi (0.35 MPa, 3.5 bar). Set the director valve (BC) to DOWN. See FIG. 4, page 11.

- Press  while in the Ram Operation screen.

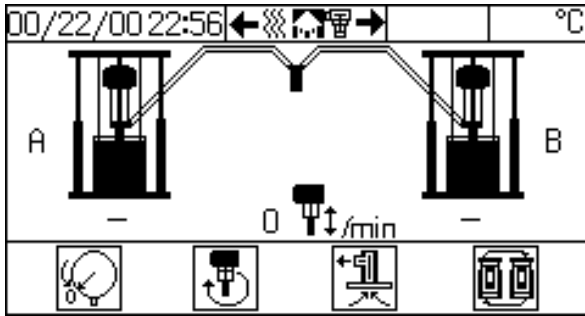



FIG. 25: Ram Operation Screen - Tandem System

- When the confirmation screen appears with a prompt, select  to start the pump.
- Open the pump air valve (BF) and keep the director valve (BC) set to DOWN while pump is operating.

NOTE: Increase air pressure to the ram if the pump does not prime properly with heavier fluids. Decrease air pressure if fluid is forced out around the top seal or platen.

Automatic Crossover

(Tandem Supply System Only)



Keep clear of the inactive ram, as automatic crossover may occur unexpectedly. To repair or adjust the ram, first follow all steps of the **Pressure Relief Procedure** on page 29.

The automatic crossover feature allows continuous flow and prevents system shutdown. If the active ram encounters a pump runaway or drum empty alarm, it will attempt an automatic crossover to the inactive ram.

The system will generate a crossover error if the active ram attempts an automatic crossover while the inactive ram has a pump runaway, drum empty, or not primed alarm. If this occurs, correct the error and clear the alarm from the Alarm screen. See **Alarm Screen**, page 103, for details.



Manual Crossover

(Tandem Warm Melt Supply System Only)

Manual crossover can only be initiated if the following conditions are met:

- inactive ram is not in the drum empty error condition.
- pump runaway and not primed alarms do not exist.

To initiate a manual crossover to the inactive ram:

- From the Ram Operation screen, press the Crossover key . The display prompts the operator to confirm.
- Select  to confirm manual crossover operation or select  to cancel.

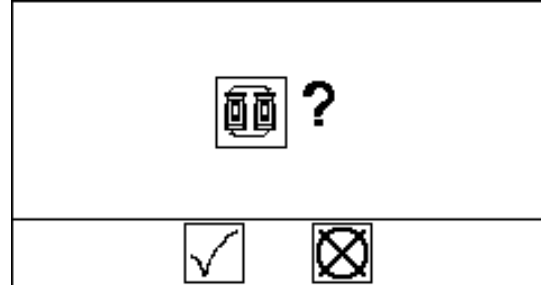





FIG. 26: Crossover Function Screen

NOTE: If the active ram has a pump runaway error or drum empty error, the system will attempt an automatic crossover.

Recirculate Function

Recirculate mode pumps fluid from the drum, through the pump, and back into the drum on the currently active ram.

To enter Recirculate mode:

1. Set the motor air regulator to 30 psi (0.2 MPa, 2.1 bar).
2. From the Ram Operation screen, press the Recirculate key . The display prompts the operator to confirm.
3. Select  to confirm recirculation or select  to cancel.

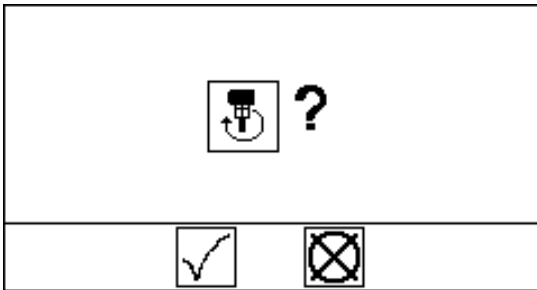

FIG. 27: Enter Recirculate Mode

4. Adjust motor air regulator to obtain desired flow rate.



NOTE:

While in Recirculate Mode, the manual crossover function cannot be used and the inactive ram cannot be primed.

To exit Recirculate Mode, press the Recirculate key



. The display prompts the operator to confirm.

Select  to confirm or select  to cancel. See FIG. 27.

NOTE:

You must exit Recirculate Mode before depressurizing or initiating a crossover.



Depressurize Function



Follow the **Pressure Relief Procedure** on page 29. Shutting off power or removing power from the system will not depressurize the system.

When the system is pressurized the depressurize function relieves fluid pressure from the pump outlet to below the platen on the currently active ram. However, when the system is depressurized pressing the depressurize key will restore fluid pressure.

Depressurize System

From the Ram Operation screen, press the Depressurize key . The display prompts the operator to confirm. Select  to confirm depressurize or select  to cancel.

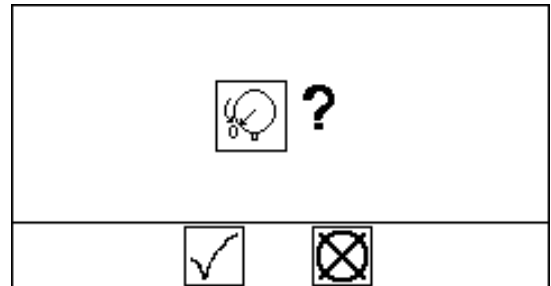





FIG. 28: Depressurize Function Screen

NOTE:

Depressurizing the active ram will depressurize both rams. However, if additional user-supplied check valves have been added to the system, only the active ram will be depressurized.

To depressurize both rams perform manual crossover (see Manual Crossover, page 30), and then press the Depressurize key  again.

Pressurize System

From the Ram Operation screen, press the Depressurize key . The display prompts the operator to confirm. Select  to confirm pressurize or select  to cancel. See FIG. 28.

Change Drums









NOTE: Follow this procedure to change the drum on a fully heated warm melt supply system.

NOTE: Follow this procedure for either ram if using a tandem warm melt supply system.

NOTICE
Do not use a drum of material that has been dented or otherwise damaged; damage to the platen wiper can result.

1. Push in the air motor slider valve (BF) to stop the pump. See FIG. 4.
2. Set ram director valve (BC) to UP to raise the platen (D) and immediately press and hold the blowoff air button (BG) until the platen (D) is completely out of

drum. Use minimum amount of air pressure necessary to push the platen out of the drum.

						
Excessive air pressure in the material drum could cause the drum to rupture, causing serious injury. The platen must be free to move out of the drum. Never use drum blowoff air with a damaged drum.						

3. Once the platen clears the drum, release the blow-off air button (BG) and allow the ram to rise to its full height. **2-Button Interlock:** If system has this feature, the ram will stop as it nears the top. Press and hold both buttons to raise ram completely. See FIG. 5.
4. Remove empty drum.
5. Inspect platen and, if necessary, remove any remaining material or material build-up.
6. Place full drum on ram base.
7. Lower the ram and adjust the position of the drum relative to the platen. See **Load Material** on page 26.





Shutdown

Follow the procedure below for normal system shut down, such as at the end of the work day.

NOTICE

Turning the system OFF relieves pressure from the pump motor; however, it does not depressurize the fluid pressure. Follow the **Pressure Relief Procedure**, page 29.

NOTE: The ram up/down and blowoff air is independent of the electronic controls and can be operated anytime the main air slider valve is open and air pressure is available.

1. Press  while in the Ram Operation screen to turn off the air motor. Select  to confirm.
2. Press  while in the Heater Run screen to turn off the heaters. Select  to confirm.
3. Follow the **Pressure Relief Procedure**, page 29.



Many warm melt materials tend to expand when heating and may cause a heated hose to burst. Avoid the potential of bursting a hose by opening the dispense valve during system heat up and lock the dispense valve trigger open every time you shut the system down.

Maintenance



To reduce the risk of serious injury whenever you are instructed to relieve pressure, always follow the **Pressure Relief** procedure.

Replace Throat Seals

Quick Coupler

Remove wet cup from displacement pump while attached to the ram to replace throat seals.

1. Ensure displacement pump is at bottom of stroke.
2. Follow the **Pressure Relief Procedure** on page 29.
3. Remove Quick Coupler:
Remove clip (GC), and slide coupling cover (GB) to remove coupling (GA).

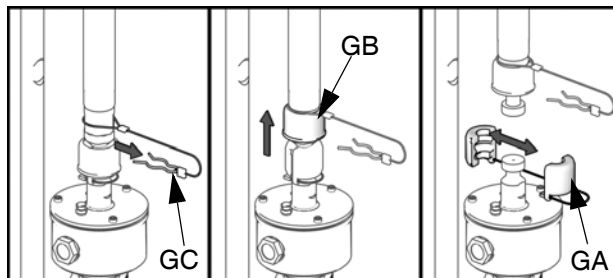

ti10508a

FIG. 29: Remove Quick Coupler

4. Lift air motor rod to bring rod to top of stroke.
5. Remove wet cup and packing cartridge according to instructions in displacement pump manual(s).

Platen Maintenance



If the platen does not come out of the pail easily when the pump is being raised, the air assist tube or check valve may be plugged. A plugged valve prevents air from reaching the underside of the plate to assist in raising it from the pail.

1. Turn off main disconnect.
2. Relieve pressure and disassemble air assist valve. Refer to Supply Systems Repair-Parts manual.
3. Clear air assist tube in platen. Clean all parts of valve and reassemble. Refer to Supply Systems Repair-Parts manual.
4. Remove bleed stick from platen. Push bleed stick through bleed relieve port (T) to remove material residue. See FIG. 30.
5. Remove platen covers. See FIG. 30.
 - a. Remove platen cover fasteners (70) or nuts (309).
 - b. *For 55 gallon platen (D200 3 in. and D200s 6.5 in. supply systems):* Remove both platen covers (49) and ground wire from platen.

For smaller platens (D60 3 in. supply systems):
Disconnect pump for the platen; see **Disconnect Pump from Platen**, page 50. Remove screws (323) from upper heater plate (320). Remove upper heater plate.
6. Remove any excess fluid. Use a soft wire brush on heater coils (48) or heater (319). See FIG. 30.
7. Inspect platen heater blocks (43 or 320) or heater (48 or 319) for burn or melt spots. Replace platen heater blocks or heater if necessary. See FIG. 30.
8. Check for loose connections and damaged wires.
9. Follow steps in reverse order to reassemble platen.

NOTE: Torque platen cover fasteners (70) to 60 +/- 10 in-lbs (6.8 +/- 1.1 N•m) for 55 gallon platen. Torque nuts (309) to 45 +/- 5 in-lbs (5.1 +/- 0.6 N•m) for smaller platens.

Remove and Reinstall Platen Wipers

Refer to **Supply Units Repair-Parts** manual for instructions.

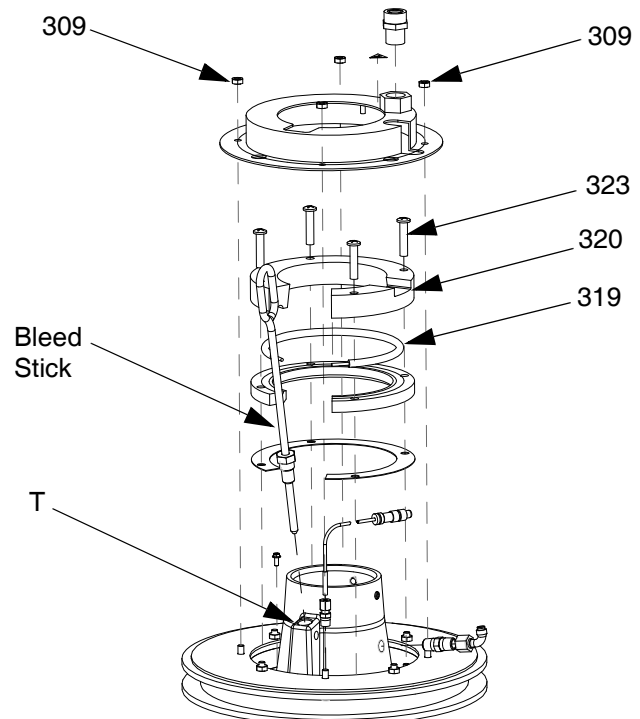
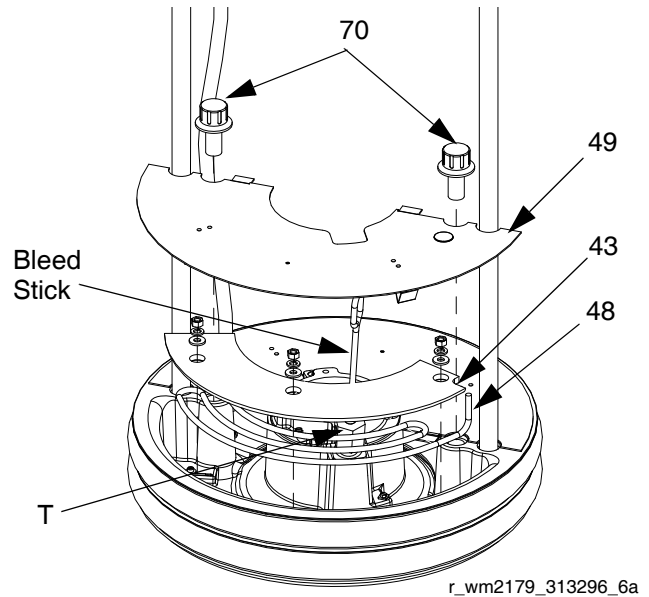



FIG. 30: Remove Platen Covers and Heaters

Electrical Enclosure

1. Turn the main disconnect on the electrical control panel door to the OFF position to disconnect power.

						
<p>Power is still connected to the power line filter (459) even after the main disconnect is open. Avoid contact with the power line filter.</p>						

2. Open door of electrical enclosure.

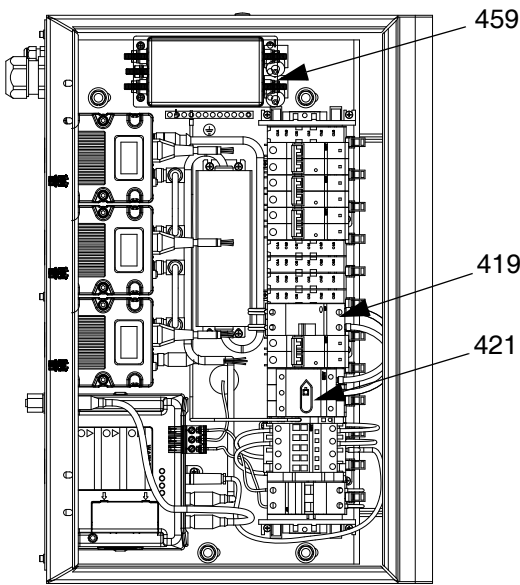



FIG. 31: Inside View of Electrical Enclosure

3. Check for damaged or loose wires. Check connections from cable track.

Check Ground Fault Circuit Interrupter

1. With electrical enclosure door still open, switch main disconnect (421) back on.

						
<p>Have a qualified electrician restore power to main disconnect while electrical enclosure door is open.</p>						

2. Press Test button on ground fault circuit interrupter (419). The blue switch should flip to the middle or opposite side.

NOTE: Do not perform this test while the system is in operation.

3. Press blue switch back into place to reset breaker.

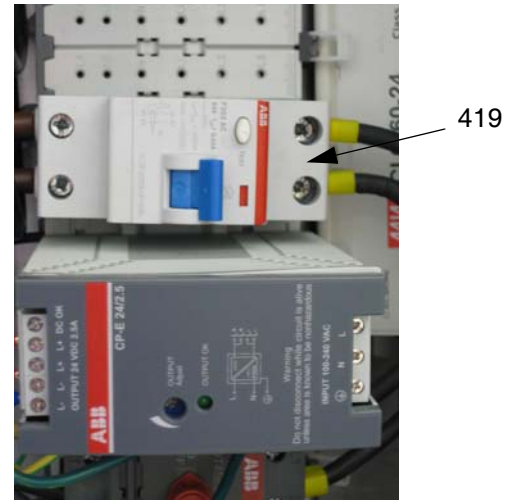

FIG. 32: Ground Fault Circuit Interrupter

4. Switch main disconnect off.

Pump Heaters

1. Turn the main disconnect on the electrical control panel door to the OFF position to disconnect power.
2. Remove four screws (80 or 257) from back pump shroud (52 or 234).

D200 Shown

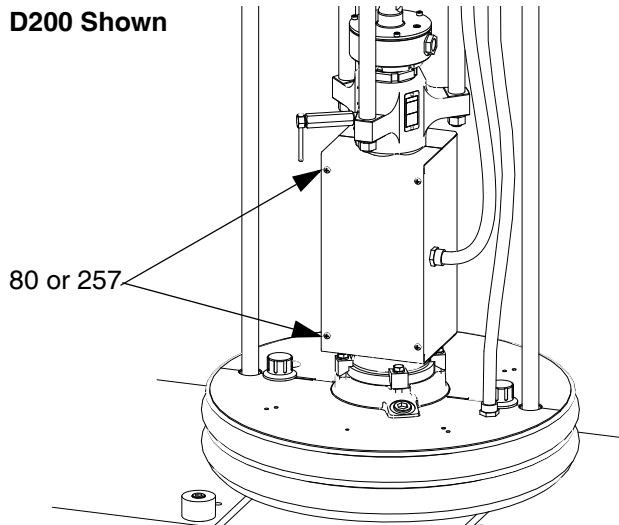

FIG. 33: Remove Pump Shroud

3. Remove pump heater front shroud (51 or 233).

4. Check for damaged wires and connections.
5. Ensure heaters (44 or 227) are secure so they cannot rotate on pump.

D200 Shown

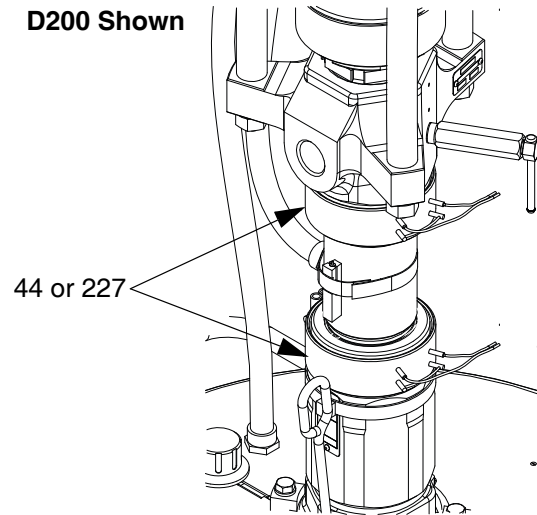

FIG. 34: Pump Heaters

Alarms

Warm Melt alarms alert you to a problem and help prevent system shutdown or application errors. If an alarm occurs, operation may stop and the following occurs.

- Light tower indication changes (if equipped)
- Status bar on the display shows the alarm description

Diagnose Alarms

See **Alarm Codes and Troubleshooting**, page 37, for causes and solutions to each alarm code.

Clear Alarms

Alarms are cleared by the solution(s) listed in the following table or from the screen in which they appear. Refer to **Alarm Codes and Troubleshooting**, page 37, for details.

Alarm Codes and Troubleshooting

Alarm Code	Alarm Problem	Cause	Solution	Clear Alarm
Fluid Control Module				
CB1X	A - Communication Error - Ram A Not Found	Ram cannot communicate with FCM A.	Verify that power is supplied.	Alarm automatically cleared by solution.
			Check that CAN cables are connected.	
			Verify that selector switch is set correctly.	
			Replace FCM A.	
CB2X	B - Communication Error - Ram B Not Found	Ram cannot communicate with FCM B.	Verify that power is supplied.	Alarm automatically cleared by solution.
			Check that CAN cables are connected.	
			Verify that selector switch is set correctly.	
			Replace FCM B	
B61X	Crossover Error (Ram A)	Inactive ram has a Not Primed alarm.	Set inactive ram to Prime mode to automatically clear alarm.	Cleared from Ram Alarm screen. See Appendix A - User Interface Display , page 93.
B62X	Crossover Error (Ram B)	There is a Runaway alarm	Correct runaway condition and clear alarm on Status screen 1.	
		There is a Drum Empty alarm.	Replace empty drum with full drum to clear.	

Alarm Code	Alarm Problem	Cause	Solution	Clear Alarm
Fluid Control Module (continued)				
DA1X DA2X	Pump Runaway A Pump Runaway B	Pump is running faster than set runaway limit due to: <ul style="list-style-type: none"> Increased air pressure. Increased fluid output. Exhausted fluid supply. Open fitting, hose, drain, or bleed valve. 	Correct runaway condition and clear alarm.	Cleared from Ram Alarm screen. See Appendix A - User Interface Display , page 93.
L11X L12X	A - Drum Empty B - Drum Empty	Drum empty sensor has been activated.	Replace empty drum with full drum to clear.	Alarm automatically cleared by solution.
DB1X DB2X	A - Not Primed B - Not Primed	The pump is not primed.	Set ram to Prime mode to automatically clear alarm, or manually clear alarm from Ram Alarm screen.	Cleared from Ram Alarm screen or Ram Operation screen. See Appendix A - User Interface Display , page 93.
WJ1X WJ2X	A - Air Solenoid Disconnected B - Air Solenoid Disconnected	Solenoid unplugged. Damaged solenoid / wires.	Check that solenoid cable is connected. Inspect solenoid wires for damage.	Alarm automatically cleared by solution. Alarm automatically cleared by solution.
DK1X DK2X	A - Air Motor Sensor Error B - Air Motor Sensor Error	System has seen multiple up strokes without a down stroke, or multiple down strokes without an up stroke. Damaged or disconnected air motor sensors.	See air motor manual. Check that air motor sensors are connected. Inspect air motor sensor harness for damage.	Cleared from Ram Alarm screen. See Appendix A - User Interface Display , page 93.
L21X L22X	A - Drum Low Deviation B - Drum Low Deviation	Drum low sensor has been activated.	Replace empty drum with full drum to clear.	Deviation automatically cleared by solution.
WK1X WK2X	A - Fluid Solenoid Disconnected Deviation B - Fluid Solenoid Disconnected Deviation	Solenoid unplugged. Damaged solenoid wires.	Check that solenoid cable is connected. Inspect solenoid cable for damage.	Deviation automatically cleared by solution.
ML1X ML2X	A - Rebuild Platen Seals B - Rebuild Platen Seals	Counter has reached programmed platen maintenance interval.	Perform platen maintenance; see Supply Systems Repair-Parts manual.	Cleared from Maintenance screen. See Appendix A - User Interface Display , page 93.
MA1X MA2X	A - Rebuild Pump B - Rebuild Pump	Counter has reached programmed pump maintenance interval.	Perform pump maintenance. See Check-Mate Displacement Pump manual.	Cleared from Maintenance screen. See Appendix A - User Interface Display , page 93.

Alarm Code	Alarm Problem	Cause	Solution	Clear Alarm
Fluid Control Module (continued)				
DD1X	A - Pump Diving	Pump leak.	Worn valve or packings. See Check-Mate Displacement Pump manual.	Cleared from Ram Alarm screen. See Appendix A - User Interface Display , page 93.
DD2X	B - Pump Diving	Ram air pressure set too low.	Increase air pressure to ram until diving stops.	
		Material flow rate exceeds ability of ram to feed pump.	Decrease pump air pressure to slow cycle rate. Decrease pressure until diving stops.	
Temperature Control Modules <i>The last digit in the temperature control module alarm codes identify the heat zone.</i>				
T3A1 T3A2 T3A3 T3A4 T3A5 T3A6 T3A7 T3A8 T3A9 T3A10 T3A11 T3A12	Alarm Above Setpoint Deviation Above Setpoint	RTD on wrong module. Shorted module.	Verify RTD wire and heater power cord is attached to correct heat module. Replace module.	Cleared from Heat Run screen. See Heat Run Screen , page 101.
T2A1 T2A2 T2A3 T2A4 T2A5 T2A6 T2A7 T2A8 T2A9 T2A10 T2A11 T2A12	Deviation Below Setpoint	Tripped circuit breaker. Low power. Cable unplugged/loose wire. Circuit breaker not set for L2 and L3. Bad heaters. GFCI has been tripped. Customer supplied main circuit breaker tripped.	Visually check circuit breaker for a tripped condition. Measure voltage across input terminals on power line filter. Voltage should measure between 190 and 250 Vac. Check for loose or disconnected wires and plugs. Visually check circuit breaker for proper setting of L2 and L3. Measure resistance of heater. Visually check GFCI for a tripped condition. Measure voltage across the disconnect switch. Voltage should measure between 190 and 275 Vac.	

Alarm Code	Alarm Problem	Cause	Solution	Clear Alarm
Temperature Control Modules (continued)				
T6A1 T6A2 T6A3 T6A4 T6A5 T6A6 T6A7 T6A8 T6A9 T6A10 T6A11 T6A12	No Temp Rise	Tripped circuit breaker.	Visually check circuit breaker for a tripped condition.	Cleared from Heat Run screen. See Heat Run Screen , page 101.
		Low power.	Measure voltage across input terminals on power line filter. Voltage should measure between 190 and 250 Vac	
		Cable unplugged/loose wire.	Check for loose or disconnected wires and plugs.	
		Circuit breaker not set for L2 and L3.	Visually check circuit breaker for proper setting of L2 and L3.	
		Bad heater(s).	Measure resistance of heater(s).	
		GFCI has been tripped.	Visually check GFCI for a tripped condition.	
		Customer supplied main circuit breaker tripped.	Measure voltage across the disconnect switch. Voltage should measure between 190 and 275 Vac.	
A4A1 A4A2 A4A3 A4A4 A4A5 A4A6 A4A7 A4A8 A4A9 A4A10 A4A11 A4A12	Over current	Bad heaters.	Measure resistance of heater.	
		Wrong zone type.	Ensure zone is set for type of hardware connected to it.	
		High voltage.	Measure voltage across the disconnect switch. Voltage should measure between 190 and 275 Vac.	
		Shorted module.	If temperature rises for a zone that has been disabled, replace heat module.	

Alarm Code	Alarm Problem	Cause	Solution	Clear Alarm
Temperature Control Modules (continued)				
A1A1 A1A2 A1A3 A1A4 A1A5 A1A6 A1A7 A1A8 A1A9 A1A10 A1A11 A1A12	Undercurrent	Tripped circuit breaker.	Visually check circuit breaker for a tripped condition.	Cleared from Heat Run screen. See Heat Run Screen , page 101.
		Over temperature protection is activated.	Allow zone to cool down.	
		Low power.	Measure voltage across input terminals on power line filter. Voltage should measure between 190 and 250 Vac.	
		Cable unplugged/loose wire.	Check for loose or disconnected wires and plugs.	
		Circuit breaker not set for L2 and L3.	Visually check circuit breaker for proper setting of L2 and L3.	
		Bad heaters.	Measure resistance of heater.	
		GFCI has been tripped.	Visually check GFCI for a tripped condition.	
		Customer supplied main circuit breaker tripped.	Measure voltage across the disconnect switch. Voltage should measure between 190 and 250 Vac.	
		Wrong zone type.	Ensure zone is set for type of hardware connected to it.	
A7A1 A7A2 A7A3 A7A4 A7A5 A7A6 A7A7 A7A8 A7A9 A7A10 A7A11 A7A12	Unexpected Current	Shorted module.	If temperature rises for a zone that has been disabled, replace heat module.	Cleared from Heat Run screen. See Heat Run Screen , page 101.
T6A1 T6A2 T6A3 T6A4 T6A5 T6A6 T6A7 T6A8 T6A9 T6A10 T6A11 T6A12	Invalid RTD Reading	Bad RTD.	Measure resistance of RTD and verify it is within valid range.	Cleared from Heat Run screen. See Heat Run Screen , page 101.
		Bad RTD connection/loose wire.	Check for loose or disconnected wires and plugs.	
		Component not plugged in.	Ensure a component is plugged into zone reporting error. If nothing is plugged in, disable zone.	

Alarms

Alarm Code	Alarm Problem	Cause	Solution	Clear Alarm
T4C1 T4C2 T4C3 T4C4 T4C5 T4C6 T4C7 T4C8 T4C9 T4C10 T4C11 T4C12	PCB Overtemperature	Overheated Temperature Control Module.	Turn heat zone off. Wait a few minutes. If the condition does not clear on its own, replace heater module.	Cleared from Heat Run screen. See Heat Run Screen , page 101.
V4M1 V4M2 V4M3 V4M4 V4M5 V4M6 V4M7 V4M8 V4M9 V4M10 V4M11 V4M12	High Line Voltage	Incoming line voltage is too high.	Measure voltage across disconnect switch. Voltage should measure between 190 and 250 Vac.	Cleared from Heat Run screen. See Heat Run Screen , page 101.
V1M1 V1M2 V1M3 V1M4 V1M5 V1M6 V1M7 V1M8 V1M9 V1M10 V1M11 V1M12	No Line Voltage Low Line Voltage	Tripped circuit breaker.	Visually check circuit breaker for a tripped condition.	Cleared from Heat Run screen. See Heat Run Screen , page 101.
		GFCI has been tripped.	Visually check GFCI for a tripped condition.	
		Cable unplugged/loose wire.	Check for loose or disconnected wires and plugs.	
V4I1 V4I2 V4I3 V4I4 V4I5 V4I6 V4I7 V4I8 V4I9 V4I10 V4I11 V4I12	High DC Voltage	Faulty DC power supply.	Measure that DC supply output is 24V. If not, replace supply.	Cleared from Heat Run screen. See Heat Run Screen , page 101.

Alarm Code	Alarm Problem	Cause	Solution	Clear Alarm
Temperature Control Modules (continued)				
V111 V112 V113 V114 V115 V116 V117 V118 V119 V1110 V1111 V1112	Low DC Voltage	Faulty DC power supply. Broken Temperature Control Module.	Measure that DC supply output is 24V. If not, replace supply. If DC supply is supplying 24V when disconnected from system, check which module is causing short. Check this by connecting one module at a time and then measuring for 24V.	Cleared from Heat Run screen. See Heat Run Screen , page 101.
A4C1 A4C2 A4C3 A4C4 A4C5 A4C6 A4C7 A4C8 A4C9 A4C10 A4C11 A4C12	High Contactor Current	Broken contactor.	Replace contactor.	Cleared from Heat Run screen. See Heat Run Screen , page 101.
A1C1 A1C2 A1C3 A1C4 A1C5 A1C6 A1C7 A1C8 A1C9 A1C10 A1C11 A1C12	Low Contactor Current	Broken contactor. Disconnected or loose wire. Broken Temperature Control Module.	Replace contactor. Verify cable 15W902 from High Power Temperature Control Module is connected correctly. Verify there is 24V between both wires on 15W902. If there is not 24V, replace High Power Temperature Control Module.	Cleared from Heat Run screen. See Heat Run Screen , page 101.
A7C1 A7C2 A7C3 A7C4 A7C5 A7C6 A7C7 A7C8 A7C9 A7C10 A7C11 A7C12	Unexpected Contactor Current	Broken Temperature Control Module.	Turn heat zone for platen off. If there is still 24V across wires on 15W902, replace Temperature Control Module.	Cleared from Heat Run screen. See Heat Run Screen , page 101.

Troubleshooting



NOTE: Troubleshooting covered in this manual is specific to warm melt heat functions. Refer to **Supply Systems Repair-Parts manual** and/or **Tandem Supply Systems Repair-Parts manual** for ram troubleshooting. Refer to **Check-Mate Pump Packages manual** for pump troubleshooting.

1. Follow **Pressure Relief Procedure**, page 29, before disassembling any part of the warm melt supply system.
2. Disconnect all power to the warm melt supply system before repairing.
3. Check all possible problems before disassembling any part of the warm melt supply system.

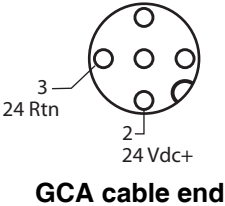
Problem	Cause	Verification	Solution
No power.	Customer supplied main circuit breaker tripped.	Measure voltage across disconnect switch; voltage should measure between 190 and 250 Vac.	Determine cause of the tripped circuit breaker. Then repair fault and reset main circuit breaker.
	GFCI has been tripped.	Visually check GFCI for a tripped condition.	Determine fault that caused GFCI to trip. Then repair fault and reset GFCI.
No graphics on screen.	No graphics are shown on display screen.	Verify green LED on bottom of display is illuminated.  <p style="text-align: center;">GCA cable end</p>	If green LED is not illuminated: <ol style="list-style-type: none"> 1. Check for DC power on the GCA cable at the display. Replace faulty cable/component. 2. Replace faulty display module. <p>If green LED is illuminated, check red LED. If red LED is illuminated, replace display module.</p>
	Backlight does not power up.	Can see display, but backlight is not illuminated when a button is pressed.	Replace display module.

Problem	Cause	Verification	Solution
No heat.	Tripped circuit breaker.	Visually check circuit breaker for a tripped condition.	Determine cause of tripped circuit breaker. Then repair fault and reset main circuit breaker.
	Low power.	Measure voltage across terminals 2T1 and 4T2 on main disconnect. Voltage should measure between 190 and 275 Vac.	<ol style="list-style-type: none"> 1. If voltage is lower than expected, use electrical schematic to locate faulty wiring or connection. 2. Have a qualified electrician service electrical components.
	Cable unplugged/loose wire.	Check for loose or disconnected wires and plugs.	Attach plug/wire.
	GFCI tripped.	Visually check GFCI for a tripped condition.	Determine fault that caused GFCI to trip. Repair fault, and reset GFCI.
	Zone not enabled.	Verify zone is enabled on Heat Run screen.	Enter Setup screen and enable correct zone.
	Incorrect temperature set point.	Verify zone has a correct temperature setting on Heat Run screen.	Enter Setup and enter correct temperature.
	Bad heater.	Measure resistance of heater.	<ol style="list-style-type: none"> 1. Unplug suspected heater zone from heater module. 2. Follow Heater Resistance Checks, page 23. 3. If resistance is outside allowable value, replace heater(s).
	Contactor not closing.	Turn on heat for zone A1 or B1 and ensure contactor closes.	<ol style="list-style-type: none"> 1. Verify cable 15W902 from the high power TCM is connected correctly. 2. Verify that there are no other error conditions that would prevent heater from starting. 3. Verify there is 24 Vdc between 2 wires on 15W902. If not, replace high power TCM. See Alarms, page 37. 4. Replace contactor.

Problem	Cause	Verification	Solution
Missing module.	Modules not on network.	Verify attached modules through Advanced Setup screens 4 and 5.	Enter Setup screen and scroll to Advanced Setup screens 4 and 5. These screens lists all components corresponding software revision number on network.
	Cable disconnected.	Verify all green LEDs are illuminated and yellow LEDs are flashing.	Reconnect/replace faulty cable.
	Module with wrong rotary switch setting.	Verify rotary switch is set correctly.	<ol style="list-style-type: none"> 1. Remove power from unit. 2. Remove access cover and visually check rotary switch setting. 3. If incorrect, set to correct setting. See Upgrade Temperature Control Module Software, page 56, and Upgrade FCM Software, page 59, for selector switch locations. 4. Replace access cover.
Heating is slow.	Heater defective.	Measure resistance of heater.	Follow Heater Resistance Checks , page 23.
	Low power.	Measure voltage across terminals 2T1 and 4T2 on main disconnect. Voltage should measure between 190 and 275 Vac.	<ol style="list-style-type: none"> 1. If voltage is lower than expected, use electrical schematic to locate faulty wiring or connection. 2. Have a qualified electrician service electrical components.
Heating over shoots.	RTD on wrong module.	Verify for given zone that temperature does not increase when zone is disabled.	Verify RTD wire or heater power cord is attached to correct heat module.
	Shorted module.		Replace module.
Does not crossover.	Alternate ram has an empty sensor activated.	Verify ram has material.	Replace empty drum.
	Alternate pump is not primed.	Verify alternate ram is ready to run.	Prime pump.
	Alternate pump has an active alarm.	See Alarm Codes and Troubleshooting , page 37.	See Alarm Codes and Troubleshooting , page 37.

Repair

--	--	--	--	--	--	--

To reduce the risk of serious injury, follow the **Pressure Relief Procedure** and the **Load Material** procedure prior to performing repair procedures.

Air Motor

Remove Air Motor

Remove junction box.

For 55 gallon platen (D200 and D200s supply systems): Remove two screws (61) securing junction box to air motor. Remove junction box and temporarily secure to platen rod.

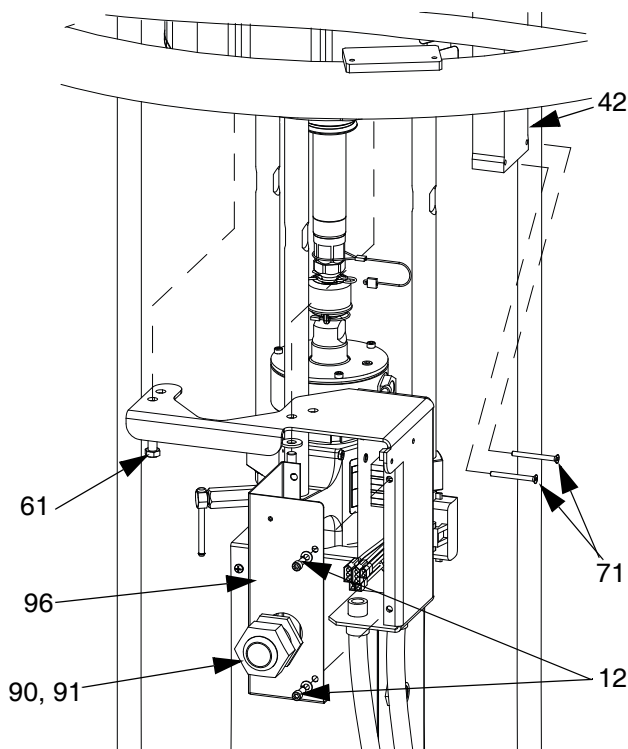

FIG. 35: Remove D200 and D200s Junction Box

For smaller platens (D60 3 in. supply systems): Remove junction box. Remove screws (278) from junction box (255), and remove cover (271). Remove junction box from bracket (258).

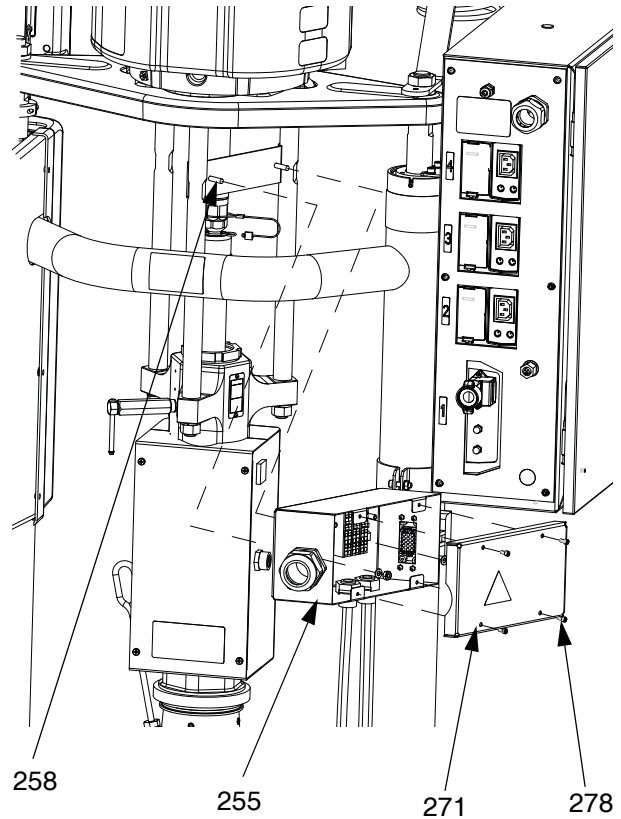

FIG. 36: Remove D60 Junction Box

3. See **Disconnect Displacement Pump** in Check-Mate Pump Packages manual.

--	--	--	--	--	--	--

To reduce the risk of serious injury or damage to equipment, make sure the main disconnect is off before continuing with this procedure.

4. See Supply System repair manual for air motor removal instructions.

Install Air Motor

1. See Supply System repair manual for air motor installation instructions.
2. Reinstall junction box.

For 55 gallon platen (D200 and D200s supply systems): Remove junction box from platen rod. Reinstall junction box to air motor using move two screws (61). See FIG. 35.

For smaller platens (D60 3 in. supply systems): Reinstall junction box (255) onto bracket (258). Use screws (278) to attach cover (271). See FIG. 36.

Displacement Pump

Remove Displacement Pump



This procedure must be done while the system is still warm. The material and equipment may still be hot.

Refer to your Check-Mate Displacement Pump manual to repair the displacement pump.

If the air motor does not require servicing, leave it attached to its mounting. If the air motor does need to be removed, see **Remove Air Motor**, page 47.

D200 and D200s Supply Systems

1. Disconnect air hose and ground wire from air motor.
2. See **Disconnect Displacement Pump** in Check-Mate Pump Packages manual.
3. Follow steps 1- 4 of **Replace Platen Heaters and Sensor** section, page 52, to remove pump heater

shrouds (51, 52), pump heaters (44), and RTD sensor (46).

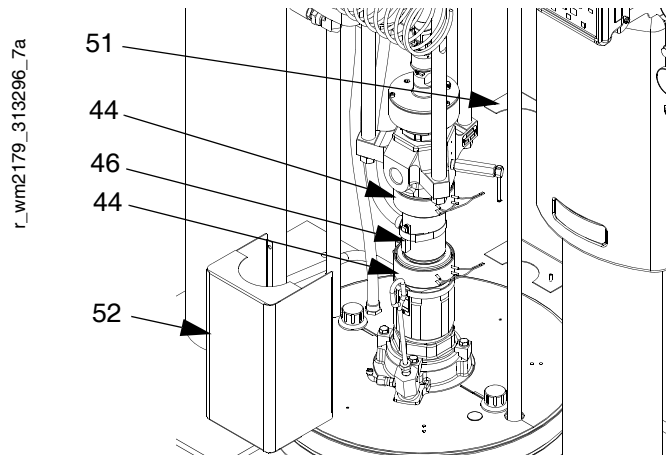

FIG. 37: D200 and D200s Pump Heater Shrouds

4. Raise air motor. Loosen nut (HB) under ram bar and thread it down the threaded rod (HC) to the lift ring adapter (HD) holding the motor. Use wrench on nut (HA) on top of ram bar to raise air motor.

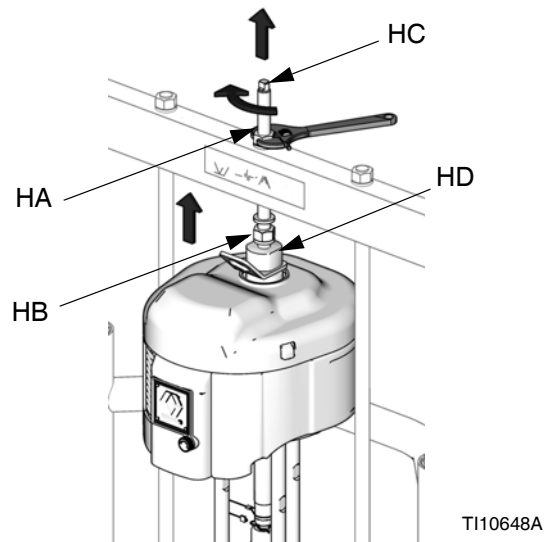

FIG. 38: Raise Air Motor

5. See **Disconnect Pump from Platen**, page 50, to disconnect the displacement pump from the platen.
6. Use two people to carefully lift out the displacement pump. Service displacement pump as needed. See Check-Mate Displacement Pump manual for instructions.

D60 Supply System

1. Disconnect air hose and ground wire from air motor.
2. See **Disconnect Displacement Pump** in Check-Mate Pump Packages manual.
3. Follow steps 1- 4 of **Replace Platen Heaters and Sensor** section, page 52, to remove pump heater shrouds (233, 234), pump heaters (227), and RTD sensor (229).

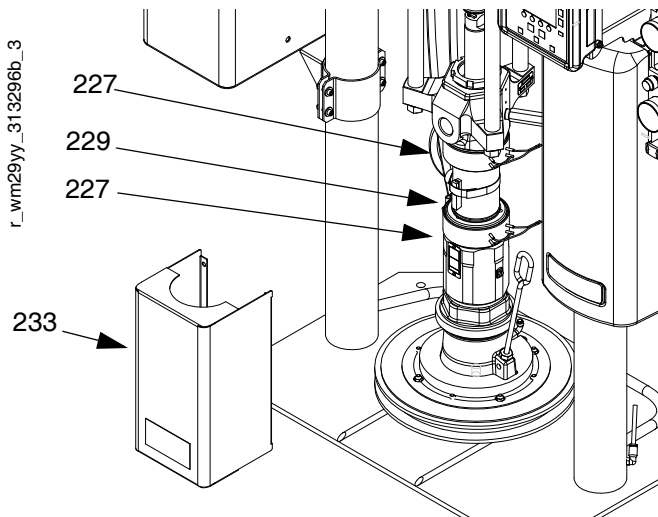

FIG. 39: D60 Pump Heater Shrouds

4. See to **Disconnect Pump from Platen** on page 50 to disconnect displacement pump from platen.
5. Raise ram assembly to lift air motor away from displacement pump.
6. Remove displacement pump, and service as needed. See Check-Mate Displacement Pump manual.

Install Displacement Pump

D200 and D200s Supply Systems

1. Install displacement pump on platen. See **Connect Pump to Platen**, page 51.
2. Lower air motor. Use wrench on nut (EA) to lower air motor.
3. Reinstall pump heater shrouds (51, 52). Secure with screws (80).
4. See **Reconnect Displacement Pump** in Check-Mate Pump Packages manual.
5. Reconnect air hose and ground wire to air motor.

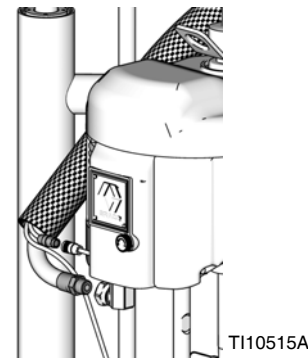

FIG. 40: Reconnect Air Hose and Ground Wire

D60 Supply System

1. Raise ram to install displacement pump to platen.
2. Connect displacement pump to platen. See **Connect Pump to Platen**, page 51.
3. Reinstall pump heater shrouds (233, 234). Secure with screws (257).
4. See **Reconnect Displacement Pump** in Check-Mate Pump Packages manual.
5. Reconnect air hose and ground wire to air motor.

Disconnect Pump from Platen



The pump is mounted to the platens by mounting Kit 255392.

55 Gallon Platen

1. Disconnect displacement pump from air motor. See Check-Mate Pump Packages manual.
2. Raise air motor. See **Remove Displacement Pump**, page 48.
3. Remove four screws (103a) and four clamps (103b).

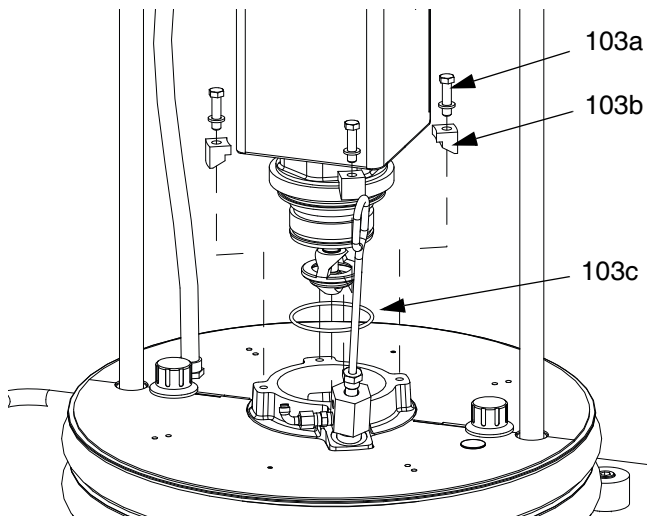

FIG. 41: 55 Gallon Mounting Kit

4. Use two people to carefully lift pump from platen.
5. Inspect o-ring (103c) for damage. Replace o-ring if necessary.

20, 30, and 60 Liter Platens

1. Disconnect displacement pump from air motor. See Check-Mate Pump Packages manual.
2. Raise air motor. See **Remove Displacement Pump**, page 48.
3. Remove screws (308) from platen.

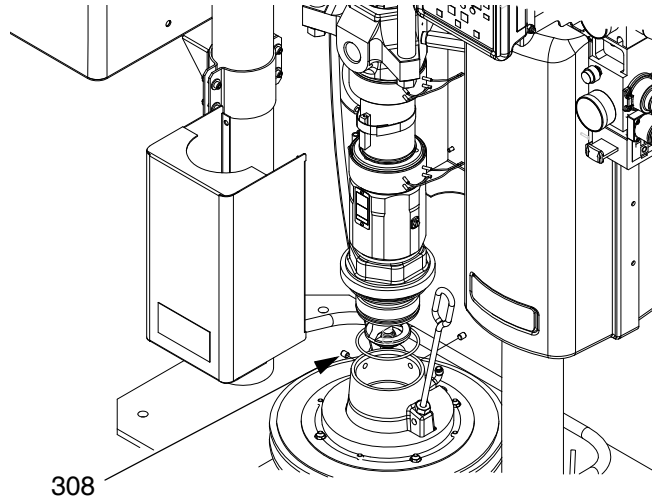

FIG. 42: 20, 30, 60 Liter Mounting

4. Use two people to carefully lift pump from platen. If using a pump with an intake adapter, remove screws, adapter, and o-rings from pump inlet.
5. Inspect o-ring for damage. Replace o-ring if necessary.

Connect Pump to Platen



55 Gallon Platen

1. Use two people to set pump onto platen.
2. Secure pump to platen with screws (103a) and clamps (103b). See FIG. 41.
3. Lower air motor.
4. See **Reconnect Displacement Pump** in Check-Mate Pump Packages manual.

20, 30, and 60 Liter Platen

NOTE: Before installing a 20, 30, or 60 liter platen to a pump with an intake adapter, install adapter and o-ring.

1. Place o-ring on pump intake. See FIG. 42.
2. Use two people to set pump onto platen.
3. Secure pump to platen with screws (308).
4. Lower air motor.
5. See **Reconnect Displacement Pump** in Check-Mate Pump Packages manual.

Replace Pump Heaters



1. Turn off main disconnect.
2. Remove screws (80 or 257) from back pump heater shroud (52 or 234).

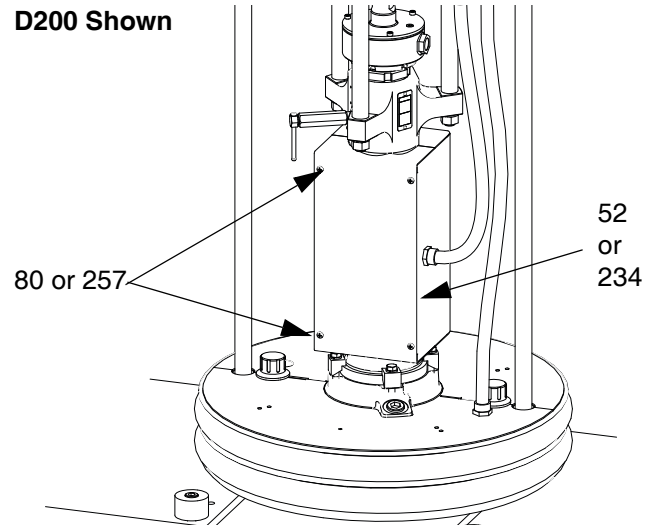

FIG. 43: Remove Pump Shroud

3. Remove ground wires.
4. Remove pump heater front shroud (51 or 233).

5. Remove pump heater bands (44 or 227):
 - a. Remove screws from both pump heaters.
 - b. Pry heater bands apart and remove from pump.
 - c. Disconnect wires from heater bands. Inspect wires for damage, and replace with new wires (included with pump heaters) if necessary. See **Electrical Schematics**, page 61.
 - d. Remove RTD sensor (46 or 229). Loosen screw on sensor support (45 or 228) and slide RTD out.

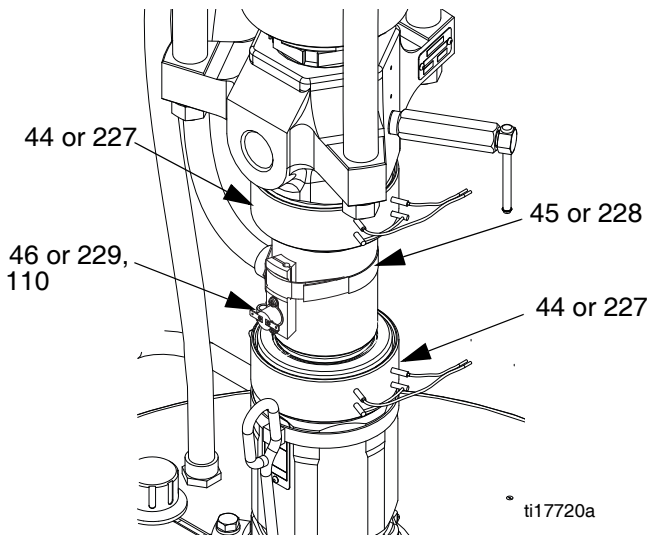

FIG. 44: Remove Pump Heaters

6. Install new pump heater bands and secure with screws.
- NOTE: To ease pump heater band installation, first install heater bands on middle of displacement pump. Then slide heater band up or down into correct location.**
7. Reinstall RTD sensor and tighten screw on sensor support.
- NOTE: Ensure RTD is flush to pump before tightening screw.**
8. Reinstall pump heater front shroud.
 9. Reinstall ground wires.
 10. Reinstall back pump heater shroud, and secure with screws.

Replace Platen Heaters and Sensor



55 Gallon Platen Heater and Sensor

1. Turn off main disconnect.
2. Remove both platen cover fasteners (70).
3. Remove both platen covers (49) and ground wire from platen.

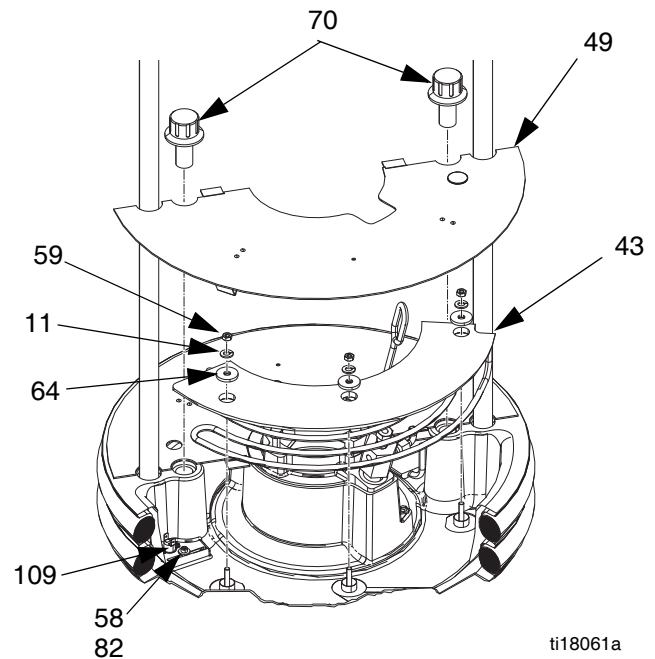
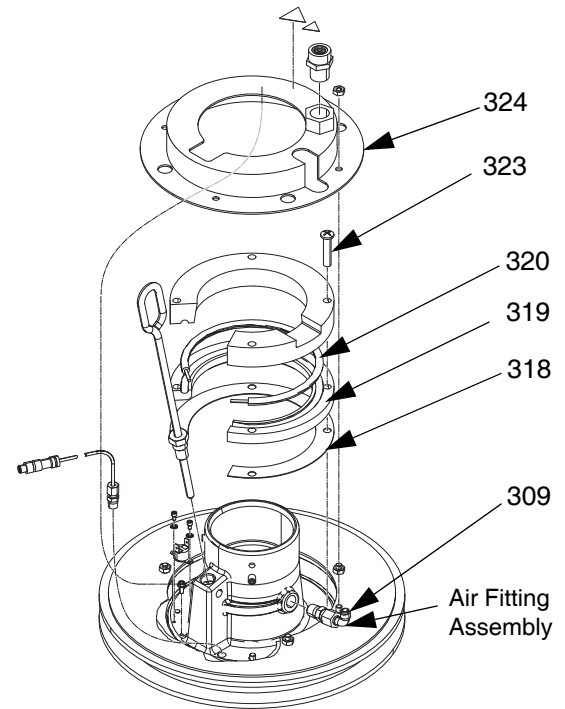

FIG. 45: Replace Platen Heaters and RTD Sensor

4. Remove platen heater blocks (43).
 - a. Use a hex wrench to remove three nuts (59) and washers (11, 64) from each heater block.
 - b. Remove screws (12) from junction box cover (96). Loosen strain relief nut (91), and remove junction box cover.
 - c. Disconnect four platen heater wires (labeled A and B) and RTD sensor connector in the terminal box. See **Electrical Schematics**, page 61.

- d. Remove screws (58) and washers (82).
Remove platen heater blocks (43) and RTD sensor (46).
5. Install new platen heaters and RTD sensor. Secure RTD sensor with screw and washer. Secure platen heater blocks with nuts and washers.
6. Label platen heater wires A and B as shown on page 64. Reroute platen heater wires and platen RTD sensor through the conduit to the junction box. Reconnect the four wires to the appropriate terminal block A and B. Reconnect the platen RTD sensor.
7. Reinstall junction box cover. Secure with screws and tighten strain relief nut.
8. Reconnect ground wire, and install platen covers. Secure platen covers with fasteners. Torque platen cover fasteners to 60 in-lbs +/- 10 in-lbs (6.8 +/- 1.1 N•m)
9. Reconnect displacement pump using screws and clamps.



ti17717b

20, 30, and 60 Liter Platen Heater

1. Disconnect pump from platen.
2. Remove platen heater block (320).
 - a. Remove screws (278) from junction box cover (271), and remove junction box cover. See page 86.
 - b. Remove strain relief nut (265) from junction box to allow space for wires. See page 86.
 - c. Remove air fitting assembly from platen.
 - d. Remove nuts (309) from the heat shield guard (324).
 - e. Remove screws (323) from upper heater plate (320). Remove upper heater plate and ground wire.

Fig. 46: Replace Platen Heaters

3. Remove platen heater (319).
 - a. Disconnect two platen heater wires (labeled A and B) in the terminal box. See **D60 Junction Box Schematic**, page 71.
 - b. Remove platen and heater (319).
4. Install new platen heater (319) to lower heater plate (318). Install upper heater plate (320). Reconnect ground wire, and secure with screws.
5. Label platen heater wires A and B as shown on page page 70. Reroute platen heater wires through the conduit to the junction box. Reconnect the two wires to the appropriate terminal block A and B.
6. Reinstall heat shield guard. Secure with nuts. Torque nuts to 45 +/- 5 in-lbs (5.1 +/- 0.6 N•m).
7. Reconnect displacement pump using screws and clamps.
8. Reinstall junction box cover and strain relief nut. Secure cover with screws.

Replace Platen Wipers

Refer to Supply Systems Repair-Parts manual for instructions.

Replace Ram Piston Rod Seals



1. Support electrical enclosure (13 or 14) using a loop and a hoist.
2. Remove screws from bracket (50 or 232) connecting electrical enclosure (13 or 14) to ram piston rod and cable track (42, if applicable).

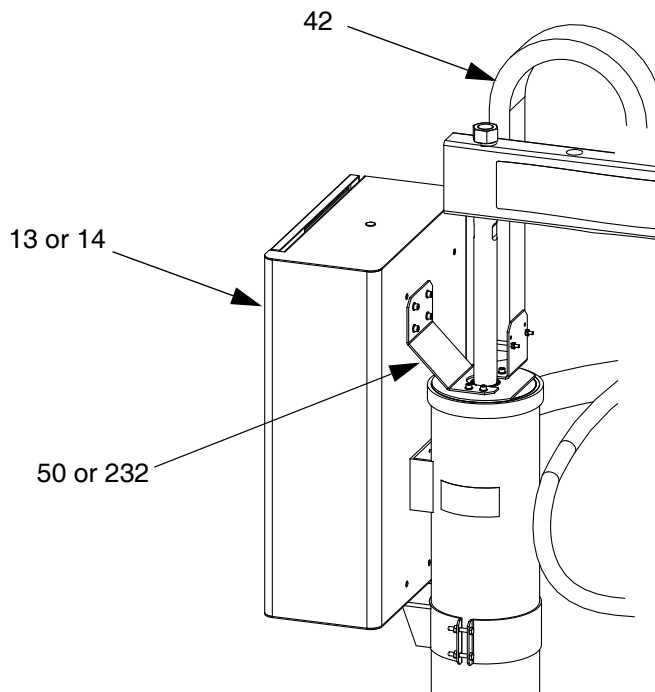

FIG. 47: Replace Rod Seals



3. *For 55 gallon platen (D200 and D200s supply systems):* Gently move cable track (42) and bracket (50) to side.

For smaller platens (D60 supply systems): Remove bracket (232).

4. See Supply Systems Repair-Parts manual for replacement instructions.
5. Follow steps in reverse order to reinstall bracket, cable track (if applicable), and the electrical enclosure.

Electrical Enclosure

Prior to repairing any component of the electrical enclosure (13 or 14), turn the main disconnect on the electrical control panel door to the OFF position to disconnect power.

						
<p>Power is still connected to the power line filter (459) even after the main disconnect is open. Avoid contact with the power line filter.</p>						

Replace Low Power Temperature Control Module(s)

- Open enclosure door (402). Disconnect the following cables from low power TCM (408):
 - incoming power supply cable (430)
 - outbound power supply cable (see FIG. 49)
 - RTD cable

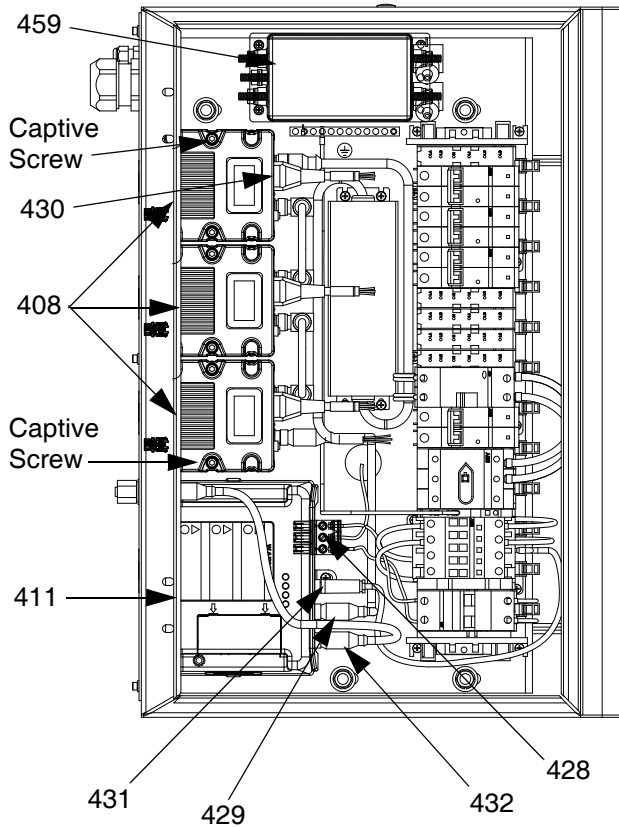

FIG. 48: Internal View of Electrical Enclosure

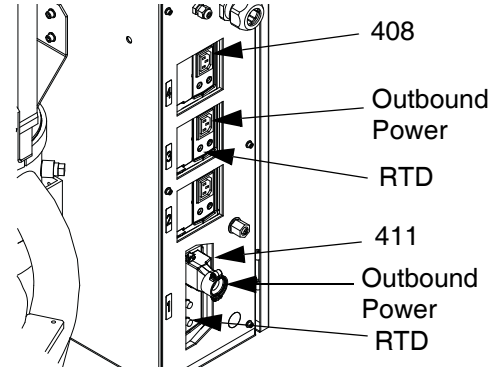

FIG. 49: Back View of Electrical Enclosure

- Loosen both captive screws (409) holding low power TCM (408) to base (407); remove low power TCM. See FIG. 48.
- Follow steps in reverse order to install new low power TCM.
- Upload the correct TCM software for the system. See **Upgrade Temperature Control Module Software**, page 56, for instructions.

Replace Base

1. Remove low power TCM. See **Replace Low Power Temperature Control Module(s)**.
2. Disconnect two CAN cables from base (407).
3. Remove four screws (409) and ground screw (410) from base.
4. Replace with new base and secure with screws.
5. Reconnect two CAN cables to base.
6. Set selector switch to:

- “0” for TCM labeled “2” on Ram A
- “1” for TCM labeled “3” on Ram A
- “2” for TCM labeled “4” on Ram A
- “5” for TCM labeled “2” on Ram B
- “6” for TCM labeled “3” on Ram B
- “7” for TCM labeled “4” on Ram B

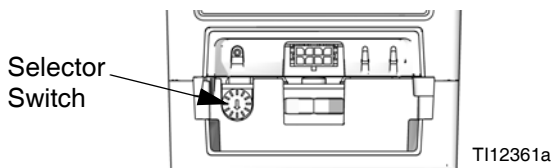

FIG. 50: Set Selector Switch

7. Reinstall low power TCM. See **Replace Low Power Temperature Control Module(s)**.

NOTE: Reuse brackets (412, 413) to install new high power TCM.

Replace High Power Temperature Control Module

1. Open enclosure door (402). Disconnect outbound power supply and RTD cables from high power TCM (411). See FIG. 49.
2. Remove electrical enclosure side panel (436). See **Electrical Enclosure Parts** on page 90.
3. Disconnect all four incoming cables (432, 428, 429, 431) from high power TCM. See FIG. 48.
4. Remove both screws (415) that secure brackets (412, 413) of high power TCM to electrical enclosure. Remove high power TCM. See **Electrical Enclosure Parts** on page 90.
5. Follow steps in reverse order to install new high power TCM.

NOTE: Reuse brackets (412, 413) to install new high power TCM.

6. Upload the correct TCM software from kit 16C027. See **Upgrade Temperature Control Module Software**, page 56, for instructions.
7. Remove cover of new high power TCM and set selector switch to “0” for Ram A or “1” for Ram B.

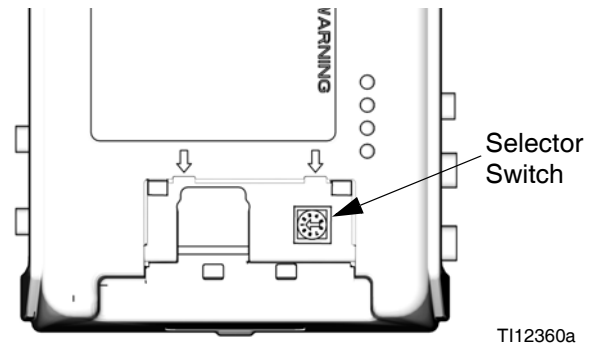

FIG. 51: Set Selector Switch

Upgrade Temperature Control Module Software

NOTE: Order kit 16C027 for an upgrade token. See Graco Control Architecture™ Module Programming manual for instructions.

Replace Circuit Breakers

1. Open enclosure door (402). Disconnect wires from circuit breaker (417, 419).
2. Push in circuit breaker tab and pull out breaker.

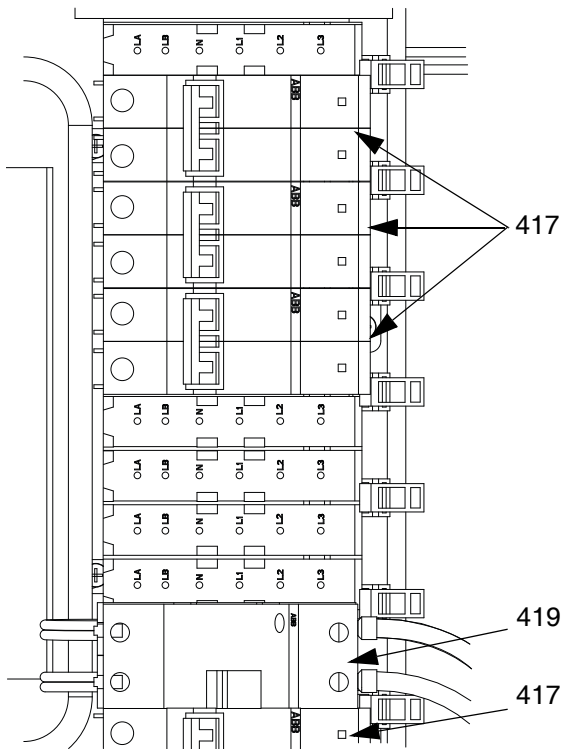

FIG. 52: Circuit Breakers

3. Replace with new circuit breaker. Use tabs on bottom of breaker to select L2 and L3.
4. Snap new circuit breaker into place and reconnect wires.

Replace Electrical Enclosure

1. Ensure power to electrical enclosure is disconnected.
2. Disconnect heater and RTD cables from each TCM.
3. Remove plug and use lift ring (not included) at top of electrical enclosure (13 or 14).

4. Remove screws (12 or 202) and washers (11 or 201) from bottom bracket (39 or 222) and side bracket (50 or 232) of enclosure.

D200 Shown

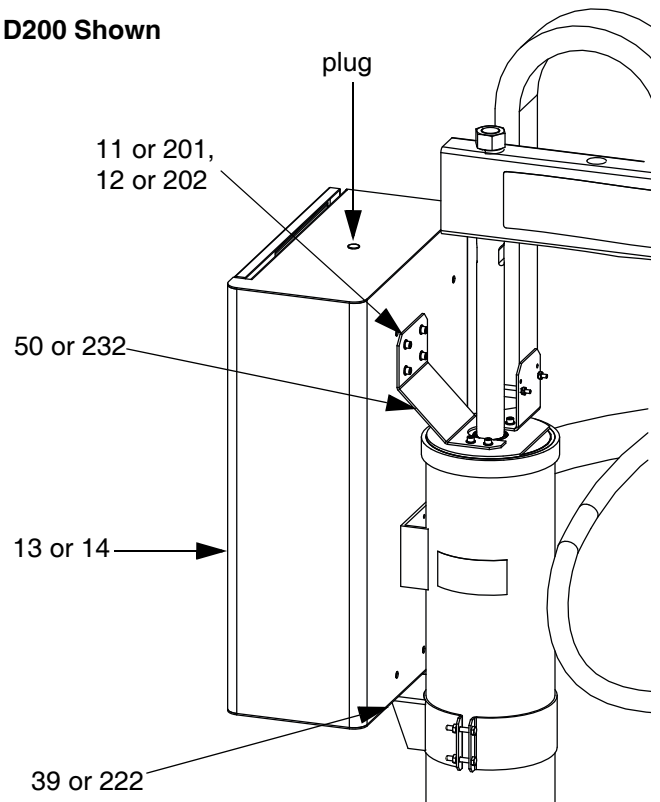

FIG. 53: Replace Electrical Enclosure

5. Lift enclosure off and replace with new enclosure.
6. Secure new electrical enclosure to bottom and side brackets with screws and washers.
7. Reconnect heater and RTD cables to each TCM.
8. Reconnect power to power line filter.

<p>Have a qualified electrician reinstall main incoming power to system and electrical enclosure.</p>							

Display/User Interface

Upgrade Display Software

NOTICE

To avoid damaging circuit board, wear a grounding strap.

NOTE: Order kit 16C027 for an upgrade token. See Graco Control Architecture™ Module Programming manual for instructions.

Replace Display

NOTE: Order Kit 24F493 for replacement. Software token 16C027 is required to install software before use.

NOTICE

To avoid damaging circuit board, wear a grounding strap.

1. Disconnect power.
2. Pull display (20) out of bracket (22) clips to remove it.
3. Disconnect CAN cable(s) from display (20).
4. Replace with new display. Reconnect CAN cable(s).
5. Load the correct display software for the system. Follow the steps in **Upgrade Display Software** on page 58.

NOTE: Token is not included with display and must be ordered separately.

Replace Fluid Control Module



1. Disconnect power to system.
2. Remove front shroud (16 or 204) and back shroud (17 or 205).

D200 Shown

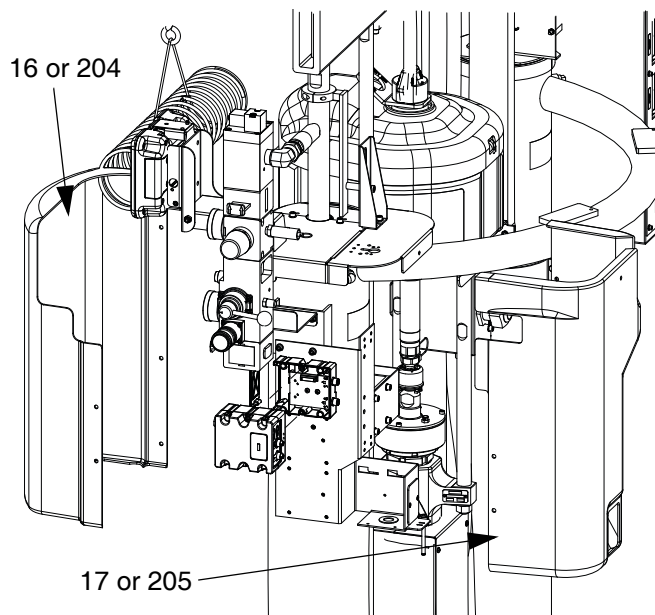

FIG. 54: Remove Shrouds

3. Disconnect all cables from FCM (36 or 220).
4. Remove access door (41 or 224).
5. Loosen both captive screws from FCM and pull FCM off base (33 or 219).

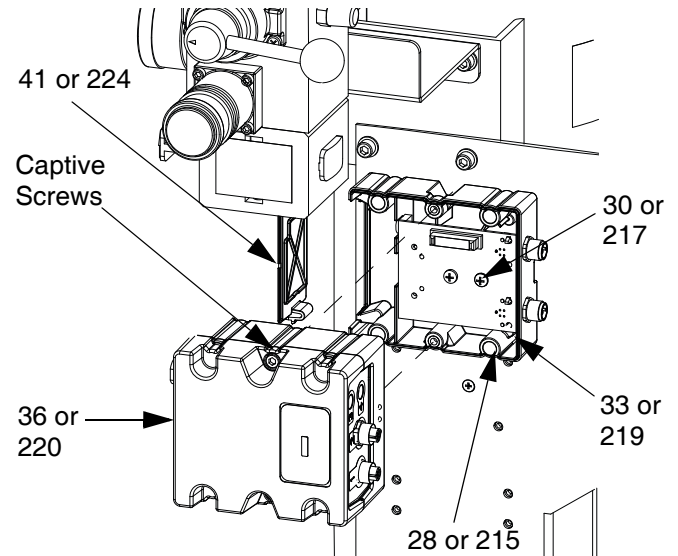

FIG. 55: Remove FCM

6. Replace with new FCM, and secure with screws.
7. Reconnect cables to FCM.
8. Load the correct FCM software for the system. Follow the steps in **Upgrade FCM Software** on page 59.

Replace Base

1. Disconnect power to system.
2. Remove FCM (36 or 220). See **Replace Fluid Control Module**.
3. Disconnect CAN cable(s) from FCM (36 or 220).
4. Remove screws (28 or 215) and ground screw (30 or 217) from base (33 or 219). See FIG. 55.
5. Replace with new base, and secure with screws.
6. Reconnect CAN cable(s).
7. Set selector switch to "A" for Ram A or "B" for Ram B. See FIG. 55.
8. Reinstall FCM. See **Replace Fluid Control Module**.

Upgrade FCM Software

NOTE: Order kit 16C027 for an upgrade token. See **Graco Control Architecture™ Module Programming manual for instructions**.

Replace Cable Track

D200 and D200S Supply Systems Only



NOTE: Order Kit 257163 for replacement.

1. Disconnect power to system.
2. Disconnect all 10 cables from back of electrical enclosure (13 or 14).

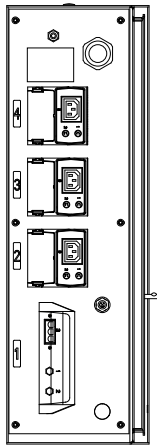

FIG. 56: Back View of Electrical Enclosure

3. Remove screws (71) from bracket (50) that connect cable track (42) to electrical enclosure (13 or 14) and ram.

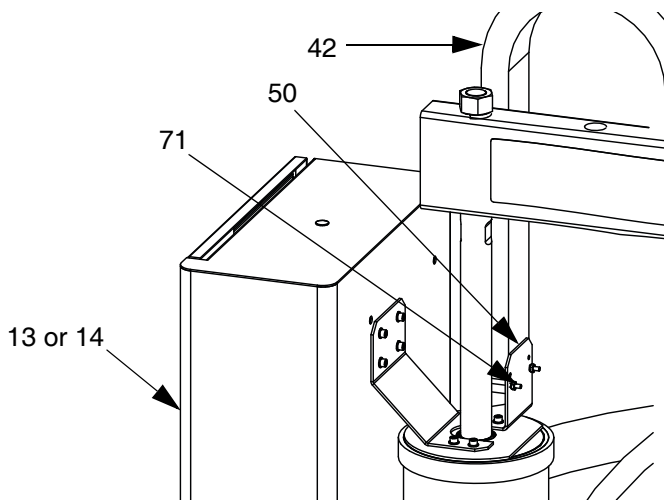

FIG. 57: Cable Track Bracket

4. Remove screws (12) from junction box cover (96) and junction box (78).
5. Loosen strain relief nut (90), and remove junction box cover.
6. Disconnect all wires in junction box. Pull wires out of strain relief.
7. Remove mounting screws (71), washer (72), and nut (73) securing cable track assembly (42) to junction box.

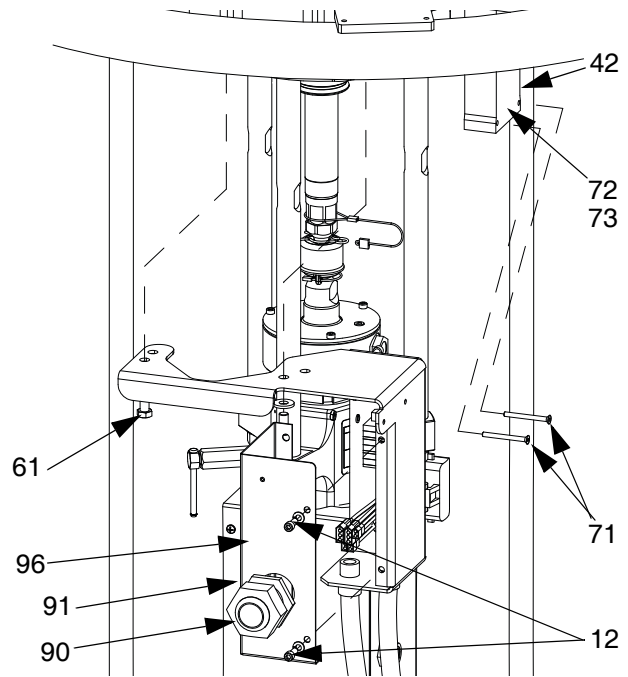

FIG. 58: Junction Box

8. Lift out cable track assembly and cables.
9. Replace with new cable track kit. Secure new cable track to junction box using mounting screws.
10. Run wires through strain relief and reconnect all wires in junction box. See **D200 Junction Box Schematic**, page 65.
11. Reinstall strain relief nut and junction box cover. Secure junction box using screws.
12. Reattach cable track to bracket. Use screws to secure bracket holding cable track to electrical enclosure and ram.
13. Reconnect all 10 cables to back of electrical enclosure.
14. Reconnect power to system.

Electrical Schematics

D200 Single Ram Schematic

Warm Melt
Standard Ram

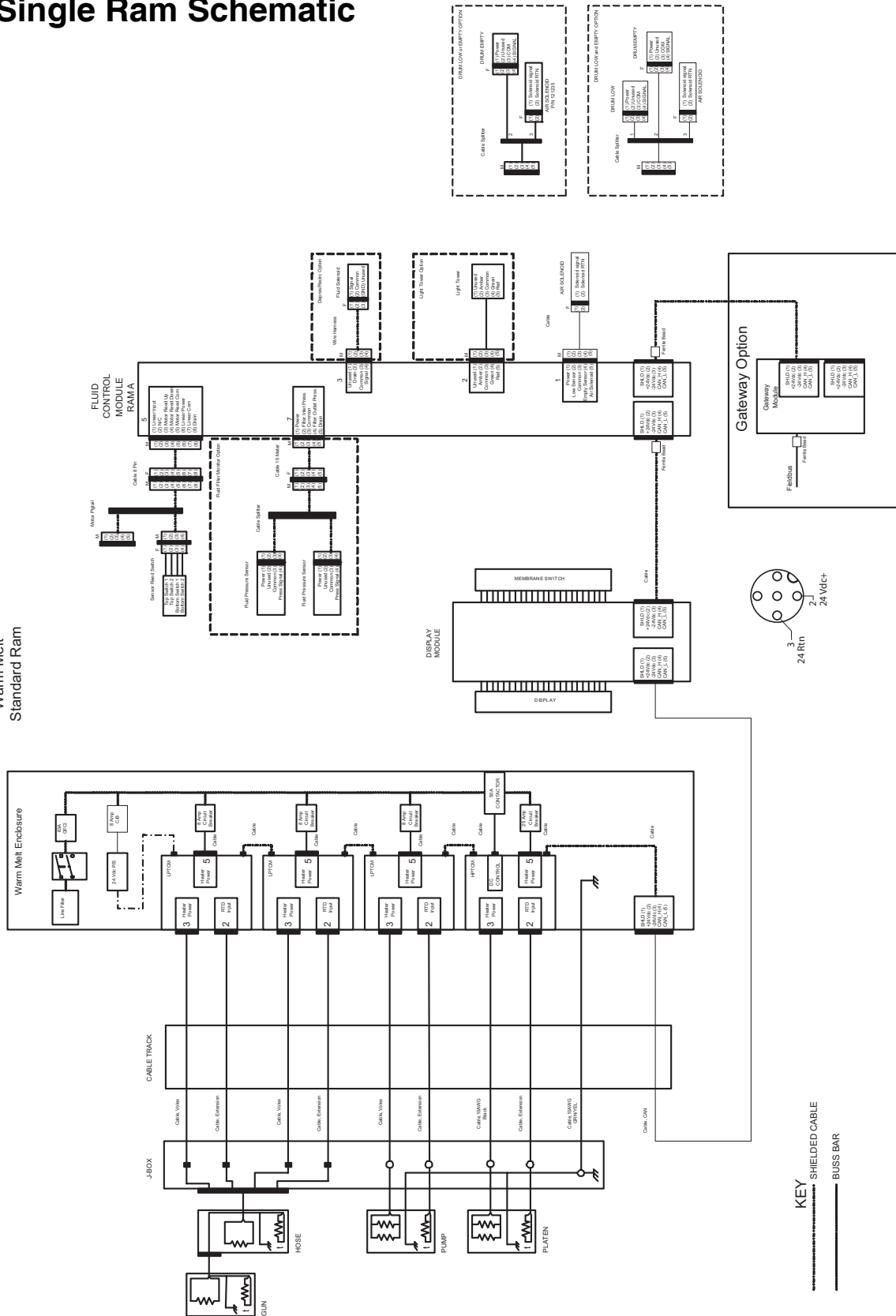

D200 Ram A Schematic

Warm Melt
Ram "A"

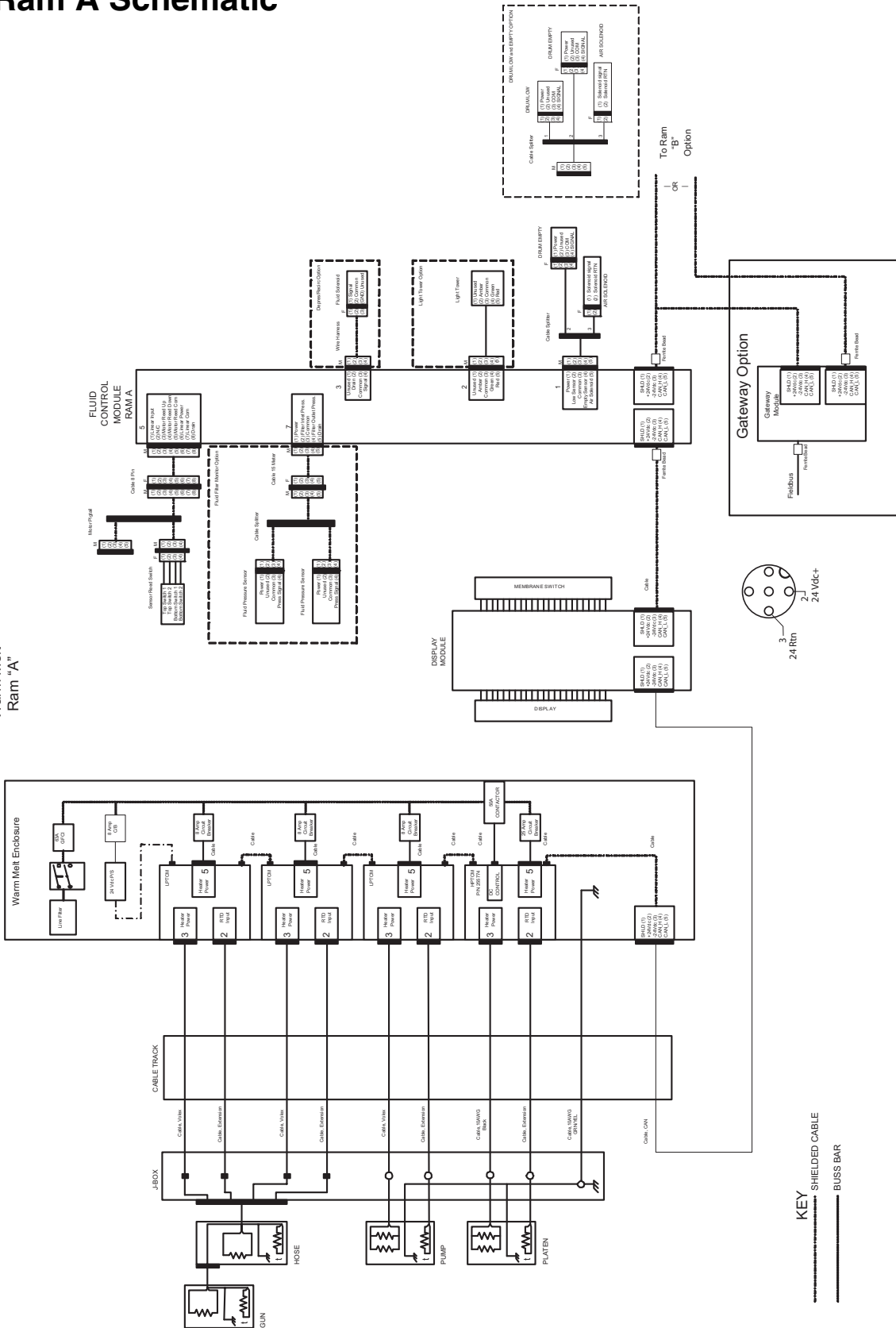

D200 Ram B Schematic

Warm Melt
Ram "B" Option

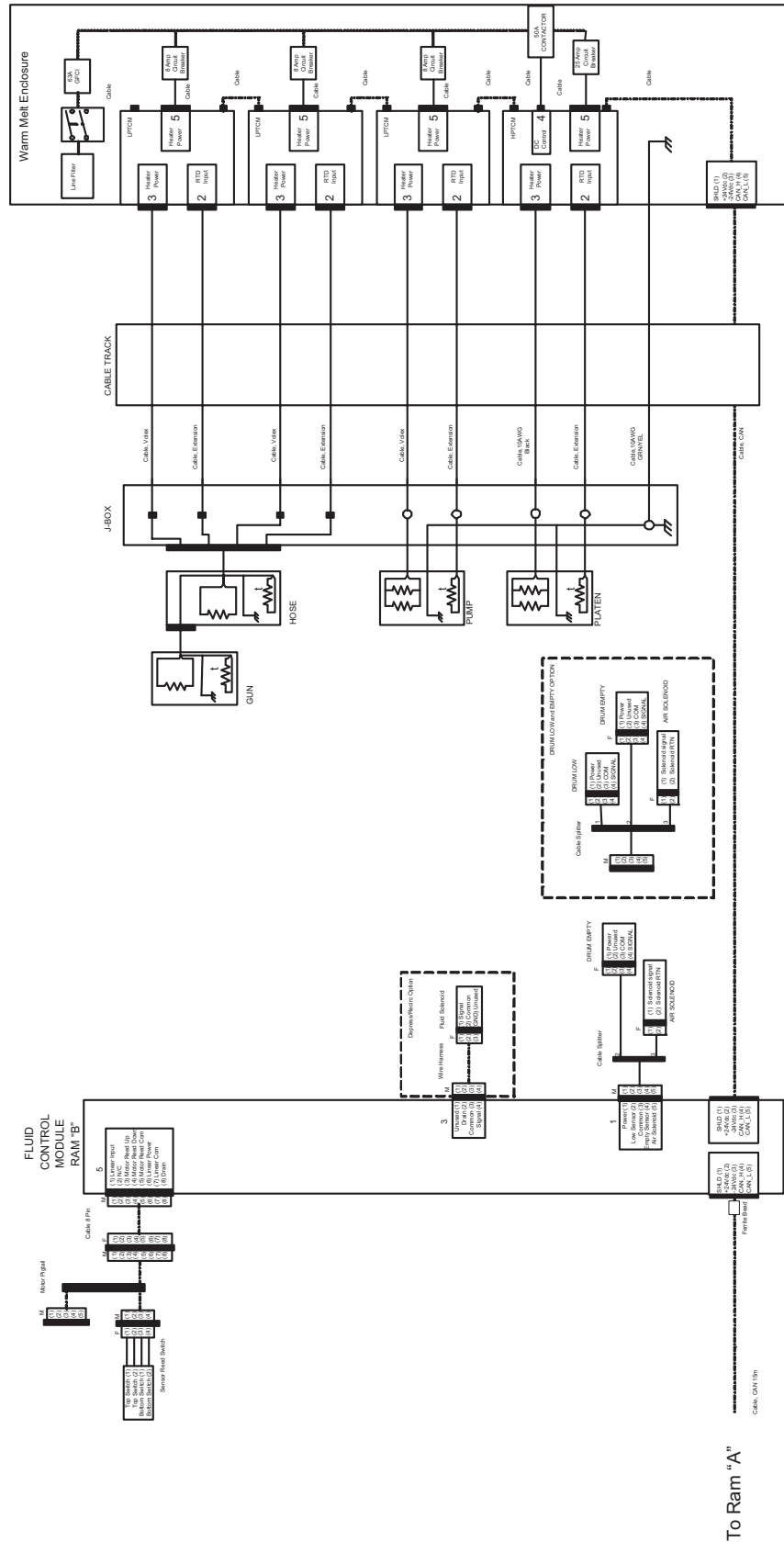

D200 Displacement Pump and Platen Schematics

Platen

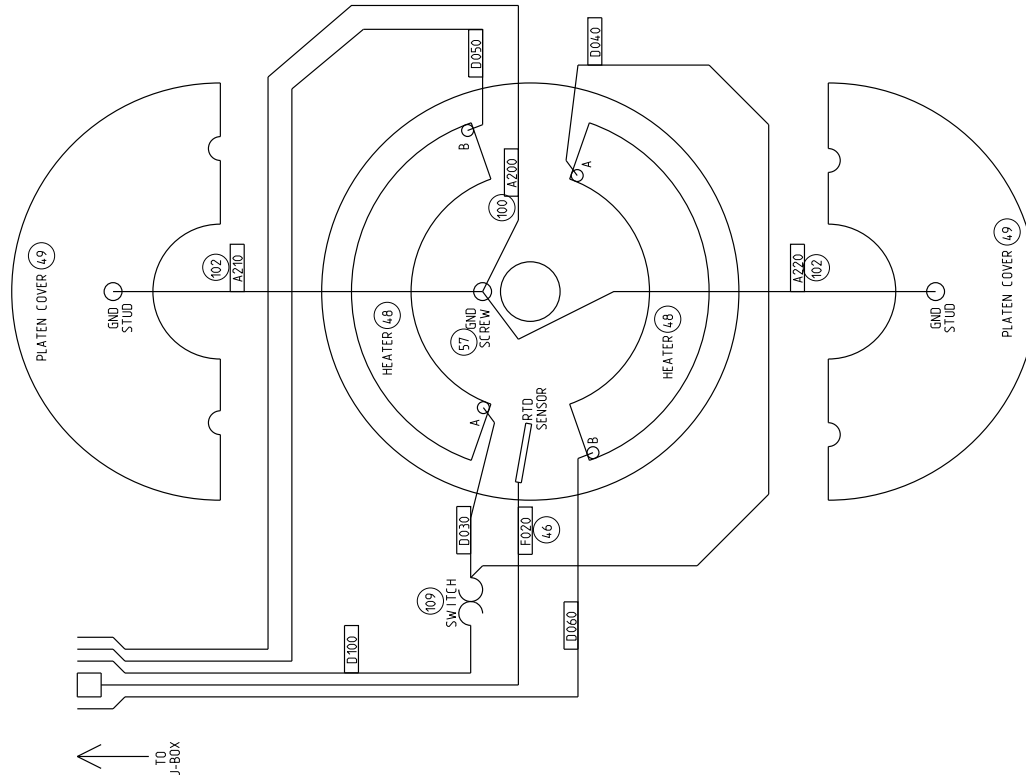

Displacement Pump

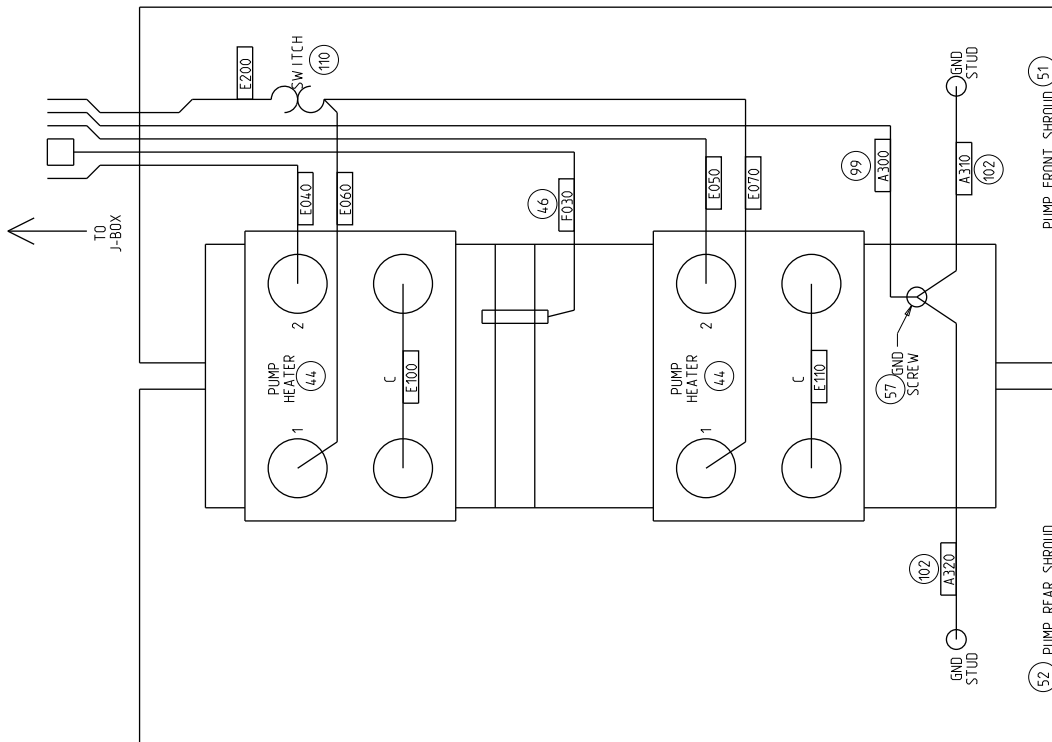

D200 Junction Box Schematic

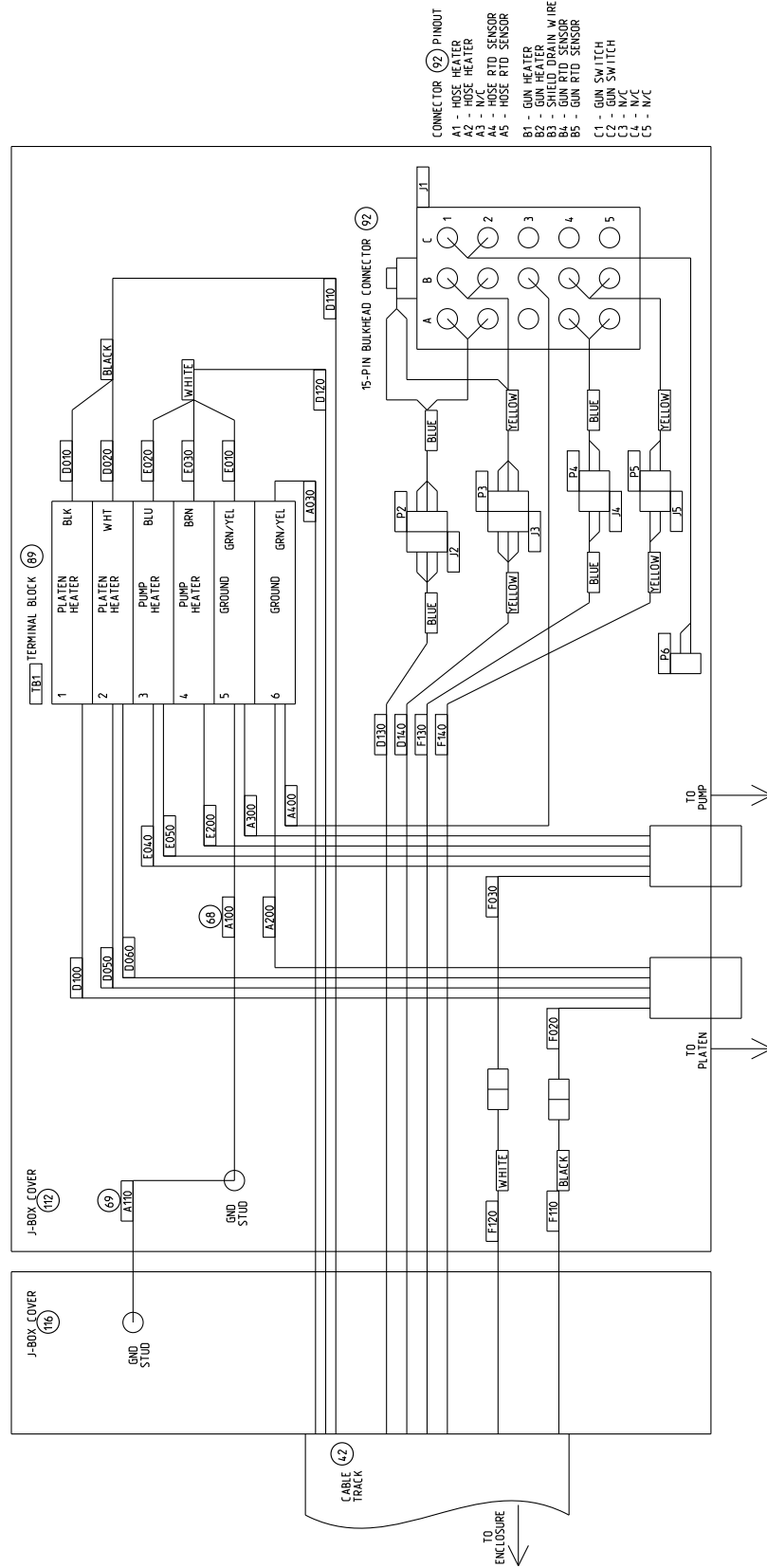

D200 Cable Track Schematic

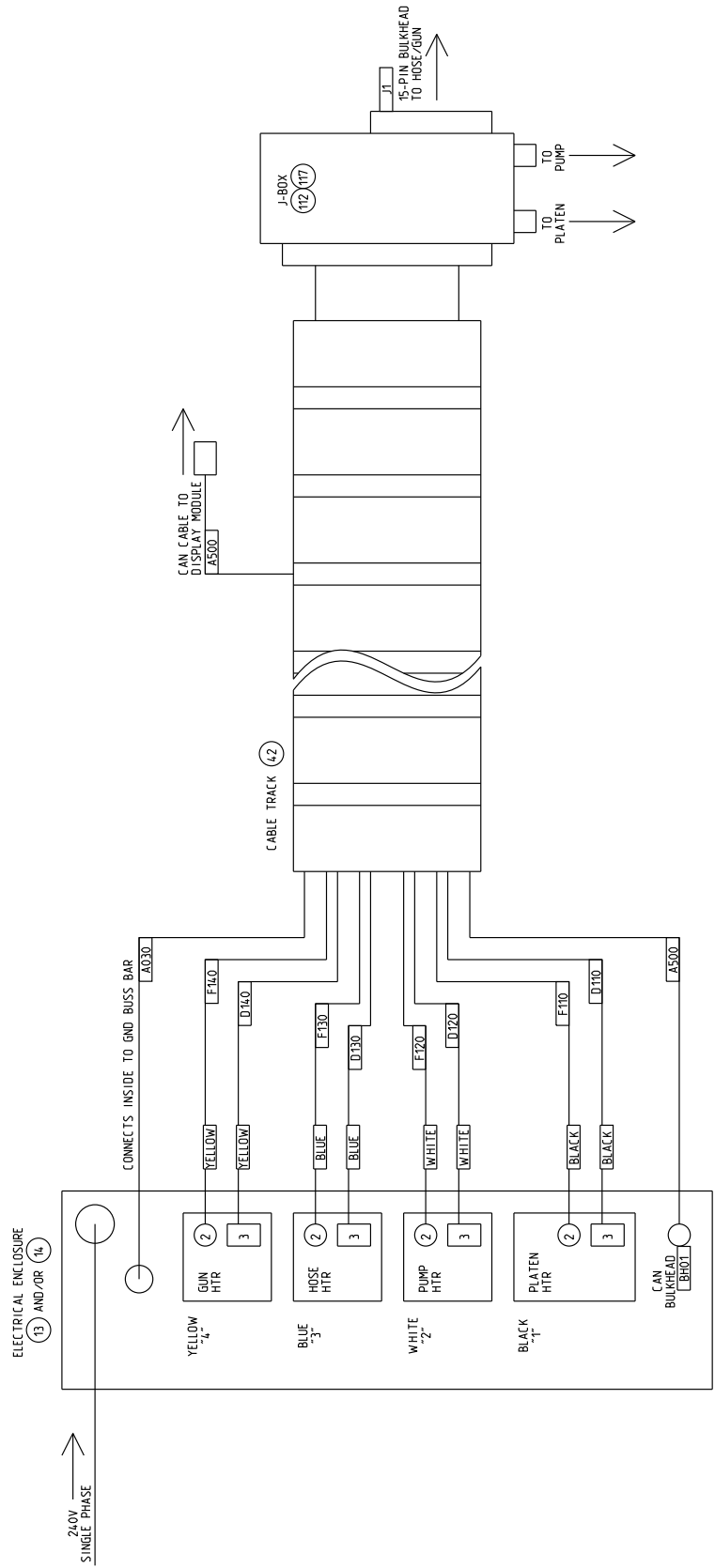

D60 Pump and Platen Schematic

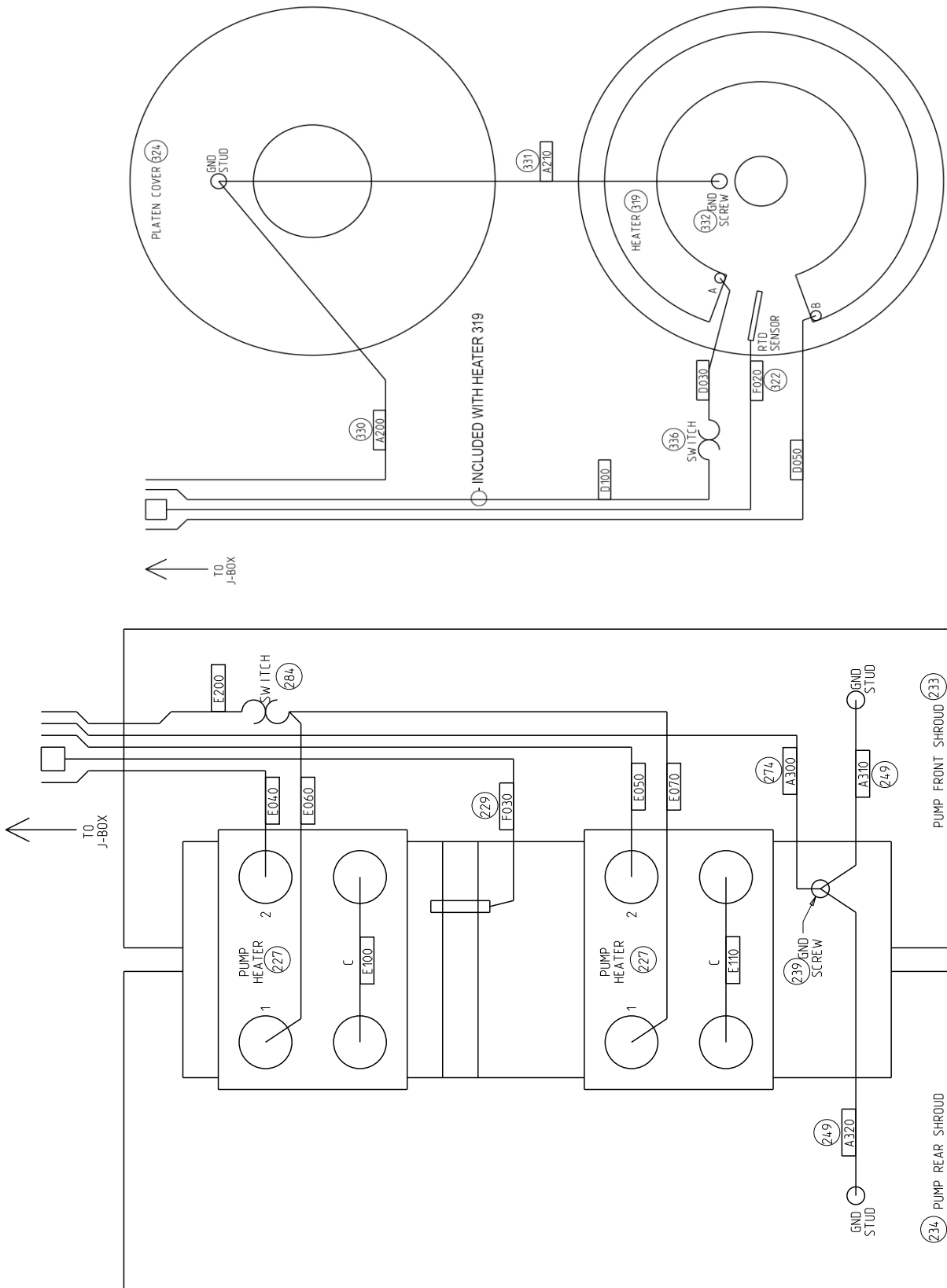

D60 Junction Box Schematic

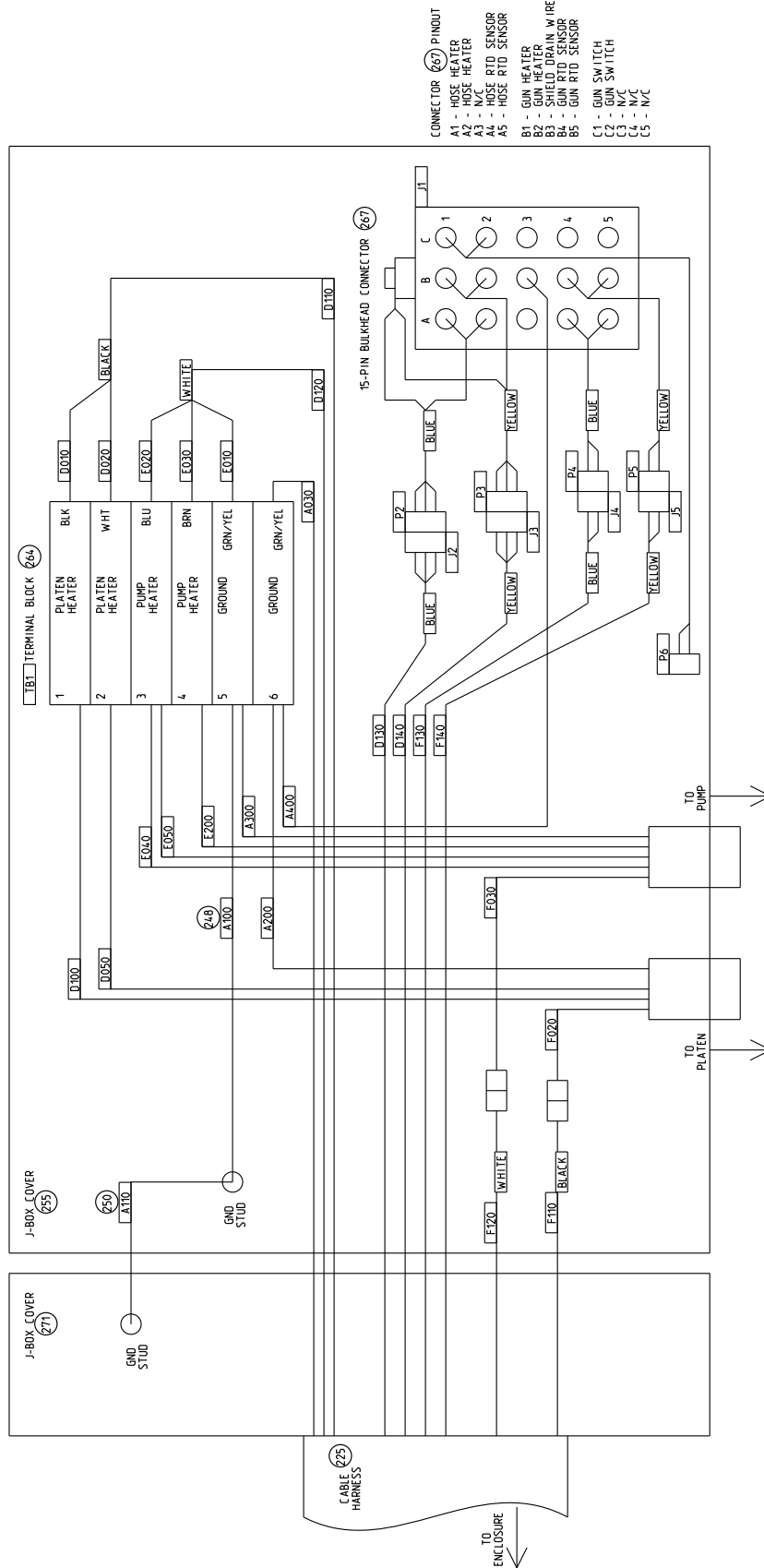

D60 Cable Harness Schematic

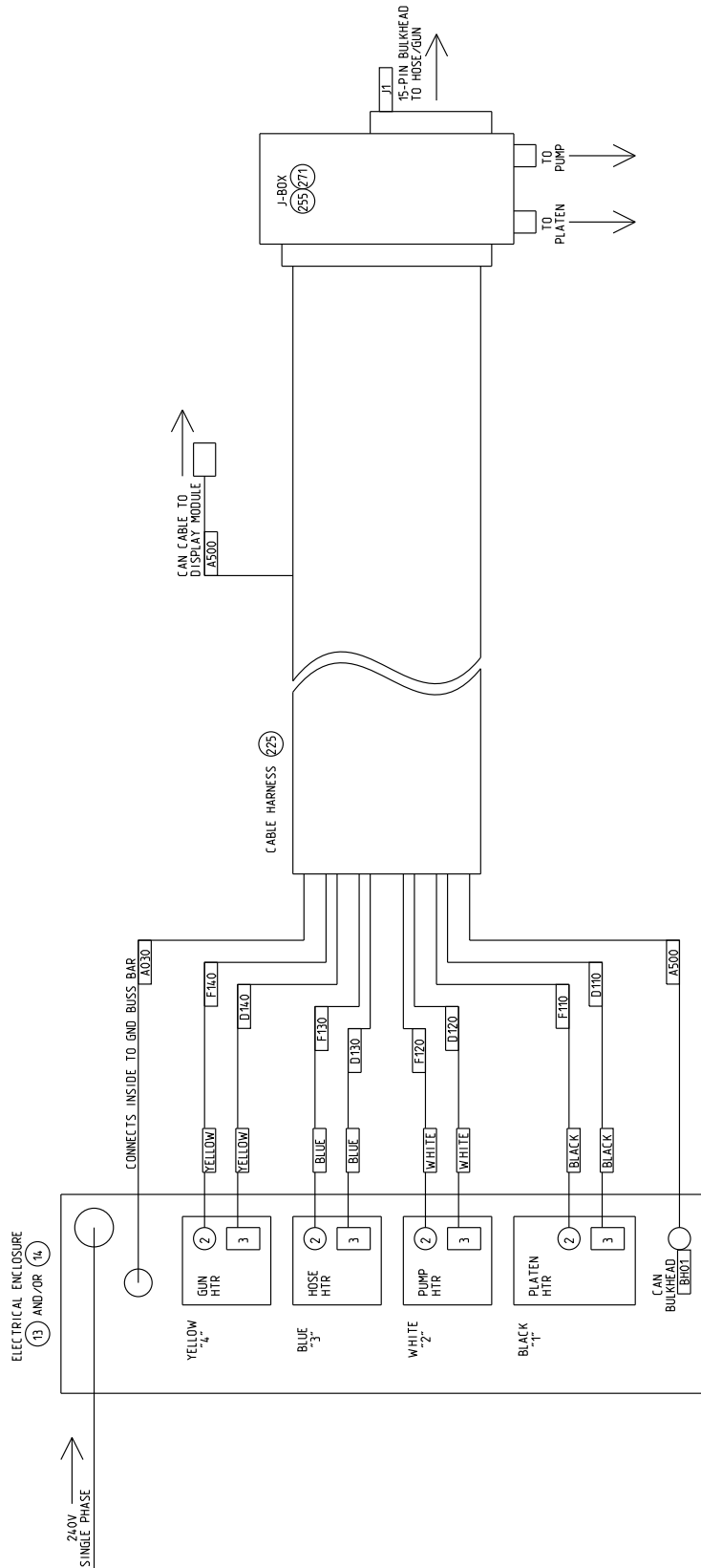

Electrical Enclosure Schematic

4-Zone Medium Enclosure

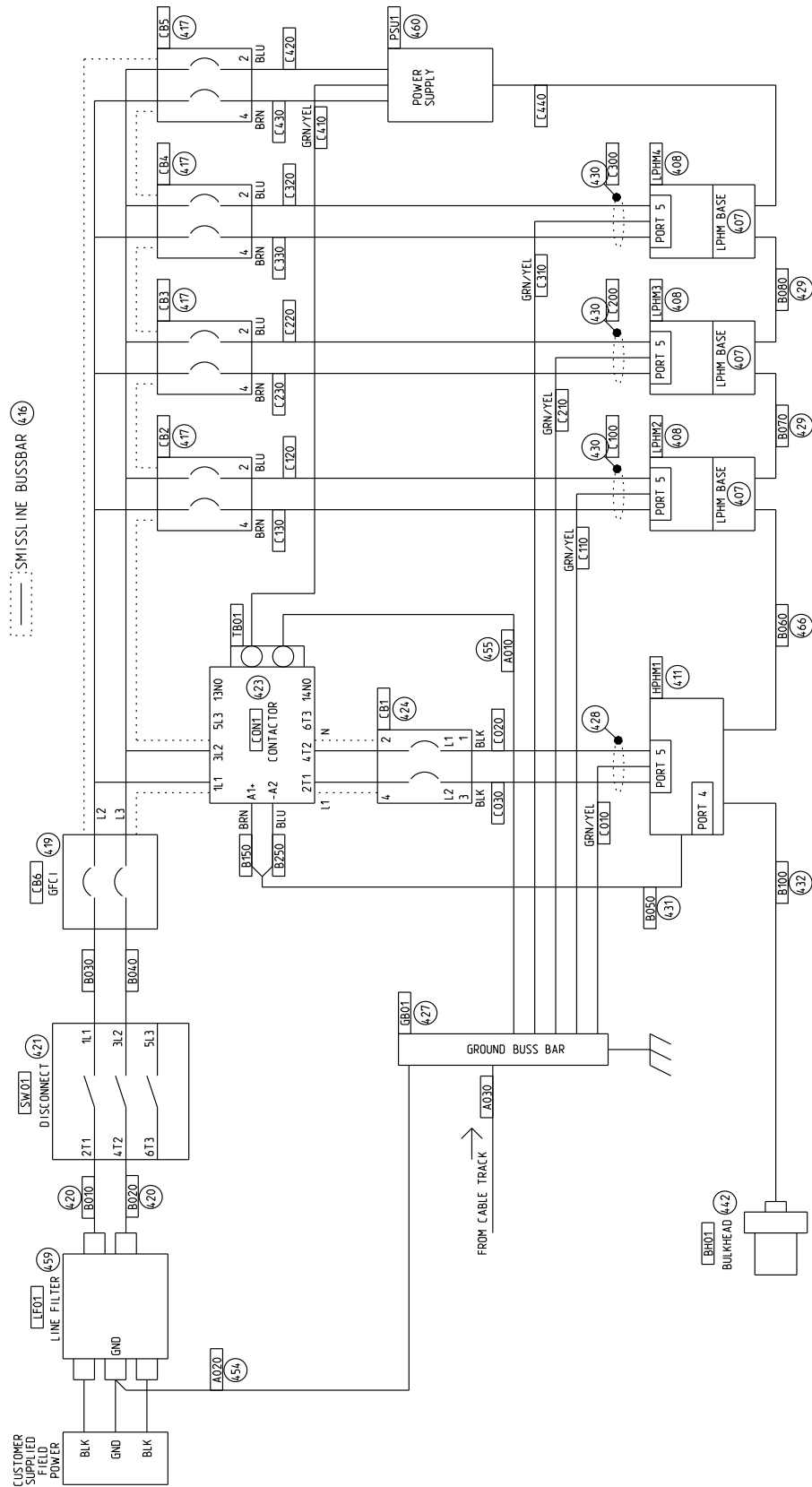

Electrical Enclosure Schematic

4-Zone RAM 'B' Enclosure

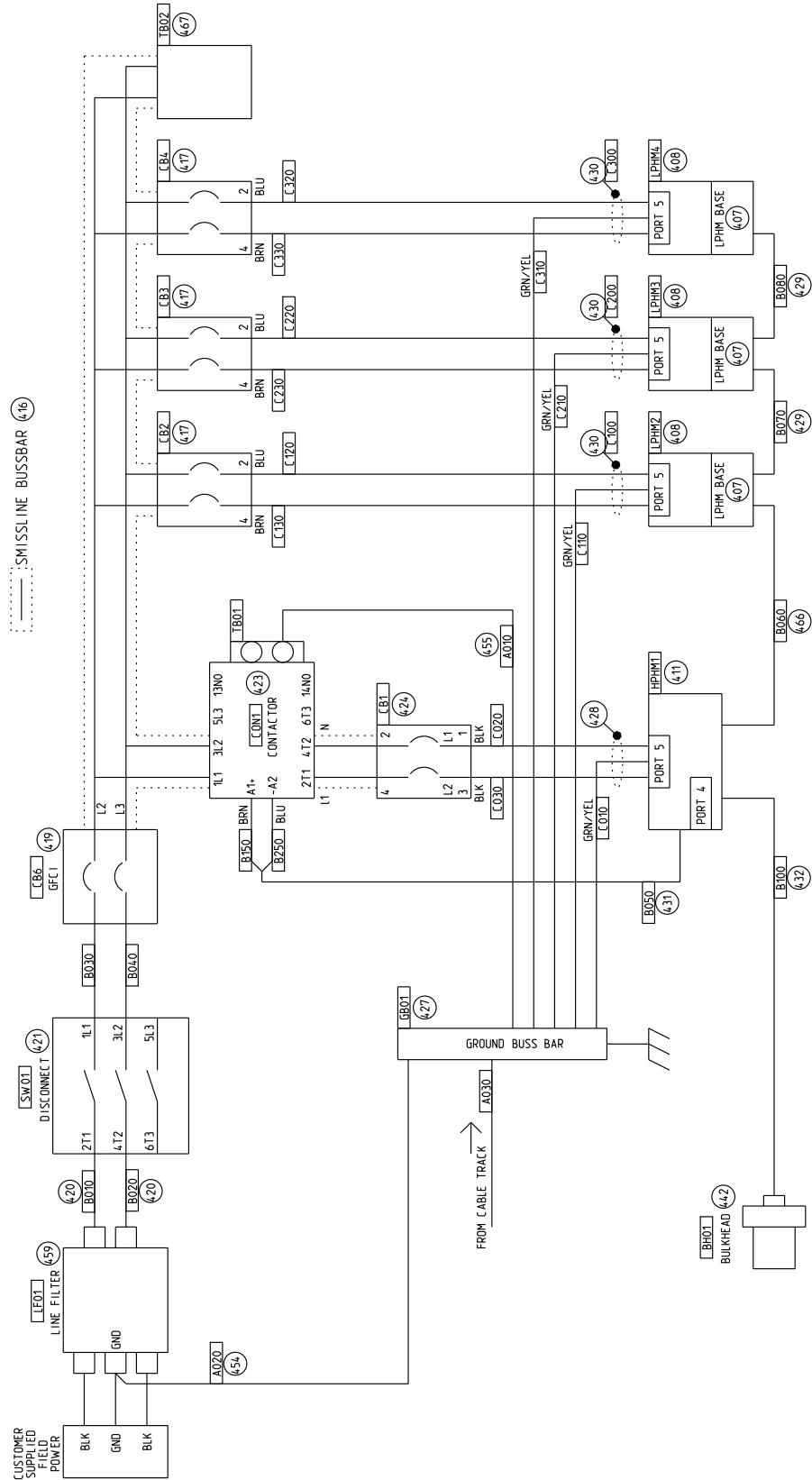

Parts

D200s Rams Shown

Single Supply System or Supply System A

Supply System B

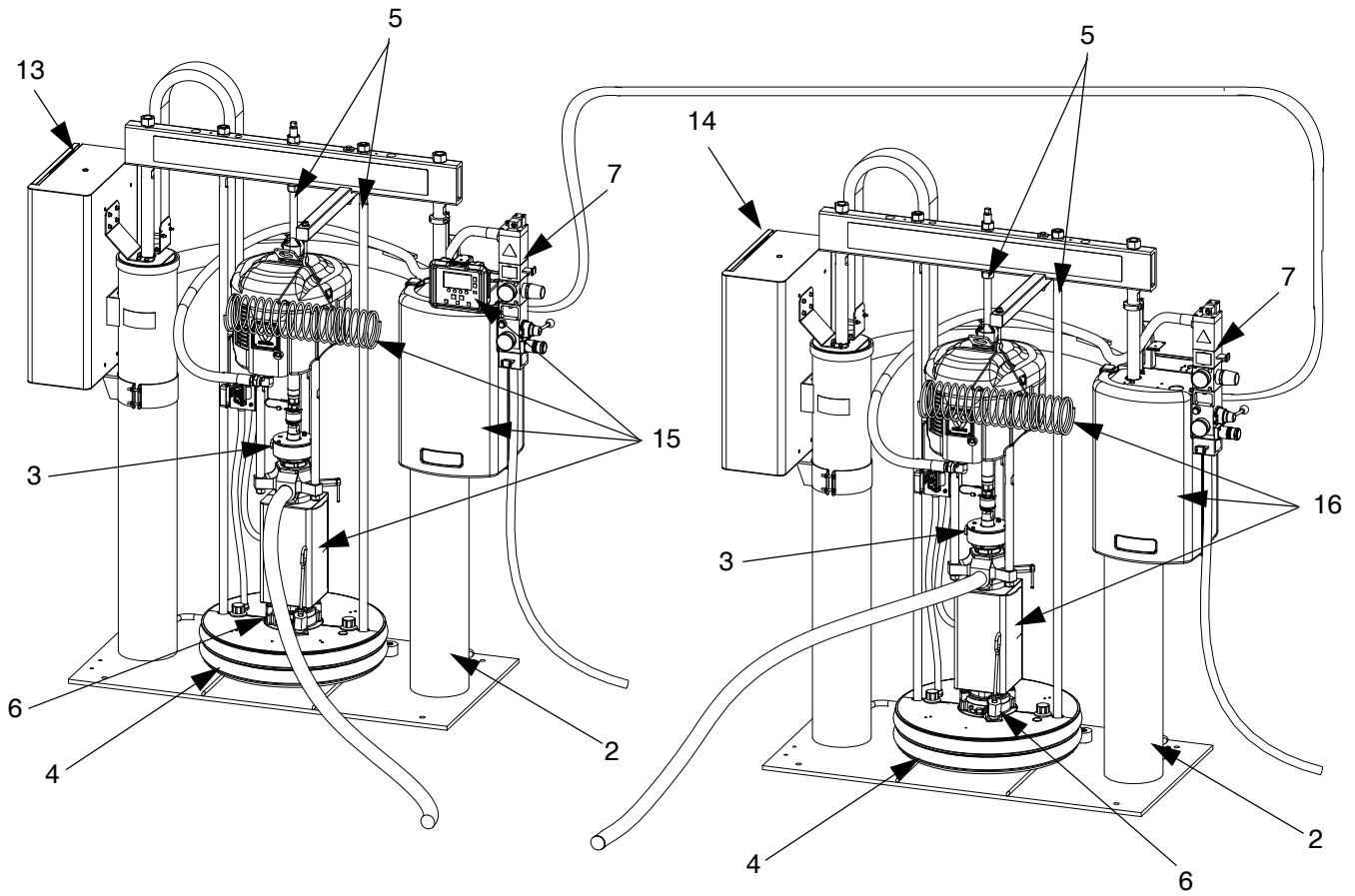

NOTE: See Component Identification, starting on page 9, to identify the components included in your Warm Melt supply system.

Ref. Part	Description	Qty.
2*	RAM ASSEMBLY, D60, 3 in.	1
	RAM ASSEMBLY, D60i, 3 in.	1
	RAM ASSEMBLY, D200s, 6.5 in.	1
	RAM ASSEMBLY, D200si, 6.5 in.	1
	RAM ASSEMBLY, D200, 3 in.	1
	RAM ASSEMBLY, D200i, 3 in.	1
3	PUMP, Check-Mate; see manual 312375 for parts	1
4	24D066 PLATEN, 20 liter, double wiper, cst, polyurethane	1
	24D069 PLATEN, 20 liter, double wiper, sst, polyurethane	1
	24D067 PLATEN, 30 liter, double wiper, cst, polyurethane	1
	24D070 PLATEN, 30 liter, double wiper, sst, polyurethane	1
	24D068 PLATEN, 60 liter, double wiper, cst, polyurethane	1
	24D071 PLATEN, 60 liter, double wiper, sst, polyurethane	1
	257748 PLATEN, 55 gal., PTFE-coated o-ring, EPDM	1
	255319 PLATEN, 55 gal., o-ring, EPDM	1
	255320 PLATEN, 55 gal., o-ring, neoprene	1
5*	257623 KIT, mounting, pump; 3 in.; 20 liter; for NXT 2200 air motors	1
	257624 KIT, mounting, pump; 3 in.; 20 liter; for NXT 3400 and 6500 air motors	1
	255305 KIT, mounting, pump; 3 in.; 55 gal.	1
	255315 KIT, mounting, pump; 6.5 in.; 55 gal.	1
6*	255392 KIT, mounting; Check-Mate pump	1
7*	VALVE, safety relief; located out of view, on back side of air controls	1
	103347 For systems with pumps: P23xxx or P36xxx	
	108124 For systems with pumps: P68xxx	

Ref. Part	Description	Qty.
	ENCLOSURE, electrical (see Electrical Enclosure Parts , page 90)	
13	257158 For single systems and Ram A	1
14	257291 For Ram B	1
15	KIT, warm melt, with display (see Warm Melt Kits for D200 Systems , page 78, or Warm Melt Kits for D60 Systems , page 83)	
	24D009 D60, Ram, WMxxxx Models	1
	24D010 D60, Ram A, TWxxxx Models	1
	24D012 D200, 3 in. Ram, WMxxxx Models	1
	24D013 D200, 3 in. Ram A, TWxxxx Models	1
	24D015 D200, 6.5 in. Ram, WMxxxx Models	1
	24D016 D200, 6.5 in. Ram A, TWxxxx Models	1
16	KIT, warm melt, with no display (see Warm Melt Kits for D200 Systems , page 78, or Warm Melt Kits for D60 Systems , page 83)	
	24D011 D60, Ram B, TWxxxx Models	1
	24D014 D200, 3 in. Ram B, TWxxxx Models	1
	24D017 D200, 6.5 in. Ram B, TWxxxx Models	1

* See *Supply Systems Repair-Parts manual for parts.*

Stainless Steel Ram Conversion Kits

For converting carbon steel Ram to stainless steel.

24K670	D60, Ram, WMxxxx Models	
24K671	D60, Ram A, TWxxxx Models	
24K673	D60, Ram B, TWxxxx Models	
24K675	D200, 3 in. Ram, WMxxxx Models	
24K676	D200, 3 in. Ram A, TWxxxx Models	
24K677	D200, 3 in. Ram B, TWxxxx Models	
24K678	D200, 6.5 in. Ram, WMxxxx Models	
24K679	D200, 6.5 in. Ram A, TWxxxx Models	
24K680	D200, 6.5 in. Ram B, TWxxxx Models	

Warm Melt Kits for D200 Systems

Kit 24D012 (CST), 24K675 (SST) with Display for D200 and D200i Systems

Kit 24D015 (CST), 24K678 (SST) with Display for D200s and D200si Systems

Kit 24D013 (CST), 24K676 (SST) with Display for Ram A of Tandem D200 and D200i Systems

Kit 24D014 (CST), 24K677 (SST) without Display for Ram B of Tandem D200 and D200i Systems

Kit 24D016 (CST), 24K679 (SST) with Display for Ram A of Tandem D200s and D200si Systems

Kit 24D017 (CST), 24K680 (SST) without Display for Ram B of Tandem D200s and D200si Systems

Kit 24D016 Shown

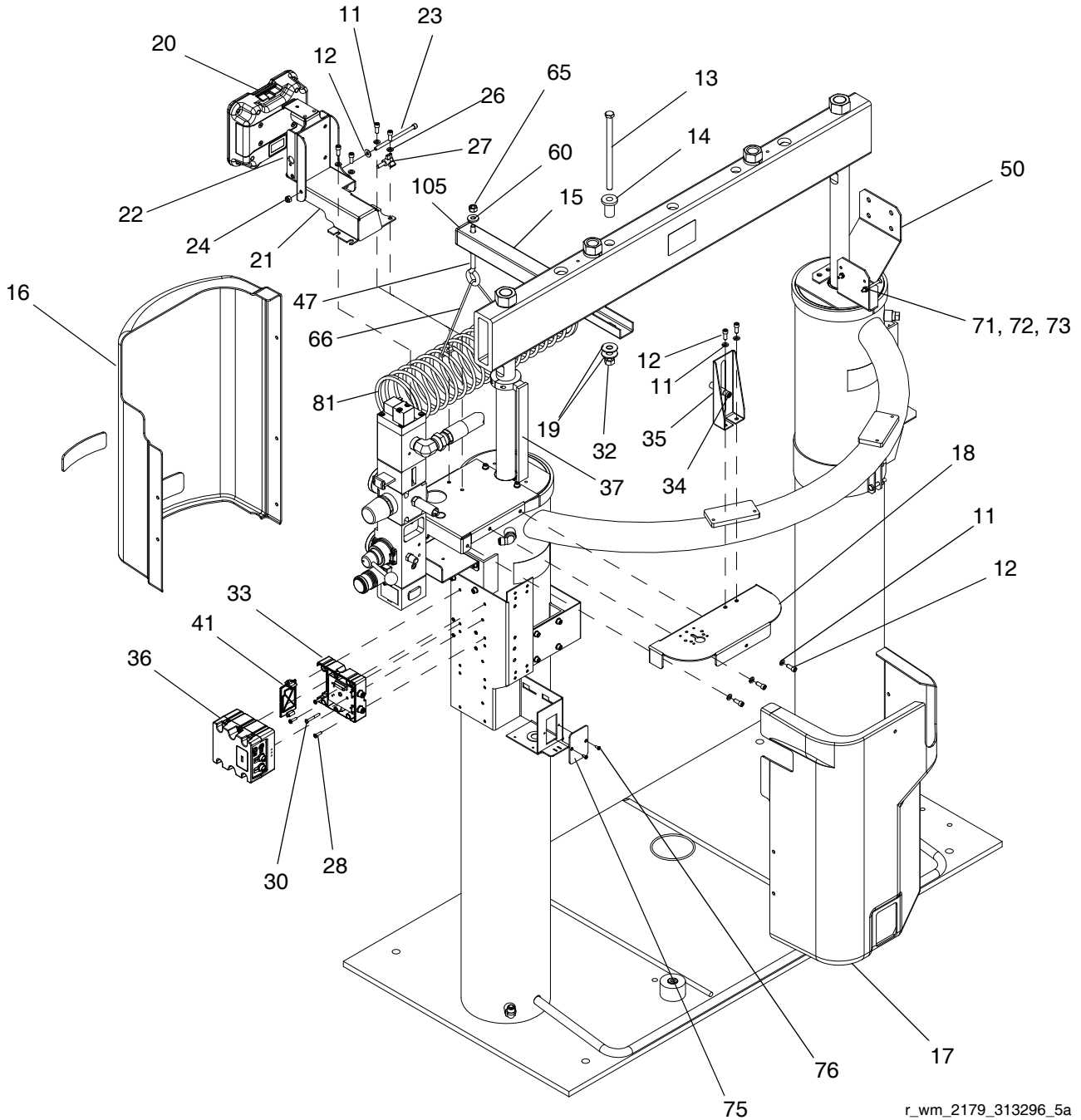

r_wm_2179_313296_5a

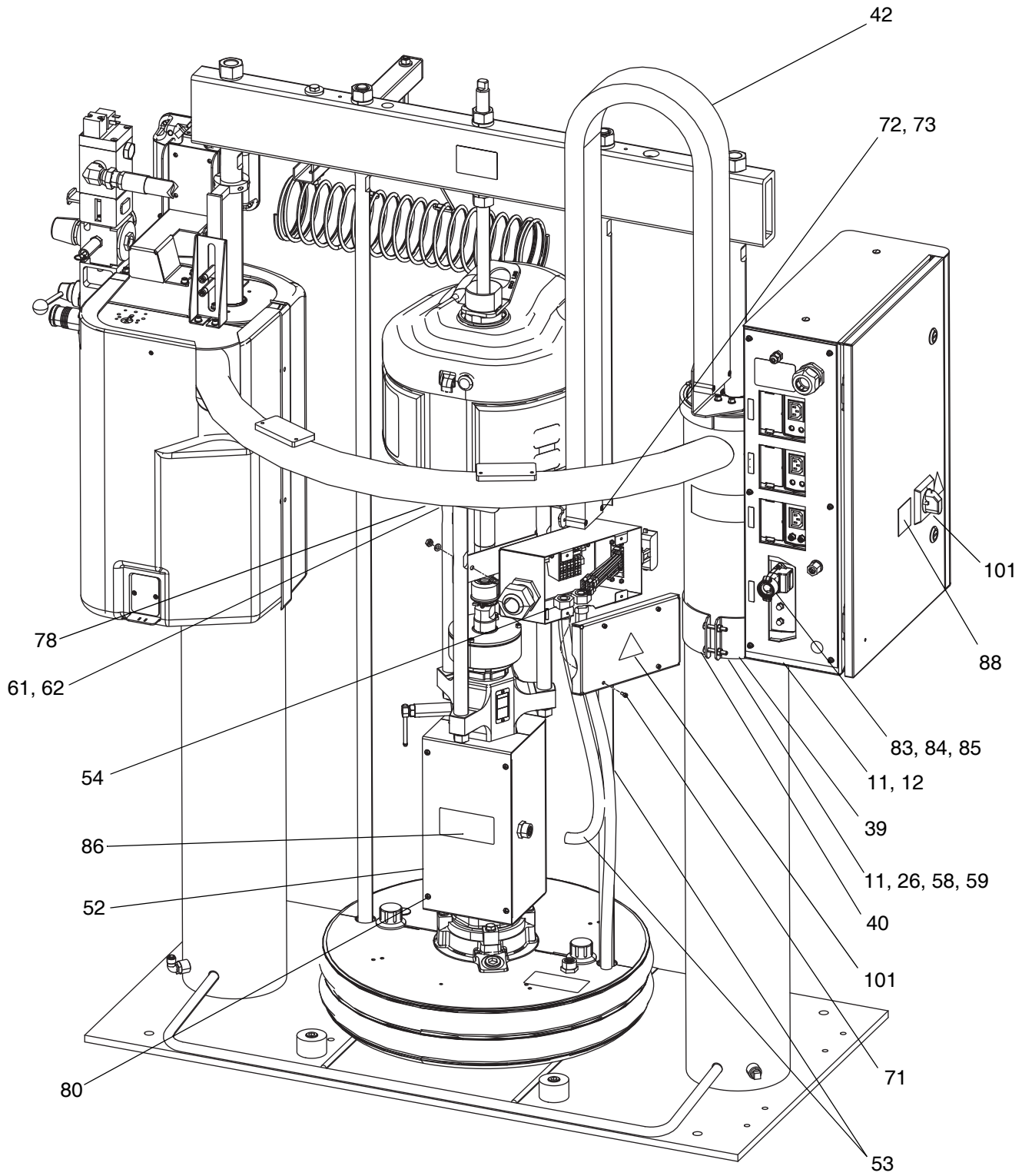

T119984a

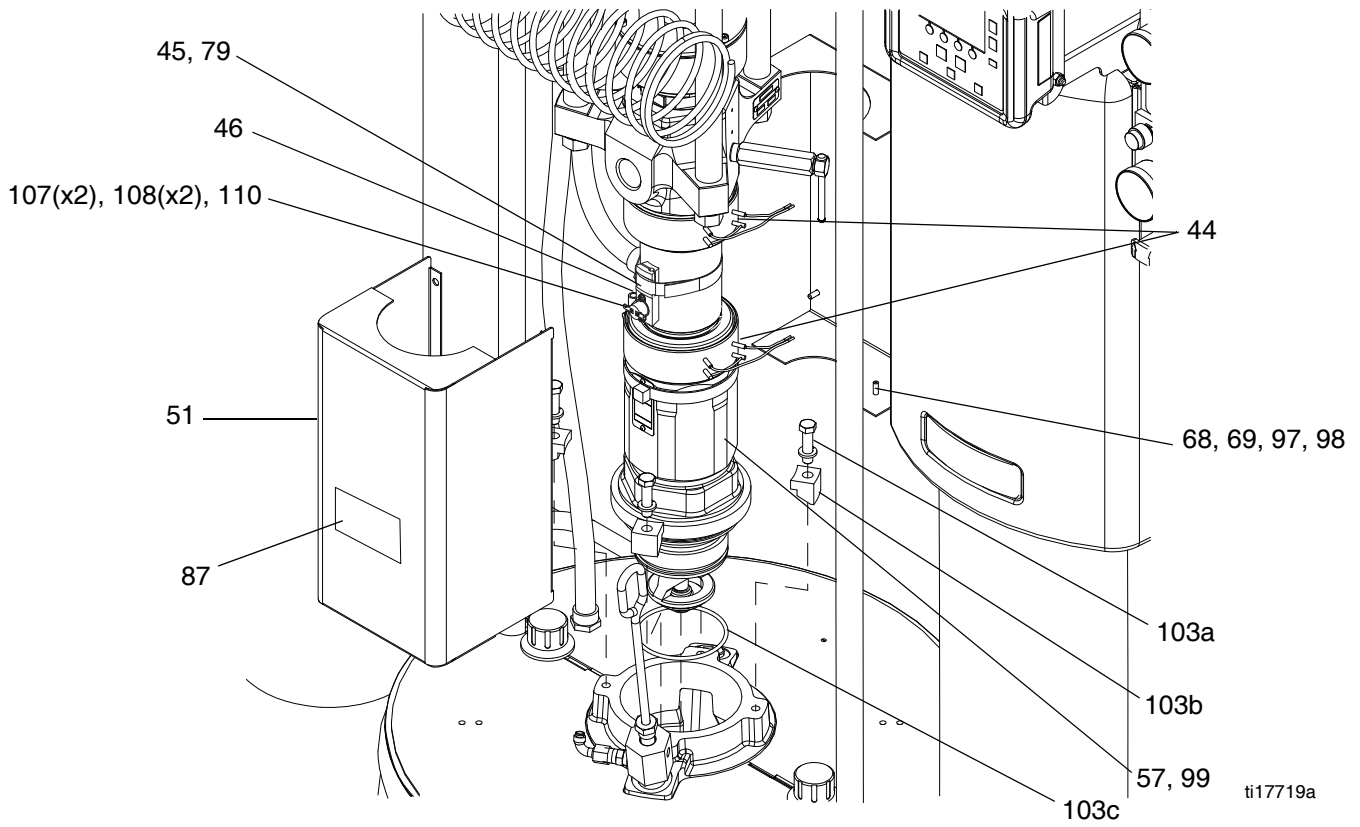

 Torque to 60 +/- 10 in-lbs (6.8 +/- 1.1 N•m)

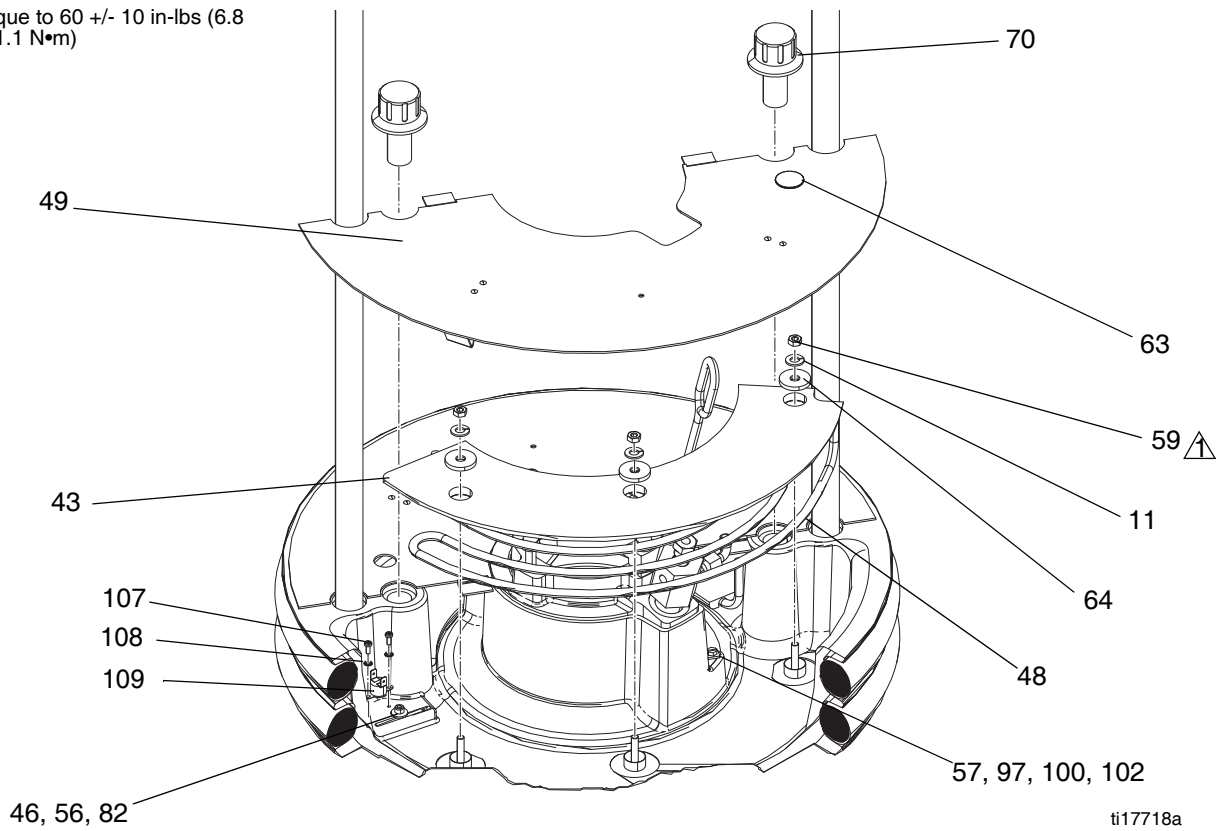

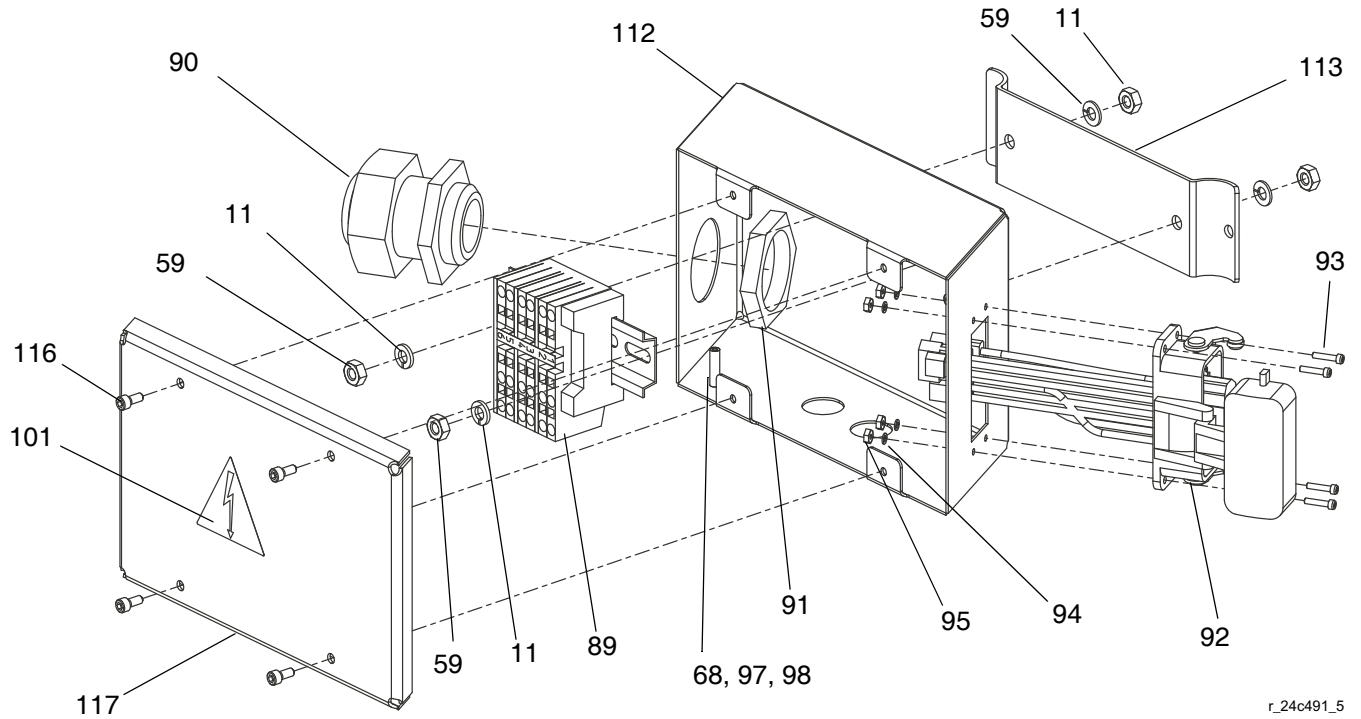

r_24c491_5

D200 Warm Melt Kits

Ref.	Part	Description	Qty.	Ref.	Part	Description	Qty.
				29★		SUPPRESSOR, ferrite bead	1
11✓	100016	WASHER, lock	29	30	121070	SCREW, machine; #8-32 x 1 3/8	1
12	121112	SCREW, cap, sch	15	31★		CABLE, CAN, female/female; 0.5 m	1
13❖	115827	SCREW, cap, hex hd; 7/16-14 unc	1		121001		
14❖	15X270	WASHER, top hat	1		121228	Kits 24D014 and 24D017 only	
15❖	15G347	SUPPORT, hose hanger	1	32❖	101213	NUT, full, hex	1
16		COVER, shroud front	1	33	289697	MODULE, cube, base	1
	†277589	- for 3 in. Ram		34*†❖	122716	SENSOR, inductive, M12	1
	◆277591	- for 6.5 in. Ram		35*†❖		BRACKET, sensor, low/empty	1
17		COVER, shroud rear	1	36■	289696	MODULE, fluid control	1
	†277590	- for 3 in. Ram		37*†❖		ACTUATOR, sensor, low/empty	1
	◆277592	- for 6.5 in. Ram	1			BRACKET, mounting, bottom	1
18		BRACKET, light tower	1	39		- for 3 in. Ram	
	†255383	- for 3 in. Ram			†*	- for 6.5 in. Ram	
	◆15R108	- for 6.5 in. Ram			◆❖	BRACKET, mounting	1
19❖	100696	WASHER, plain	2		†*	- for 3 in. Ram	
20❖■	24F493	MODULE, display	1	40		- for 6.5 in. Ram	
21❖✓		BRACKET, pendant pivot	1		†*	BRACKET, mounting	1
22❖✓		BRACKET, mounting, assy	1		◆❖	- for 3 in. Ram	
23❖✓		SCREW, cap, sch; 1/4-20 unc	1	41❖	277674	ENCLOSURE, cube door	1
24❖	102040	NUT, lock, hex	1	42✓	257163	CABLE, track	1
25★	‡123328	CABLE, splitter, FCM, empty/air	1	43●		CONDUCTOR, block, heater	2
	❖15X968	CABLE, FCM, low/hi/air	1	44+✓★	121980	HEATER, pump, 725 watt	2
	16C377	CABLE, M12, DIN	1	45+★	16J890	SUPPORT, sensor	1
26❖	110755	WASHER, plain	5	46●+✓	16D383	SENSOR, RTD, shielded	2
27❖	121253	KNOB, display	1	❖			
28	114417	SCREW, self tap, pan hd	4	47❖	119832	BOLT, eye, 3/8-14 x 6	1
				48●✓	15V427	HEATER, coil	2

Parts

Ref.	Part	Description	Qty.	Ref.	Part	Description	Qty.
49	●✓	COVER, platen front, assy.	2	102	✓✘ 16A574	WIRE, ground	4
✘				103	255392	KIT, mounting, displacement pump	1
50		BRACKET, mounting, top	1	103a	102637	SCREW, cap	4
	†*	- 3 in. Ram		103b	276025	CLAMP	4
	◆‡	- 6.5 in. Ram		103c	109495	O-RING	1
51	†✓★	15W706 ENCLOSURE, pump, front	1	104	★	STUD	6
52	†✓★	15W707 ENCLOSURE, pump, rear	1	106	★	15Y051 CABLE	1
53		CONDUIT; 12.9 mm	4	107		124131 SCREW	4
54		COUPLER, conduit	4	108		103187 WASHER, lock	4
56	117026	SCREW, shcs; m5 x 12	1	109	✓★	15B137 SWITCH, thermal	1
57	✓★	116343 SCREW, ground	2	110	✓★	16K094 SWITCH, overtemp, horizontal	1
58		SCREW, cap, hex hd	4	111	★	114958 STRAP TIE	7
	100014	- for 3 in. ram		112		16A539 JUNCTION BOX	1
	100058	- for 6.5 in. ram		113		16A543 BRACKET	1
59	✓	100015 NUT, hex mscr	12	114		299653 SHRINK TUBE	1
60	❖	100133 WASHER, flat	2	115		C33037 TAPE, fiberglass	1
61	C19837	SCREW, cap, hex hd	2	116		112788 SCREW	4
62	●	STUD, 3/8-16 x 1.25	6	117		16A541 COVER, junction box	1
63	●●	PLUG, finishing; 13/16 in., nickel plated	1				
64	176692	WASHER, flat	6				
65	❖	100307 NUT, hex	2				
66	❖	C34132 HANGER	1				
67	15Y051	CABLE, M12	1				
68	123507	WIRE, grounding	1				
69	16H441	WIRE, grounding	1				
70	●●	FASTENER, platen, cover	2				
71	120223	SCREW, machine, flat hd	4				
72	100020	WASHER, lock	4				
73	100179	NUT, hex mscr	4				
74	111218	CAP, tube	1				
75		COVER	1				
76	121255	SCREW, countersunk; 6-32 x 0.38	2				
78	16M941	BRACKET, cable and rack	1				
79	C31012	CLAMP	1				
80	110637	SCREW, machine, pan hd	4				
81	❖	119958 SPRING, hose hanger	1				
82	110170	WASHER	1				
83	⊗	O-RING	1				
84	⊗	CONNECTOR, power, female, 3 pin	1				
85	⊗	COVER, connector	1				
86	▲	15J075 LABEL, warning	2				
87	▲	15H668 LABEL, warning	1				
89	✓	RAIL, din, assy.	1				
90		BUSHING, strain relief; m40	1				
91		NUT, strain relief; m40	1				
92	✓	24B810 CONNECTOR, bulkhead; 15 pin	1				
93	113970	SCREW, socket hd cap	4				
94	C19208	WASHER, lock	4				
95	102794	NUT, hex	4				
97	111640	WASHER, lock	6				
98	100166	NUT, full hex	5				
99	✓	16A355 WIRE, ground, pump	1				
100	✓✘	16A356 WIRE, ground, platen	1				
101	▲	196548 LABEL, caution	1				

★ Not shown.

▲ Replacement Danger and Warning labels, tags, and cards are available at no cost.

† Kit 24D012 only.

◆ Kit 24D015 only.

❖ Kits 24D013 and 24D016 only in tandem supply systems.

❖ Parts included in Hose Hanger Kit 234966 (purchase separately).

‡ Parts included in Low or Empty Sensor Kit 255469 (purchase separately).

✘ Parts included in Drum Low and Empty Sensor Kit 24C530 (purchase separately).

* Parts included in 3 in. Ram Bracket Mounting Kit 24C628 (purchase separately).

‡ Parts included in 6.5 in. Ram Bracket Mounting Kit 24C660 (purchase separately).

● Parts included in Platen Heater Kit 24C493 (purchase separately).

† Parts included in Pump Heater Kit 24C495 (purchase separately).

▶ Parts included in Platen Cover Kit 255691 (purchase separately).

✓ Parts only available in Display Mounting Kit 24C653 (purchase separately).

⊗ Parts only available in Cover Connector Kit 256883 (purchase separately).

■ Replacement electronic components do not have Warm Melt specific software installed. Therefore, use software upgrade token 25D885 to install software before use.

Warm Melt Kits for D60 Systems

Kit 24D009 (CST), 24K670 (SST) with Display for D60 and D60i Systems

Kit 24D010 (CST), 24K671 (SST) with Display for Ram A of Tandem D60 and D60i Systems

Kit 24D011 (CST), 24K673 (SST) without Display for Ram B of Tandem D60 and D60i Systems

Kit 24D010 Shown

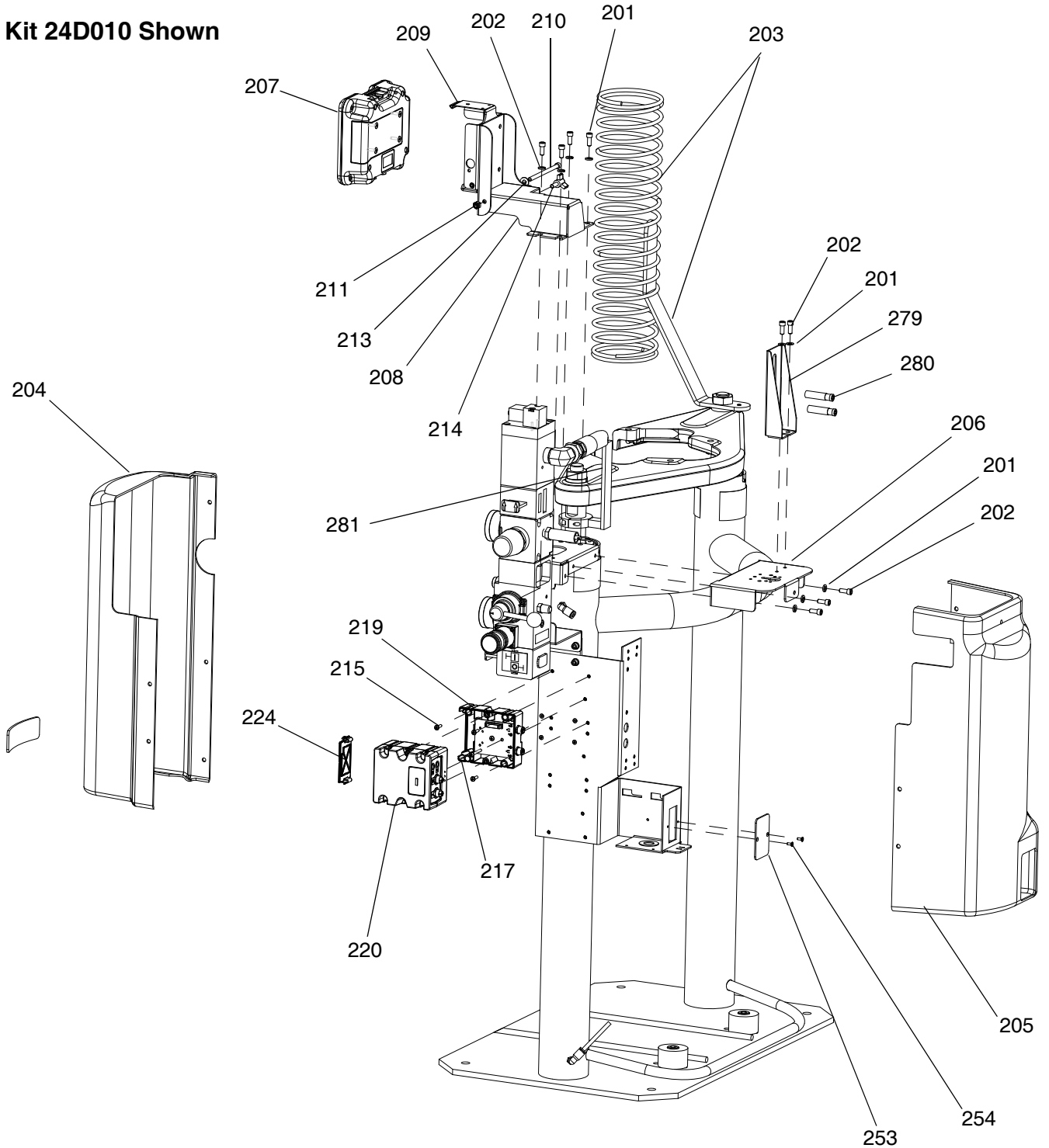

r_wm29yy_31329b6_5

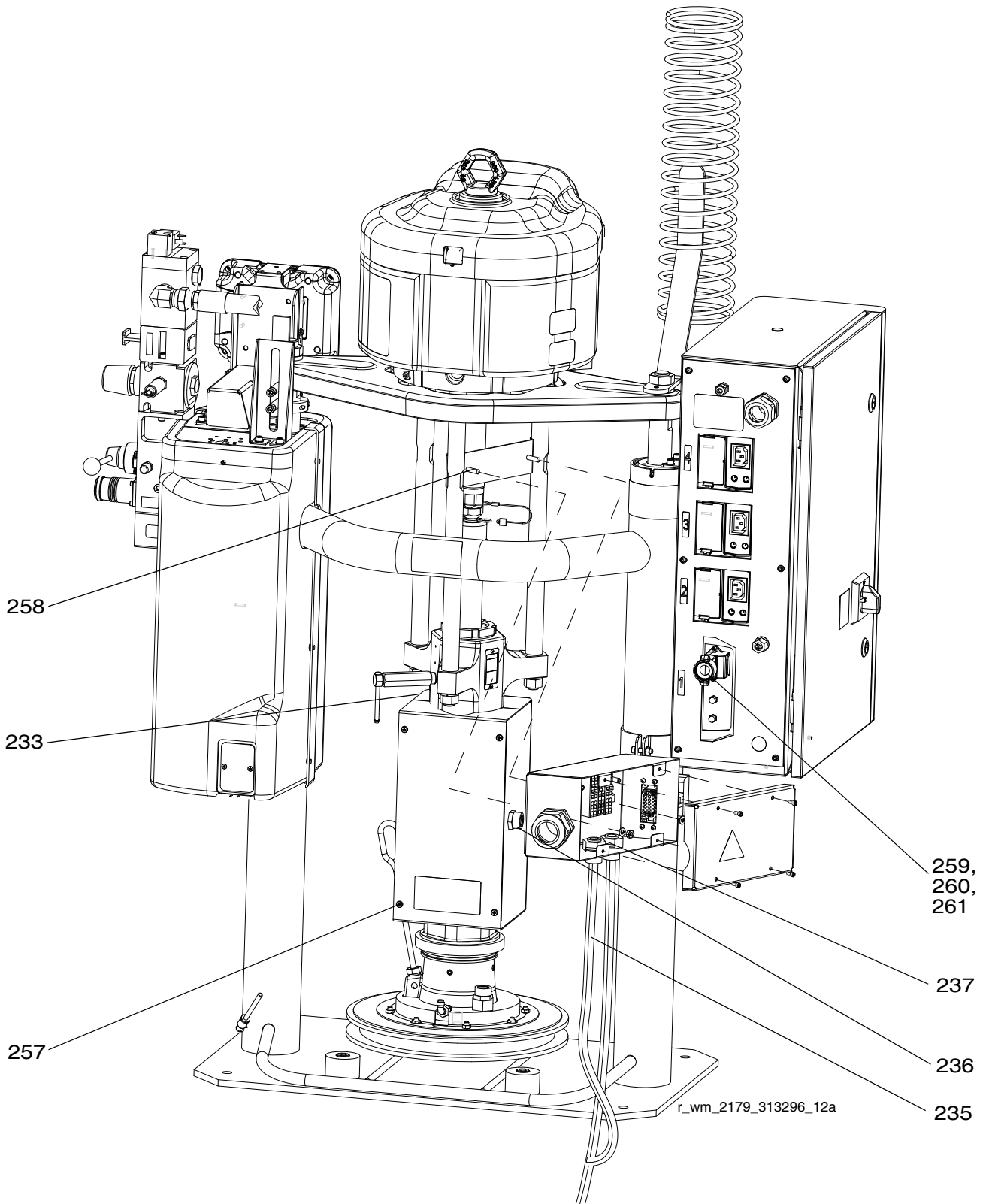

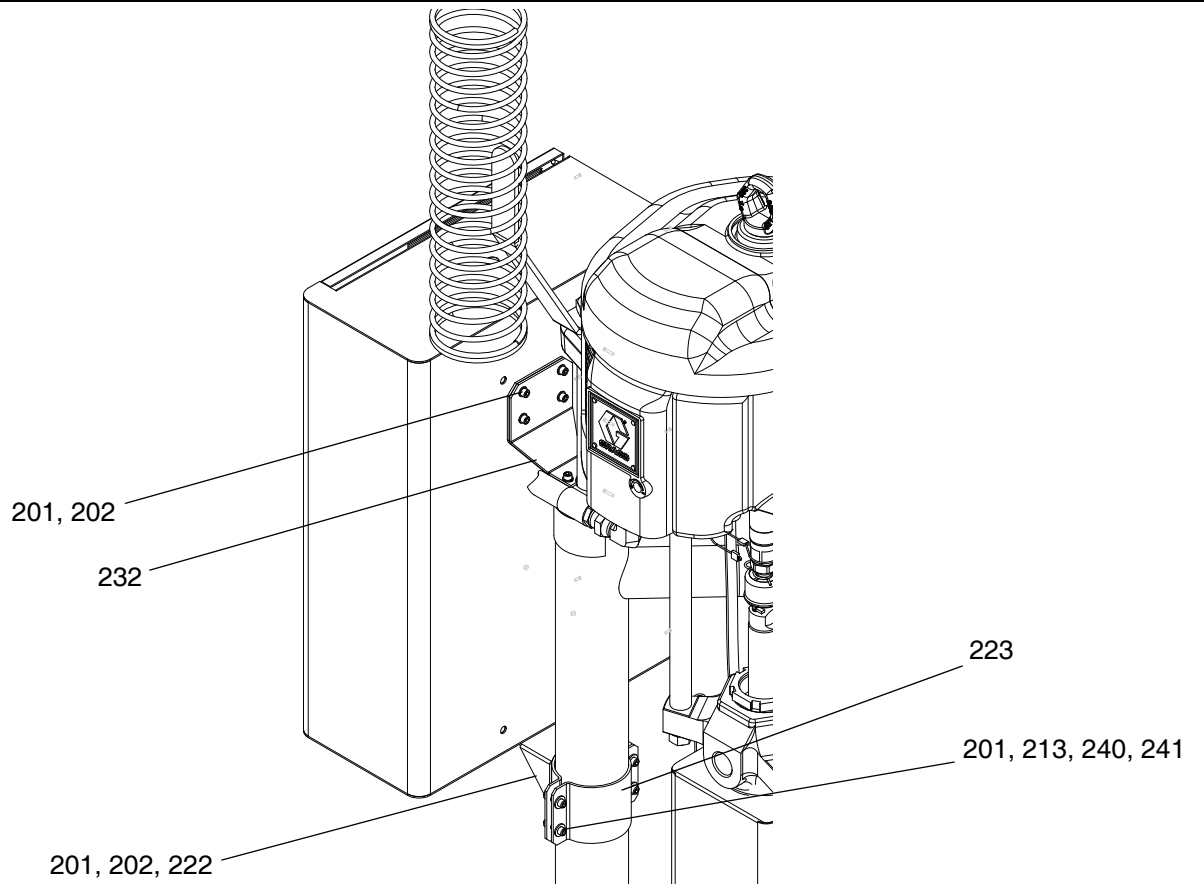
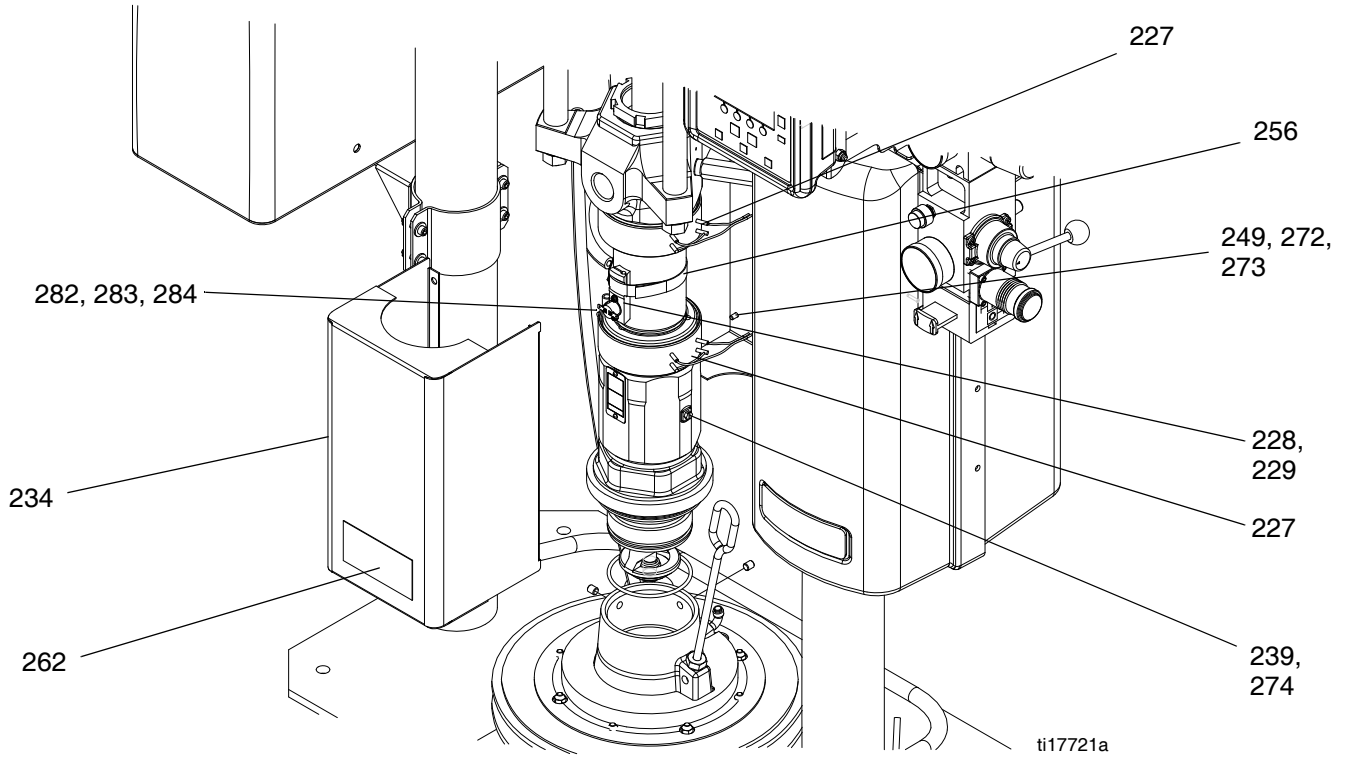

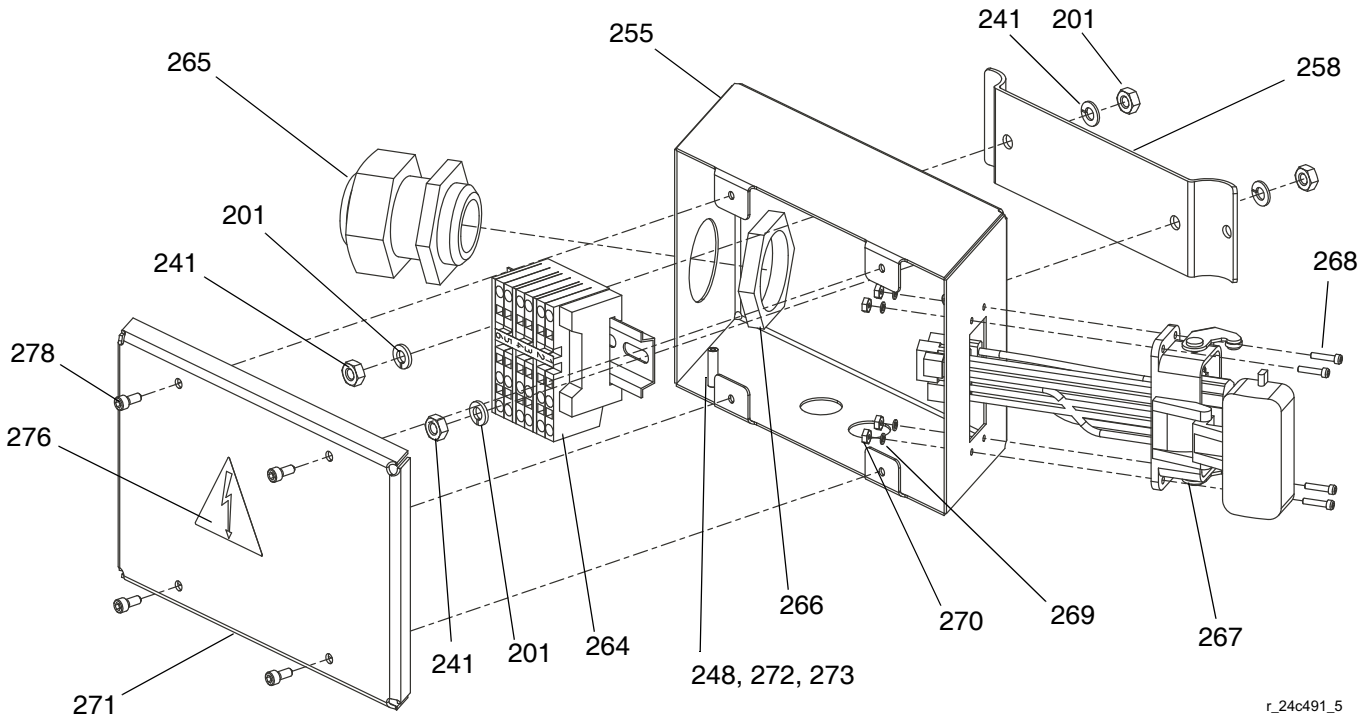

r_24c491_5

D60 Warm Melt Kits

Ref.	Part	Description	Qty.	Ref.	Part	Description	Qty.
201	100016	WASHER, lock	31	224	277674	ENCLOSURE, cube door	1
202	121112	SCREW, cap, sch	23	225★	16C430	HARNES	1
203	288543	BRACKET, hose spring	1	227†	121980	HEATER, pump; 725 watt	2
204	277589	COVER, shroud front	1	228†	16J890	SUPPORT, sensor	1
205	277590	COVER, shroud rear	1	229†	16D383	SENSOR, RTD, shielded	1
206	255383	BRACKET, light tower	1	232*		BRACKET, mounting, accessory box	1
207☛■	24F493	MODULE, display	1	233†	15W706	ENCLOSURE, pump, front	1
208☛✓		BRACKET, pendant pivot	1	◆	16K771	ENCLOSURE, pump, front, SST	
209☛✓		BRACKET, mounting, assy	1	234†	15W707	ENCLOSURE, pump, rear	1
210☛✓		SCREW, shcs; 1/4 unc x 4.25	1	◆	16K772	ENCLOSURE, pump, rear SST	
211☛✓	102040	NUT, lock, hex	1	235		CONDUIT; 12.9 mm	2 ft
212★				236		COUPLER, conduit	3
	16C377	CABLE, M12; Kits 24D009/24K670 only	1	239	116343	SCREW, ground	1
	15X968	CABLE, splitter, FCM empty/air; Kits 24D010, 24D011, 24K671, 24K673 only	1	240	100014	SCREW, cap, hex hd	4
213☛✓	110755	WASHER, plain	1	241	100015	NUT, hex mscr	8
214☛✓	121253	KNOB, display	1	247★	15Y051	CABLE, M12, 8 pin, f/m	1
215	114417	SCREW, self tap, pan hd	4	248	123507	WIRE, grounding, panel	1
216★	123375	SUPPRESSOR, ferrite bead	1	249	16A574	WIRE, grounding, door	2
217	121070	SCREW, machine; #8-32 x 1 3/8	1	250	16H441	WIRE, grounding	1
218★	121001	CABLE, CAN, female / female; 1m	1	253		COVER	1
219	289697	MODULE, base	1	254	121255	SCREW, countersunk, 6-32 x 0.38	2
220■	289696	MODULE, fluid control	1	255†	16A539	BOX, junction box	1
222*		BRACKET, mounting, bottom	1	256	C31012	CLAMP	1
223*		BRACKET, mounting	1	257	110637	SCREW, mach, pan head	4
				258		BRACKET, mount	1
				259☛		O-RING	1
				260☛		CONNECTOR, power, female, 3 pin	1

Ref.	Part	Description	Qty.	
261	☉	COVER, connector	1	★ Not shown.
262	▲	15J075 LABEL, warning	1	▲ Replacement Danger and Warning labels, tags, and cards are available at no cost.
263	★▲	15H668 LABEL, warning	1	
264		RAIL, din, assy	1	* Standard only on tandem supply systems.
265		BUSHING, strain relief; M40 thread	1	☼ Kits 24D009, 24D010, 24K670, and 24K671.
266		NUT, strain relief; M40 thread	1	‡ Parts included in Low or Empty Sensor Kit 255469 (purchase separately).
267	24B810	CONNECTOR, bulkhead, 15 pin	1	
268	113970	SCREW, cap, sch	4	✖ Parts included in Drum Low and Empty Sensor Kit 24C530 (purchase separately).
269	C19208	WASHER, lock	4	
270	102794	NUT, hex	4	* Parts included in 3 in. Ram Bracket Mounting Kit 24C628 (purchase separately).
271		COVER, junction box	1	
272	111640	WASHER, lock, internal	4	
273	100166	NUT, full hex	4	
274	16A355	WIRE, ground	1	‡ Parts included in Pump Heater Kit 24C495 (purchase separately).
276	▲	196548 LABEL, caution	1	
277	★	114958 STRAP, tie	7	◆ Parts included in Stainless Steel Pump Heater Kit 24K669 (purchase separately).
278	112788	SCREW, cap, sch	4	
279	*‡✖	BRACKET, sensor, low/empty	1	✓ Parts only available in Display Mounting Kit 24C653 (purchase separately).
280	*‡✖	122716 SENSOR, inductive, M12	2	
281	*‡✖	ACTUATOR, sensor, low/empty	1	☉ Parts only available in Cover Connector Kit 256883 (purchase separately).
282	124131	SCREW	2	
283	103181	WASHER, lock	2	
284	16K094	SWITCH, overtemp, horizontal	1	■ Replacement electronic components do not have Warm Melt specific software installed. Therefore, use software upgrade token 25D885 to install software before use.
285	C33037	TAPE, fiberglass	1	
286	106245	SCREW	1	
287	157974	WASHER	1	
288	16K066	CLAMP, support	1	

Heated Platens - 20L, 30L, and 60L

Platen 24D066 (20L) Shown

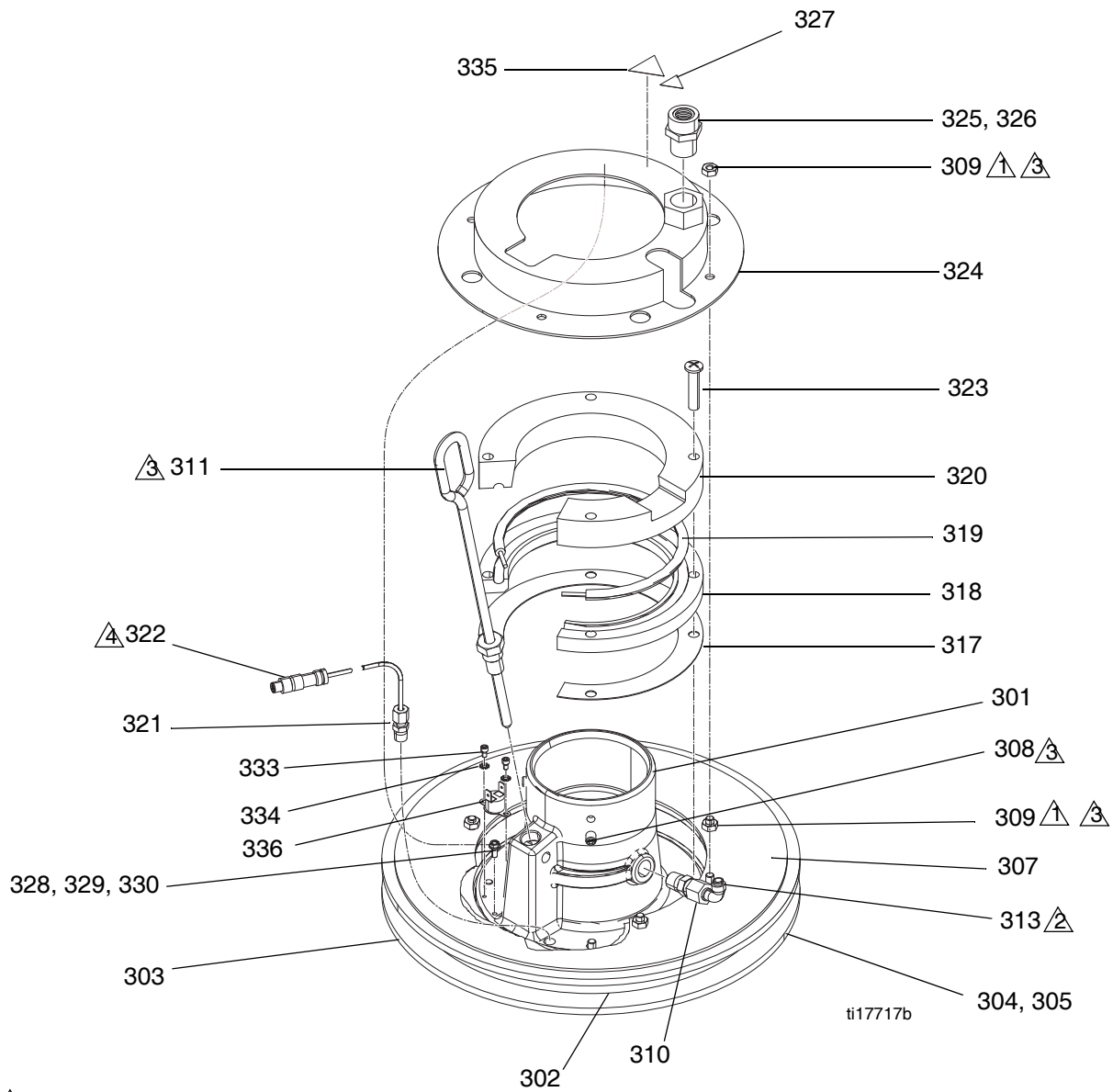

Torque to 45 +/- 5 in-lbs (5.1 +/- 0.6 N•m)

Apply sealant to all non-swiveling pipe threads.

Add lubricant to threads.

Ground RTD sleeve to screw (332).

Parts Used on all Heated Platens

Ref.	Part	Description	Qty.	Ref.	Part	Description	Qty.
				322	16D383	SENSOR, RTD, 1k ohm, shielded	1
301		BASE, platen	1				
305		PLATE, bottom	1	323		NUT, barrel, binding screw	4
306	121829	O-RING	1	324		GUARD, heat shield	1
309		NUT, keps, hex hd	12 or 20	325		COUPLER, conduit	1
311	257697	HANDLE, bleed, sst, assy	1	326		CONDUIT, ID 12.9mm	36
312	109482	O-RING	1	327	189930	LABEL, caution	1
313	C20350	ELBOW, 90 deg.	1	328	C38163	WASHER, lock, external	1
317		GASKET, heat transfer	1	329	100166	NUT, full hex	1
318		PLATE, heater, lower	1	330	16A356	WIRE, ground	1
319		HEATER (includes wiring to switch 336)	1	331	16H441	WIRE, ground	1
320		PLATE, heater, upper	1	332	111593	SCREW, grounding	1
321		HOLDER, RTD sensor	1	335	15K616	LABEL, safety	1
				336	15B137	SWITCH, thermal	1
				337	104714	SCREW, machine	
				338	103181	WASHER, lock	

▲ Replacement Danger and Warning labels, tags, and cards are available at no cost.

Parts that Vary by Heated Platen Model

Ref.	Description	Heated Platen Models						Qty
		24D066, 20L Platen, CS	24D067, 30L Platen, CS	24D068, 60L Platen, CS	24D069, 20L Platen, SST	24D070, 30L Platen, SST	24D071, 60L Platen, SST	
302	SPACER, dual wiper	257694	257695	257696	262873	262874	257684	1
303	WIPER, main	257678	257679	257680	257675	257676	257677	2
304	WIPER, support	257681	257682	257683	257681	257682	257683	1
307	PLATE, top	257686	257687	257688	257698	257699	257725	1
308	SCREW, set, sch	100421	100421	100421	109477	109477	109477	2
310	VALVE, check	122056	122056	122056	501867	501867	501867	1
333	WIPER, support	---	---	---	15V442	15V443	15V444	1
334	SPACER, nylon, 3/4 in.	---	---	---	16J835	16J835	16J835	1

Electrical Enclosure Parts

257158 for single supply systems and ram A of tandem supply systems

257291 for ram B of tandem supply systems

257158 Shown

Side View

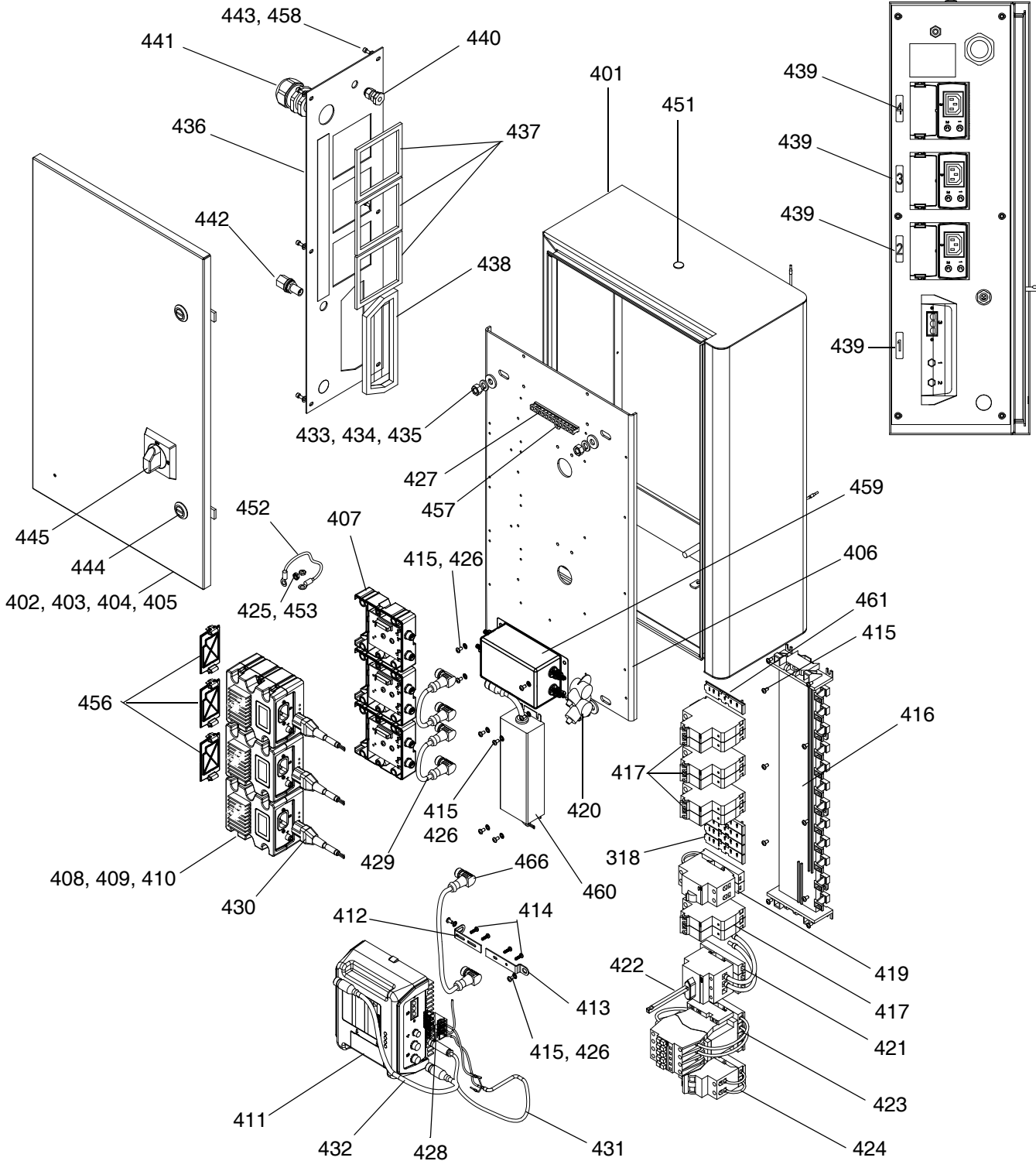

Electrical Enclosure Parts

Ref.	Part	Description	Qty	Ref.	Part	Description	Qty
			.	458	112905	WASHER, plain	6
401		ENCLOSURE	1	459★	123373	FILTER, power line; single phase	1
402		DOOR, enclosure	1	460★	123374	SUPPLY, power; 24Vdc, 2.5A, 60W	1
403	101682	SCREW, cap, sch	4			(included in only 257158)	
404	100016	WASHER, lock	4	461		COVER, buss bar, single	1
405	100015	NUT, hex, mscr	4	466	125789	CABLE, CAN, female/female	1
406	15X754	BRACKET, mounting, electrical	1	467	123615	TERMINAL, bus bar, L3 (257291 only)	1
407★	289697	MODULE, cube, base	3				
408■★	256270	MODULE, low power temp	3				
409	114417	SCREW, self tap, pan hd	12				
410	121070	SCREW, machine, pan hd	3	★	<i>Not shown.</i>		
411■★	255774	MODULE, high power temp	1	▲	<i>Replacement Danger and Warning labels, tags, and cards are available at no cost.</i>		
412	15U651	BRACKET, high power temp module	1	■	<i>Replacement electronic components do not have Warm Melt specific software installed. Therefore, use software upgrade token 16C027 to install software before use.</i>		
413	15R535	BRACKET, mounting, high power temp module	1				
414	117831	SCREW, machine, pan hd	4				
415	100035	SCREW, machine, pan hd	20				
416★	122148	BAR, buss, smissline; 17.125 in.	1				
417★	122619	CIRCUIT, breaker, smissline; 10A (257291 includes qty. of 3)	4				
418	122129	COVER, buss bar	1				
419★	122128	CIRCUIT, breaker	1				
420★	16A573	WIRE, power	2				
421★	122122	SWITCH, disconnect	1				
422	122317	ROD, connecting, on/off	1				
423★	122125	RELAY, contactor	1				
424★	123141	CIRCUIT, breaker, smissline; 25A	1				
425	111640	WASHER, lock, internal	2				
426	157021	WASHER, lock, internal	10				
427★		KIT, bar, ground	1				
428	257341	HARNESS, wiring, high power temp module	1				
429★	121597	CABLE, CAN, 90 female/90 female	2				
430★	15V999	CABLE; 14 in.	3				
431★		CABLE; M8, male/ferrules	1				
432★	121000	CABLE, CAN, female/female; 0.5 m	1				
433	100023	WASHER, flat	4				
434	100133	WASHER, lock	4				
435	100307	NUT, hex	4				
436		PANEL, side, 3 low power heat modules, 1 hp	1				
437		GASKET, low power heat module	3				
438		GASKET, high power heat module	1				
439		LABEL, junction box	1				
440		CORD, grip; PG-7	1				
441		GRIP, cord	1				
442★	121612	CONNECTOR, thru; M12, m x f	1				
443	112788	SCREW, cap, socket hd	6				
444		LATCH, quarter turn	2				
445	15W905	HANDLE, selector, on/off	1				
451		SEAL, hole, plug; 0.5 in.	1				
452	16H441	WIRE, grounding, door	1				
453	100166	NUT, full hex	2				
454	123507	WIRE, ground	1				
456	277674	ENCLOSURE, cube door	3				
457	186620	LABEL, ground	1				

Accessories

Platen Cover, 255691

Two platen covers. See manual 406681 for more information for D200 platens.

Two-Zone Expansion Kit, 24C223

For adding two zones of heat to a Warm Melt Supply System. The two extra zones are controlled through the Warm Melt display.

Two-Zone Accessory Kit, 24C222

Controls two zones of heat; up to 212°F (100°C).

Four-Zone Accessory Kit, 24C526

Controls four zones of heat; up to 212°F (100°C).

Light Tower Accessory Kit, 255468

For use with Warm Melt or Tandem Supply Systems.

Low and Empty Sensor Kit, 24C530

Indicates when the drum is low and empty. Includes two sensors: one to be used as a low sensor, and one to be used as an empty sensor. For use with Warm Melt (to add a low sensor), Ambient, and Tandem supply systems.

Appendix A - User Interface Display

Display Overview

The user interface display is divided into two main functions: Setup mode and Run mode.

Setup Mode Functions

The setup mode functions enable users to:

- set and change the password;
- configure system parameters;
- set heat zone parameters;
- schedule maintenance parameters;
- configure system hardware settings;
- set and change display units and format for all other screens;
- set pump size and drum fill volume;
- and view software information for each system component.

Run Mode Functions

The run mode functions enable users to:

- view current flow rate and drum volume;
- view temperature for heat zones;
- view system job totals and grand totals, and reset totals;
- view current pressures;
- view and reset maintenance counters;
- view and clear individual alarms;
- and view the alarm log.

Display Details

Power Up Screen

The following screen appears when the display module is powered up. It remains on while the display module runs through initialization and establishes communication with other components in the system.



FIG. 59: Power Up Screen

Menu Bar

The menu bar appears at the top of the screen, and consists of the following components.



FIG. 60: Menu Bar

Date and Time

The date and time are always displayed in one of the following formats. The time is always displayed as a 24-hour clock.

- DD/MM/YY HH:MM
- MM/DD/YY HH:MM

Navigation

The navigation section, which is to the right of the date and time, indicates the active screen with the center, highlighted icon. The left and right arrows indicate there are more screens that can be accessed within a mode.

Status



The current system status is displayed on the right of the menu bar. If there is an error, an event icon and either a text description of the event or the standard error code for the event is displayed. If there are no errors or deviations, nothing is displayed.

Mode

The mode section displays the current system mode. The current mode is highlighted.

Error



The current system error is displayed in the menu bar. There are four possibilities:

Icon	Function
No Icon	No information or no error has occurred
	Advisory
	Deviation
	Alarm

Soft Keys

Icons above the soft keys indicate which mode or action is associated with each soft key. Soft keys that do not have an icon above them are not active in the current screen.



Jump In/Jump Out



In screens that have editable fields, press  to access the fields and make changes. When changes are complete press  to exit edit mode.



Navigation within Screens



Press  to open drop-down menus on Setup

screens. Also, press  to enter changes or make a selection.

Press   to navigate to new screens and to navigate left and right within a screen. Also press

  select digits within a field to change.

Press   to navigate to new screens and to navigate up and down within a screen. Also press

  to move between fields within a drop-down menu, and to increment or decrement numbers within a field.

Setup Mode Screens

Setup mode screens are divided into six sections: password, system setup, heat zone setup, maintenance setup, hardware setup, and advanced setup.





Password Screen

While in Run mode, press the Setup  button. If the password is not set to 0000, the Password screen will appear. Enter the password to continue to Setup mode.

NOTE: Upon the first system startup, the System Setup screen will display. Otherwise, the last setup screen viewed will display.

Set Password

To set the password, press  to enter the screen.

Press   to select digit to change. Press   to set value for each digit. Press  again to enter the password.

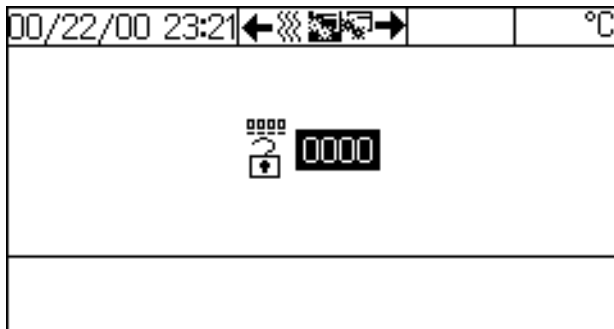







FIG. 61: Password Screen

System Setup

The System Setup screen enables users to configure system settings for the ram(s). Press  to access the fields and make changes. Press  to exit edit mode.

Icon	Function
	Select tandem operation, ram A only operation, or ram B only operation.
	Select if a Not Primed event will issue an alarm or deviation.
	Set number of minutes (1-9) for priming.
	Set pump cycles per minute that will issue a pump runaway alarm. Set between 0 and 99; default setting is 60 cycles; 00 setting disables this function.

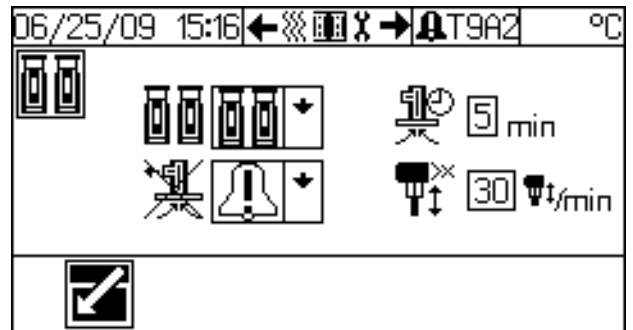















FIG. 62: System Setup

Heater System Setup Screen

This screen enables users to set parameters for each heat zone. Press   to scroll through each heat zone. When the desired heat zone displays, press  to access the fields to make changes. Press  to exit edit mode.

NOTE: Must exit edit mode to scroll through the heat zones.

Icon	Function
A1 	Displays selected heat zone. Press   to scroll through each heat zone.
	Set the temperature setpoint for each heat zone.
	Set the number of degrees the setpoint will be decreased by when the heat zone is in setback mode.
	Set the number of degrees the heat zone can go above the setpoint before an alarm is issued.
	Set the number of degrees the heat zone can go above the setpoint before a deviation is issued.
	Select to enable the heat zone; leave blank to disable the heat zone.
	Shared zone. Select to enable zone for both ram A and ram B.

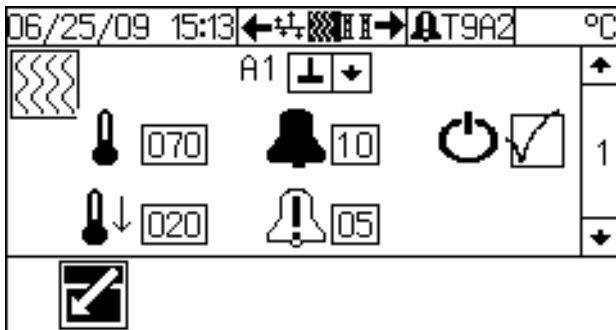



FIG. 63: Heater System Setup Screen

Maintenance Setup Screen

The Maintenance Setup screen enables users to set maintenance intervals for rebuilding platen seals and rebuilding the pump.

Icon	Function
	Set the number of drums (0-9999) between platen seal maintenance. Setting the number of pump cycles to 0 disables this function. If using a tandem system, set for each ram. A rebuild platen seals error is issued when maintenance is required. See Alarm Codes and Troubleshooting on page 37.
	Set the number of pump cycles (0-9999) between pump maintenance. Setting the number of pump cycles to 0 disables this function. If using a tandem system, set for each pump. A rebuild pump error is issued when maintenance is required. See Alarm Codes and Troubleshooting on page 37.

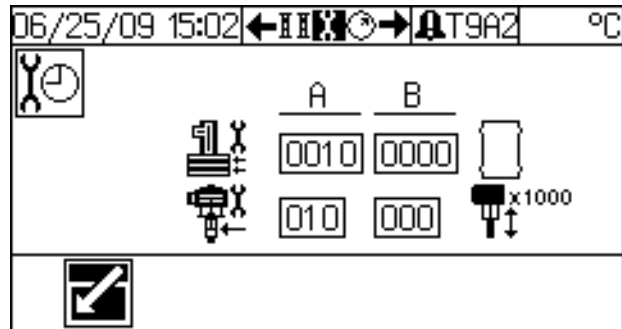





FIG. 64: Maintenance Setup

Hardware Setup Screens





The Hardware Setup screens enable users to specify if specific hardware is installed on the system and to

adjust hardware settings. Press   to scroll through the Hardware Setup screens. Once in the desired Hardware Setup screen, press  to access the fields to make changes. Press  to exit edit mode.

NOTE: Must exit edit mode to scroll through the Hardware Setup screens.

Hardware Setup Screen 1

This screen enables users to specify if a fluid filter monitor is installed, and set the high and low limits for the pressure drop across the filter.

Icon	Function
	Select what type of error will be issued if filter pressure drops below the low limit or raises above the high limit. Select  to disable filter monitoring or if there is no filter installed on the system.
	Set low limit (0-1000 psi) for pressure drop that will issue an error. Set the low limit to detect a filter element collapse or a missing element.
	Set high limit (0-5000 psi) for pressure drop that will issue an error. Set the high limit to detect a clogged filter.

Monitor the filter pressure readings through the normal range of flow with a clean filter to establish the initial limit settings.

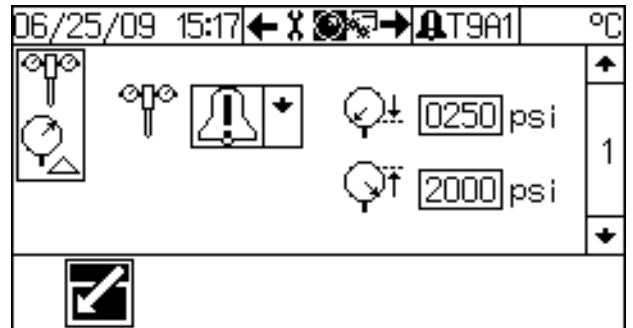



Fig. 65: Hardware Setup Screen 1 (Filter)

Hardware Setup Screen 2

This screen enables users to specify if a fluid solenoid is installed, and if a drum low sensor is installed. The fluid solenoid controls the depressurize/recirculate valve.

Icon	Function
	Select if fluid solenoid is installed on system. Set for A and B rams.
	Select if drum low sensor is installed on system. Set for A and B rams.

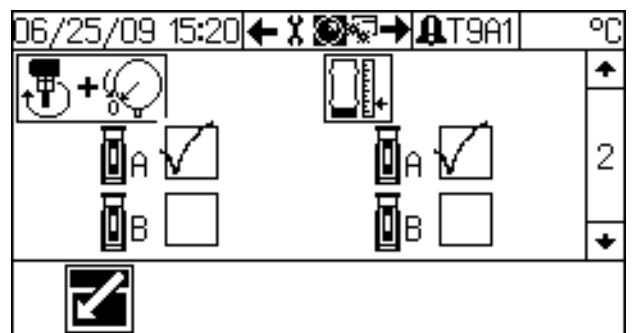





Fig. 66: Hardware Setup Screen 2



Advanced Setup Screens





The Advanced Setup screens enable users to set units, adjust values, set formats, and view software information for each component. Press   to scroll through the Advanced Setup screens. Once in the desired Advanced Setup screen, press  to access the fields to make changes. Press  to exit edit mode.

NOTE: Must exit edit mode to scroll through the Advanced Setup screens.

Advanced Setup Screen 1

This screen enables users to set units that display on other screens.

NOTE: On two-zone and four-zone enclosure accessory kit, only  and  settings are available.

Icon	Function
	Select units of measurement for volume. Select between cycles/gal. gal., oz., and liters/cc.
	Set units of measurement for maintenance intervals. Select between cycles, drums, gal., and liters.
	Set units of measurement for pressure. Select between psi and bar.
	Set the password. Use digits 0-9999; 0000 = no password.
	Set units of measurement for temperature. Select between °F and °C.

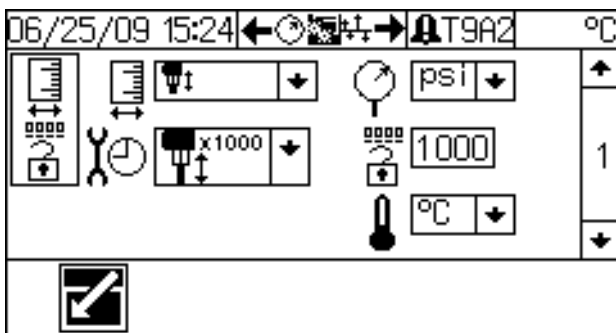

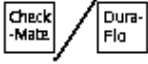

FIG. 67: Advanced Setup Screen 1

Advanced Setup Screen 2

This screen enables users to set the pump size (in cc/cycle) and the drum fill volume (in volume units). The drum fill volume is the amount of material in a new drum, which is used to calculate the volume of material remaining during operation.

NOTE: These values must be entered accurately for the volume remaining estimates on the Ram Operation screen to be accurate.

Icon	Function
	Set pump size (cc/cycle) for each ram. Check-Mate: Select between 60, 100, 200, 250, and 500. Dura-Flo: Select between 145, 180, 220, 290, 430, 580, and 1000.
	Set fill volume for each drum. Use digits 1-9999.
	Change between a Check-Mate or Dura-Flo pump.

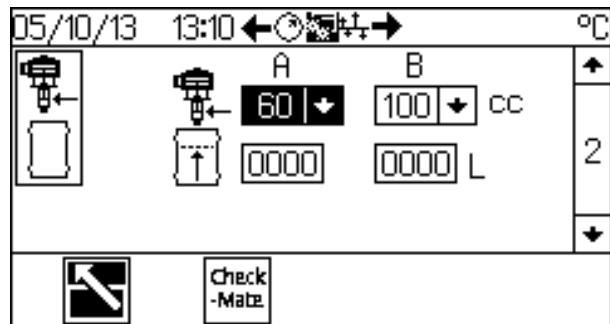





FIG. 68: Advanced Setup Screen 2

Advanced Setup Screen 3

This screen enables users to set the date, time, and date format.

Icon	Function
	Set date format. Select between MM-DD-YYYY and DD-MM-YYYY.
	Set current date.
	Set current time.

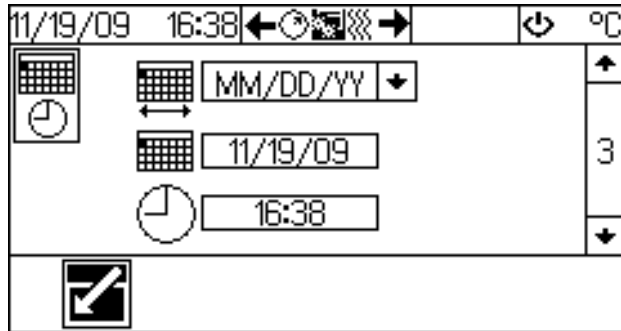





FIG. 69: Advanced Setup Screen 3

Advanced Setup Screens 4 and 5

These screens display the software part number and version information for the system components. Only system components that are detected via the system data bus will be displayed on these screens.

Icon	Function
	Controller software part number and version.
	Display software part number and version.
	Fieldbus gateway software part number and version.
	Temperature controller software part number and version.

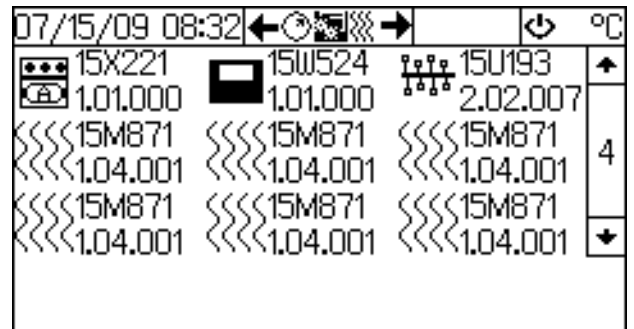



FIG. 70: Advanced Setup Screens 4 and 5

Run Mode Screens

Run mode screens are divided into six sections: ram operation, heat zone operation, current system status, preventative maintenance schedule, current alarms, and error reports. The system starts in Run mode. If the system is in Setup mode, press  to enter Run mode.

Ram Operation Screen

The Ram Operation screen displays which ram (A or B) is active, and how much volume remains in each drum. This screen also displays the flow rate of the active ram. When the fluid line is shown filled the system is on.

Depending on the current system status, users can perform the following procedures from the Ram Operation screen:

- turn the air motor on and off;
- depressurize and pressurize the system;
- recirculate fluid within the active ram;
- prime the pump(s);
- and perform a manual crossover on tandem systems.

See **Operation**, page 29, for instructions on all of these procedures.

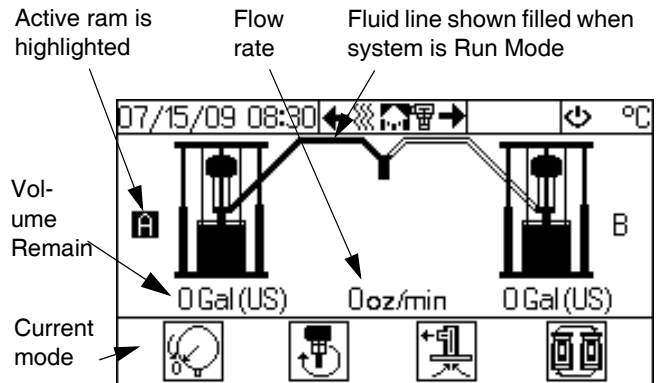





FIG. 71: Ram Operation Screen - Tandem System

The Ram Operation screen will display the appropriate icon and highlight the corresponding soft key if the system is:

- depressurized ,
- in Recirculate mode ,
- or if a ram is in Prime mode .

Heat Run Screen

The Heat Run screen displays information for four to six heat zones. See FIG. 72 for information about each zone. For each zone, the icon on the upper right is present if the zone is enabled, otherwise the space is blank. The temperature unit is shown in the upper right of the menu bar. An alarm icon displays in the bottom right if there is an alarm or deviation on a heat zone. Press the soft key under the alarm icon to clear the alarm or deviation.

NOTE: Heat zones five and six are located in the two-zone expansion kit.

Heat zones seven through ten are located on Ram B. Heat zones eleven and twelve are located in the two-zone expansion kit.

The last digit in the temperature control module alarm codes represents the zone reporting the alarm.

Zone Number	Temperature Control Module Alarm Code
A1	1
A2	2
A3	3
A4	4
A5	5
A6	6
B1	7
B2	8
B3	9
B4	10
B5	11
B6	12

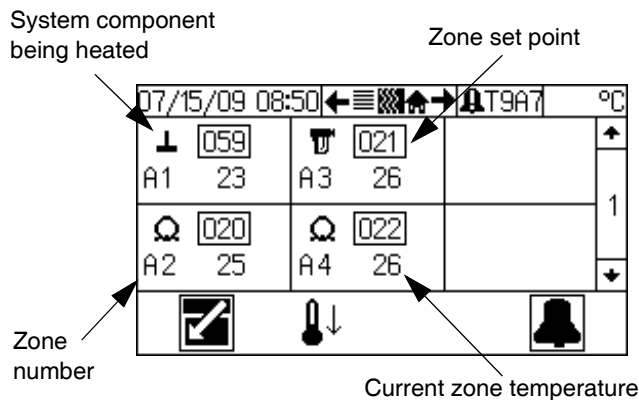



FIG. 72: Heat Run Screen - Ram A

From the Heat Run screen, users can view heat zone information for each ram, put heat zones into Setback mode, turn heaters on and off for enabled heat zones, and change the individual zone temperature settings.

View Heat Zone Information

To view heat zone information, press   to scroll through the Heat Run screens.

NOTE: Must exit edit mode to scroll through the Heat Run screens.



Setback Mode

To put heaters into setback mode for enabled heat zones, press . The setpoint for each zone will be decreased by the setback amount set on **Heater System Setup Screen**, page 96.



Turn On Heaters





See **System Heat Up**, page 27, for instructions.

Change Zone Temperature Setting

Press  to access the fields to make changes. Use the navigation buttons to move to the desired heat zone. Enter the new temperature and press  to save the change. Press  to exit edit mode.

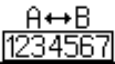
Status Screen

This screen displays the job totals and grand totals. If there is a filter or an error issued, there will be a second screen. Press   to scroll through the Status screens.

Icon	Function
	Job total column; indicates pump cycle count total for a single job.
	Grand total column; indicates pump cycle count total for all jobs.
	Displays pump cycle count for Ram A for a single job and all jobs.
	Displays pump cycle count for Ram B for a single job and all jobs.
	Displays pump cycle count for entire system for a single job and all jobs.

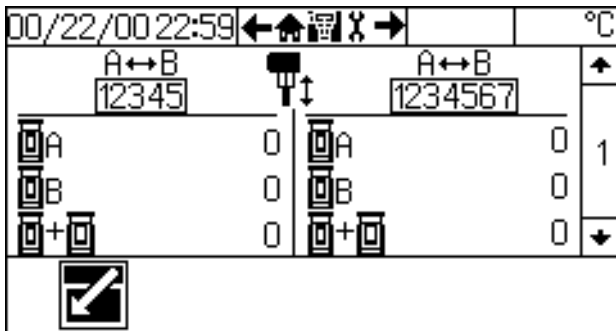





FIG. 73: Status Screen 1





To reset a job total for a single ram (A or B), press  to access the fields, navigate to the value, and press . When prompted, press  to confirm. If the job total is reset, A and B totals will also be reset. Press  to exit edit mode.

NOTE: Grand totals cannot be reset.

Maintenance Screen

The maintenance screen enables operators to establish a preventive maintenance schedule based on the system application and repair history. This screen displays the number of maintenance units remaining before preventive maintenance is due for the platen seals and pump.

NOTE: If a maintenance interval is set to 0, the display will be a series of dashes.

Icon	Function
	Current count remaining until platen requires maintenance. Platen maintenance is reported in drums  .
	Current count remaining until pump requires maintenance. Pump maintenance is reported in units set by the maintenance unit control  in the Advanced Setup screen 1. The example shown in FIG. 74 is set to units of 1000 pump cycles  ^{x1000} .

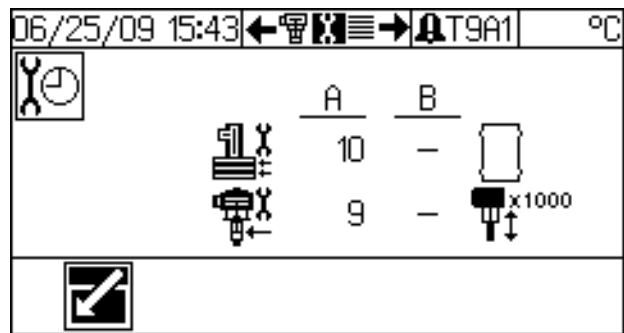











FIG. 74: Maintenance Screen

To reset a counter, press  to access the fields, navigate to the value, and press . When prompted, press  to confirm. Press  to exit edit mode.

Alarm Screen

The alarm screens display the type of alarm currently occurring on each ram. Once an alarm is resolved, use this screen to clear the alarm.

NOTE: For more information regarding alarms. See Alarms on page 37.

Icon	Alarm Code	Function
	B61X B62X	Crossover Error A crossover to a pump with an error was attempted.
	DA1X DA2X	Pump Runaway Pump is running faster than the runaway limit.
	DB1X DB2X	Pump Not Primed A new drum has not been primed.
	DK1X KD2X	Air Motor Sensor Error Air motor sensor detects a fault in the pump motion.
	DD1X DD2X	Pump Diving Pump leak or ram air pressure is too low.
	L11X L12X	Drum Empty Drum for ram A or ram B is empty.

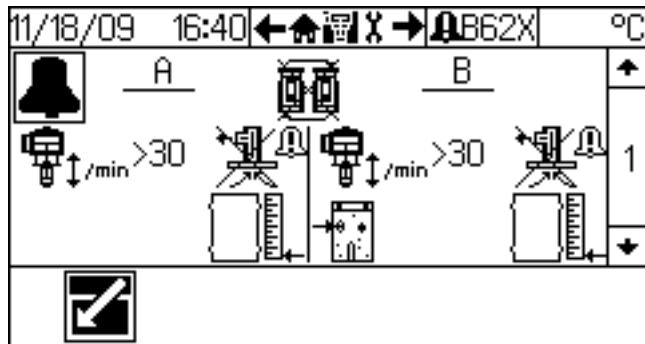











FIG. 75: Ram Alarm Screen

To clear an alarm, press  to access the fields, navigate to the alarm icon, and press . When prompted, press  to confirm. Press  to exit edit mode.

Report Screens

The five Report screens display a chronological list of the most recent 20 errors. See **Alarm Codes and Troubleshooting**, page 37, for details regarding each alarm code.

Icon	Function
#	Chronological order of errors as they occur.
	Date when error occurred.
	Time when error occurred.
	Error code.

Press   to scroll through the five report screens.

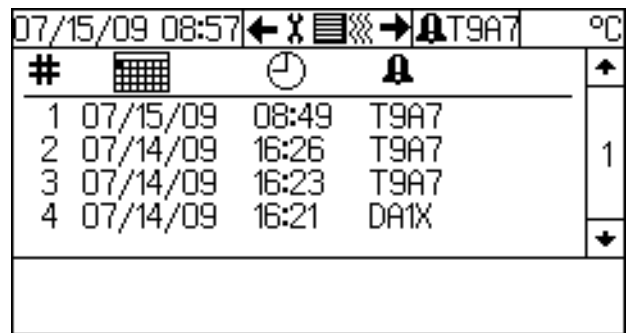
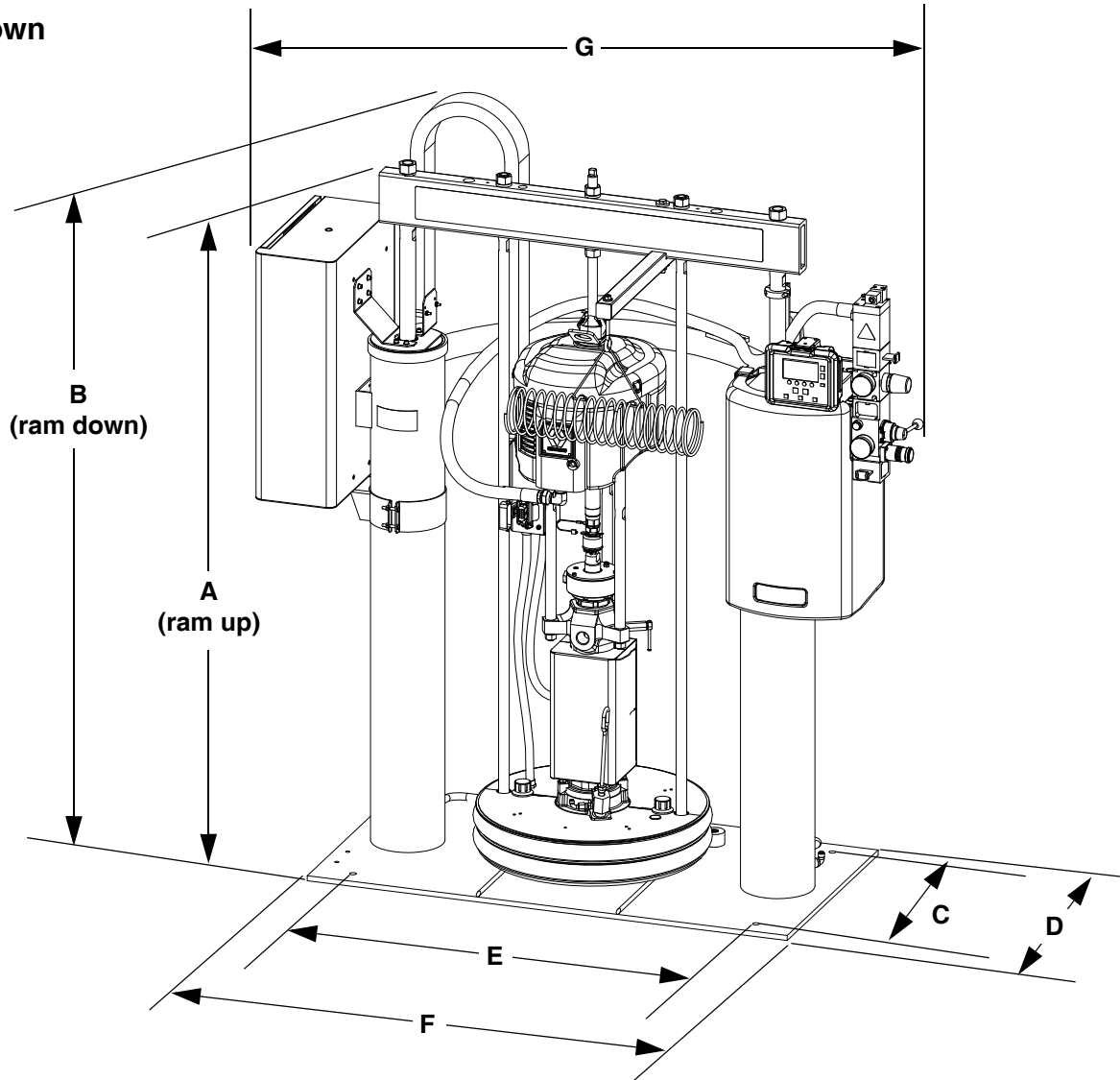

FIG. 76: Report Screen

Dimensions

D200 Models

D200s Shown



Ram Model	A in. (mm)	B in. (mm)	C in. (mm)	D in. (mm)	E in. (mm)	F in. (mm)	G in. (mm)
D200	102.3 (2599)	72.6 (1844)	21.0 (533)	25.0 (635)	38.0 (965)	42.0 (1067)	56.4 (1433)
D200s	104.9 (2665)	74.3 (1887)	23.0 (584)	25.0 (635)	45.0 (1143)	48.0 (1219)	64.6 (1641)

D60 Models

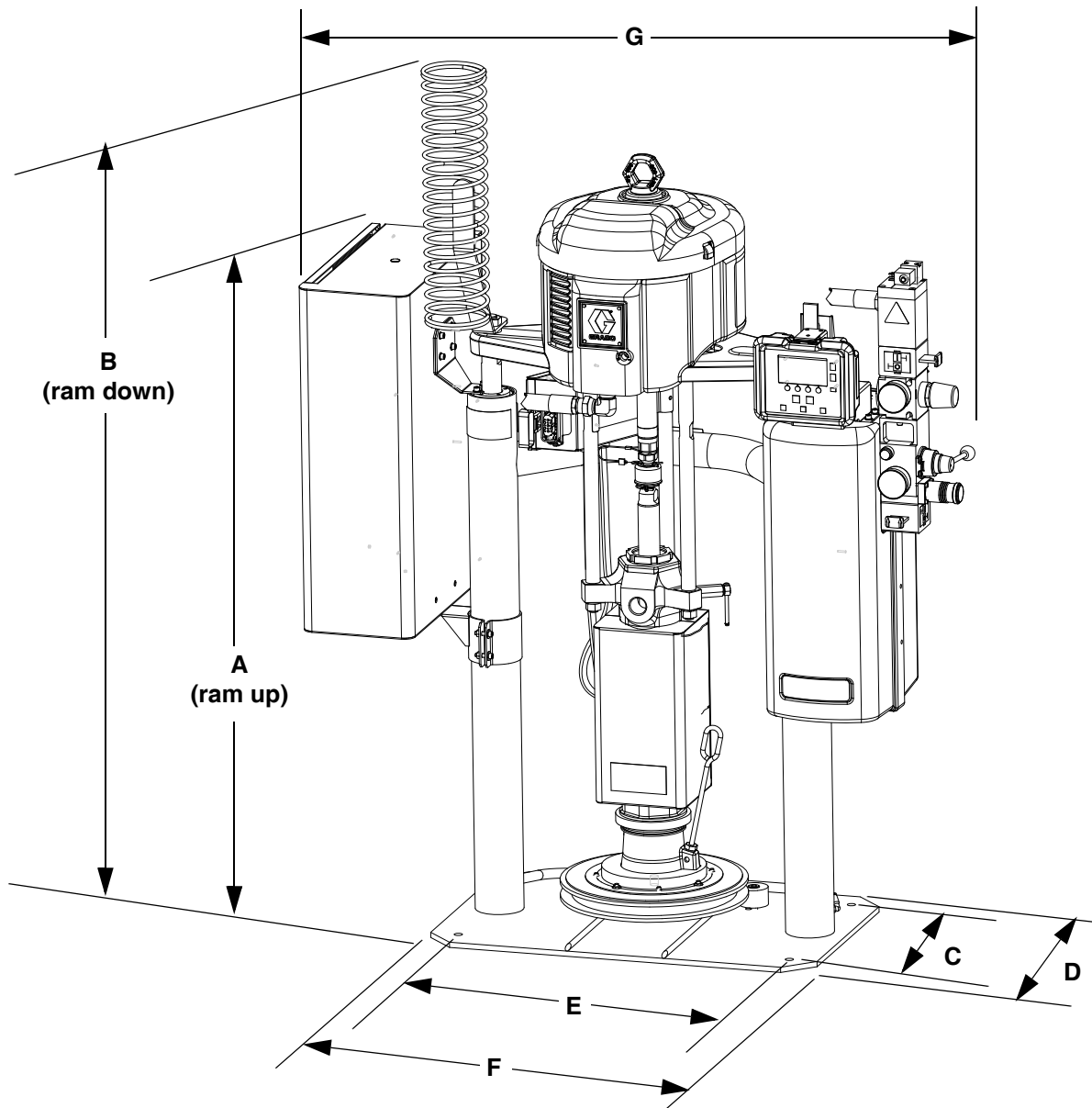

Ram Model	A in. (mm)	B in. (mm)	C in. (mm)	D in. (mm)	E in. (mm)	F in. (mm)	G in. (mm)
D60	92.7 (2355)	62.7 (1593)	14.0 (356)	18.0 (457)	24.0 (610)	28.0 (711)	47.0 (1194)

Technical Data

Max air input pressure (supply system)

D60 - 3 in. dual post, 5 gal. (20 L), 16 gal. (60 L), 30 gal. (115 L)	150 psi (1.0 MPa, 10 bar)
D200 - 3 in. dual post, 55 gal. (200 L)	150 psi (1.0 MPa, 10 bar)
D200s - 6.5 in. dual post, 55 gal. (200 L)	125 psi (0.9 MPa, 9 bar)

Max fluid and air working pressure

See table below.

Wetted parts and weight (displacement pump)

See Check-Mate Displacement Pump manual 312375.

Platen Codes (see page 4): Part number; Wetted parts

F: 257729, 5 gal. (20 L)	Stainless steel, polyurethane, PTFE coated nitrile, polyethylene, nitrile, PTFE, 303 sst, 304 sst, 316 sst, 17-4PH sst
L: 257734, 8 gal. (30 L)	
U: 257738, 16 gal. (60 L)	
H: 257731, 5 gal. (20 L)	Electroless nickel, aramind reinforced elastomer, rubber-based PSA, polyurethane, polyethylene, nitrile, zinc plated carbon steel, buna, 1018 carbon steel, 304 sst, 316 sst, 17-4PH sst
R: 257736, 8 gal. (30 L)	
Y: 257741, 16 gal. (60 L)	
8: 255662, 55 gal. (200 L)	PTFE, EPDM, PTFE coated aluminum, zinc plated carbon steel, 316 sst
9: 255663, 55 gal. (200 L)	EPDM, aluminum, zinc plated carbon steel, 316 sst

Maximum operating temperature (supply system)

158°F (70°C)

Sound data

See NXT Air Motor manual 311238.

External power supply requirements

AC power units

220-250 Vac, 50/60 Hz, single phase, 57 amps full load current

Maximum Fluid Working Pressure and Flow Rate at Full Air Pressure (100 psi)

Ratio	Maximum Air Inlet Pressure psi (MPa, bar)	Maximum Fluid Working Pressure psi (MPa, bar)	Motor	Displacement Pump (cc per cycle)	Flow Rate gpm (lpm)	
					30 cpm	60 cpm
23	100 (0.7, 7.0)	2300 (16.1, 161)	NXT2200	200	1.6 (6.0)	3.2 (12.0)
36	100 (0.7, 7.0)	3600 (25.2, 252)	NXT3400	200	1.6 (6.0)	3.2 (12.0)
68	91 (0.64, 6.4)	6200 (43.4, 434)	NXT6500	200	1.6 (6.0)	3.2 (12.0)

Weight

See the identification plate (ID) for the weight of your supply system.

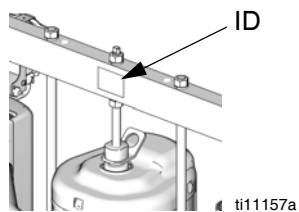

Graco Standard Warranty

Graco warrants all equipment referenced in this document which is manufactured by Graco and bearing its name to be free from defects in material and workmanship on the date of sale to the original purchaser for use. With the exception of any special, extended, or limited warranty published by Graco, Graco will, for a period of twelve months from the date of sale, repair or replace any part of the equipment determined by Graco to be defective. This warranty applies only when the equipment is installed, operated and maintained in accordance with Graco's written recommendations.

This warranty does not cover, and Graco shall not be liable for general wear and tear, or any malfunction, damage or wear caused by faulty installation, misapplication, abrasion, corrosion, inadequate or improper maintenance, negligence, accident, tampering, or substitution of non-Graco component parts. Nor shall Graco be liable for malfunction, damage or wear caused by the incompatibility of Graco equipment with structures, accessories, equipment or materials not supplied by Graco, or the improper design, manufacture, installation, operation or maintenance of structures, accessories, equipment or materials not supplied by Graco.

This warranty is conditioned upon the prepaid return of the equipment claimed to be defective to an authorized Graco distributor for verification of the claimed defect. If the claimed defect is verified, Graco will repair or replace free of charge any defective parts. The equipment will be returned to the original purchaser transportation prepaid. If inspection of the equipment does not disclose any defect in material or workmanship, repairs will be made at a reasonable charge, which charges may include the costs of parts, labor, and transportation.

THIS WARRANTY IS EXCLUSIVE, AND IS IN LIEU OF ANY OTHER WARRANTIES, EXPRESS OR IMPLIED, INCLUDING BUT NOT LIMITED TO WARRANTY OF MERCHANTABILITY OR WARRANTY OF FITNESS FOR A PARTICULAR PURPOSE.

Graco's sole obligation and buyer's sole remedy for any breach of warranty shall be as set forth above. The buyer agrees that no other remedy (including, but not limited to, incidental or consequential damages for lost profits, lost sales, injury to person or property, or any other incidental or consequential loss) shall be available. Any action for breach of warranty must be brought within two (2) years of the date of sale.

GRACO MAKES NO WARRANTY, AND DISCLAIMS ALL IMPLIED WARRANTIES OF MERCHANTABILITY AND FITNESS FOR A PARTICULAR PURPOSE, IN CONNECTION WITH ACCESSORIES, EQUIPMENT, MATERIALS OR COMPONENTS SOLD BUT NOT MANUFACTURED BY GRACO. These items sold, but not manufactured by Graco (such as electric motors, switches, hose, etc.), are subject to the warranty, if any, of their manufacturer. Graco will provide purchaser with reasonable assistance in making any claim for breach of these warranties.

In no event will Graco be liable for indirect, incidental, special or consequential damages resulting from Graco supplying equipment hereunder, or the furnishing, performance, or use of any products or other goods sold hereto, whether due to a breach of contract, breach of warranty, the negligence of Graco, or otherwise.

FOR GRACO CANADA CUSTOMERS

The Parties acknowledge that they have required that the present document, as well as all documents, notices and legal proceedings entered into, given or instituted pursuant hereto or relating directly or indirectly hereto, be drawn up in English. Les parties reconnaissent avoir convenu que la rédaction du présente document sera en Anglais, ainsi que tous documents, avis et procédures judiciaires exécutés, donnés ou intentés, à la suite de ou en rapport, directement ou indirectement, avec les procédures concernées.

Graco Information

For the latest information about Graco products, visit www.graco.com.

For patent information, see www.graco.com/patents.

TO PLACE AN ORDER, contact your Graco distributor or call to identify the nearest distributor.

Phone: 612-623-6921 or Toll Free: 1-800-328-0211 Fax: 612-378-3505

*All written and visual data contained in this document reflects the latest product information available at the time of publication.
Graco reserves the right to make changes at any time without notice.*

Original instructions. This manual contains English. MM 313296

Graco Headquarters: Minneapolis

International Offices: Belgium, China, Japan, Korea

GRACO INC. AND SUBSIDIARIES • P.O. BOX 1441 • MINNEAPOLIS MN 55440-1441 • USA

Copyright 2009, Graco Inc. All Graco manufacturing locations are registered to ISO 9001.

www.graco.com

Revision N, October 2019