

333511A

Mobile Lubrication Library



# Caterpillar D10 Dozer

**Suggested automated lubrication system layout for a Caterpillar D10 Dozer.**

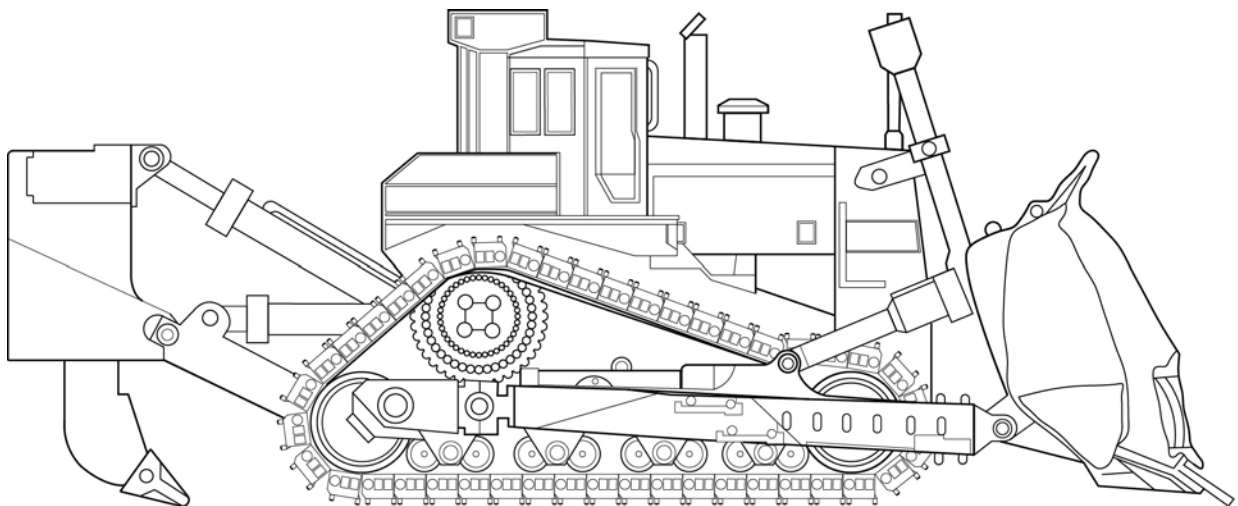

### Important Safety Information

Read all warnings and instructions in all related manuals. Save all instructions.



Fluid leaks from incorrectly installed or ruptured components, and/or failure to verify the components are properly installed and tested, can result in serious injury such as fluid spraying in the eyes or on skin and fluid injection, or equipment damage.

To prevent injury or equipment damage, installation must be done by a professional and tested prior to use. Consult Parker literature for specific hose assembly instructions. These instructions are available from your Parker representative or at [www.Parker.com/pdf](http://www.Parker.com/pdf).

### Related Manuals

Manual No.	Manual Title
3A0414	G3 Pump
312349	60# / 90# DynaStar 10:1 Pump
308955	90# Fireball 50:1 Pump
313855	GLC-4400 Controller
308953	GL-1 Injectors
3A0528	Remote Manual Run
312497	MSP Divider Valves
307273	Fluid Outlet Filter

*The information contained in this document is only a recommendation for an automatic lubrication system and is not intended to replace the installation and maintenance instructions provided by the original equipment manufacturer.*

# Suggested Lube Points

## GL-1 Injectors

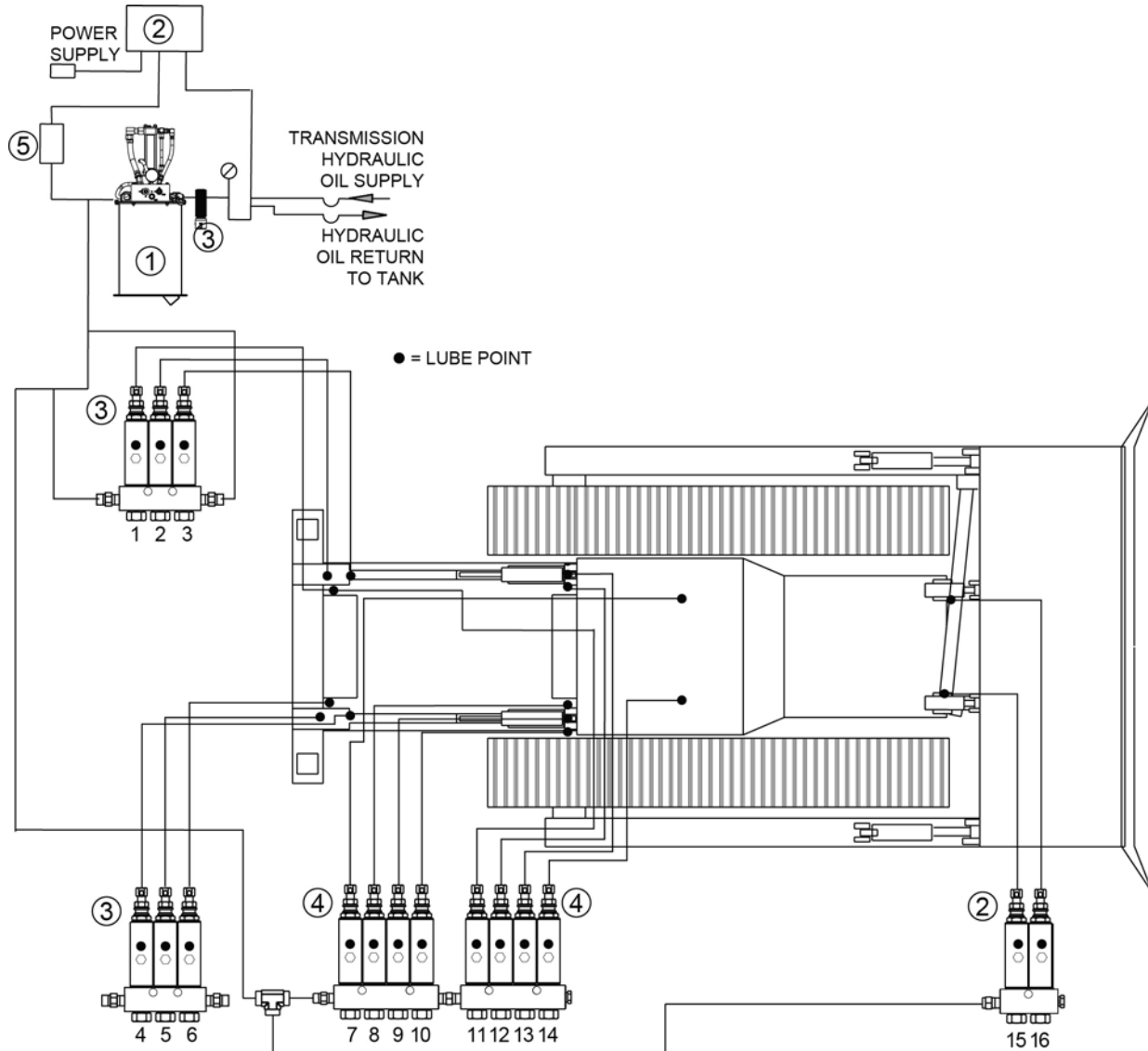

GL-1 Injector Parts List			
SEQ #	Part No.	Description	Qty
1	247444	90# DynaStar 10:1 Pump	1
	247574	60# DynaStar 10:1 Pump	1
	241573	90# Fireball 50:1 Pump	1
	TBD	Electric Pump	1
2	24B591	GLC-4400 Controller DC	1
3	214570	Fluid Filter	1
4	114904	Injector, GL1, 2 Point	4
5	115124	Pressure Switch	1

# MSP Divider Valves

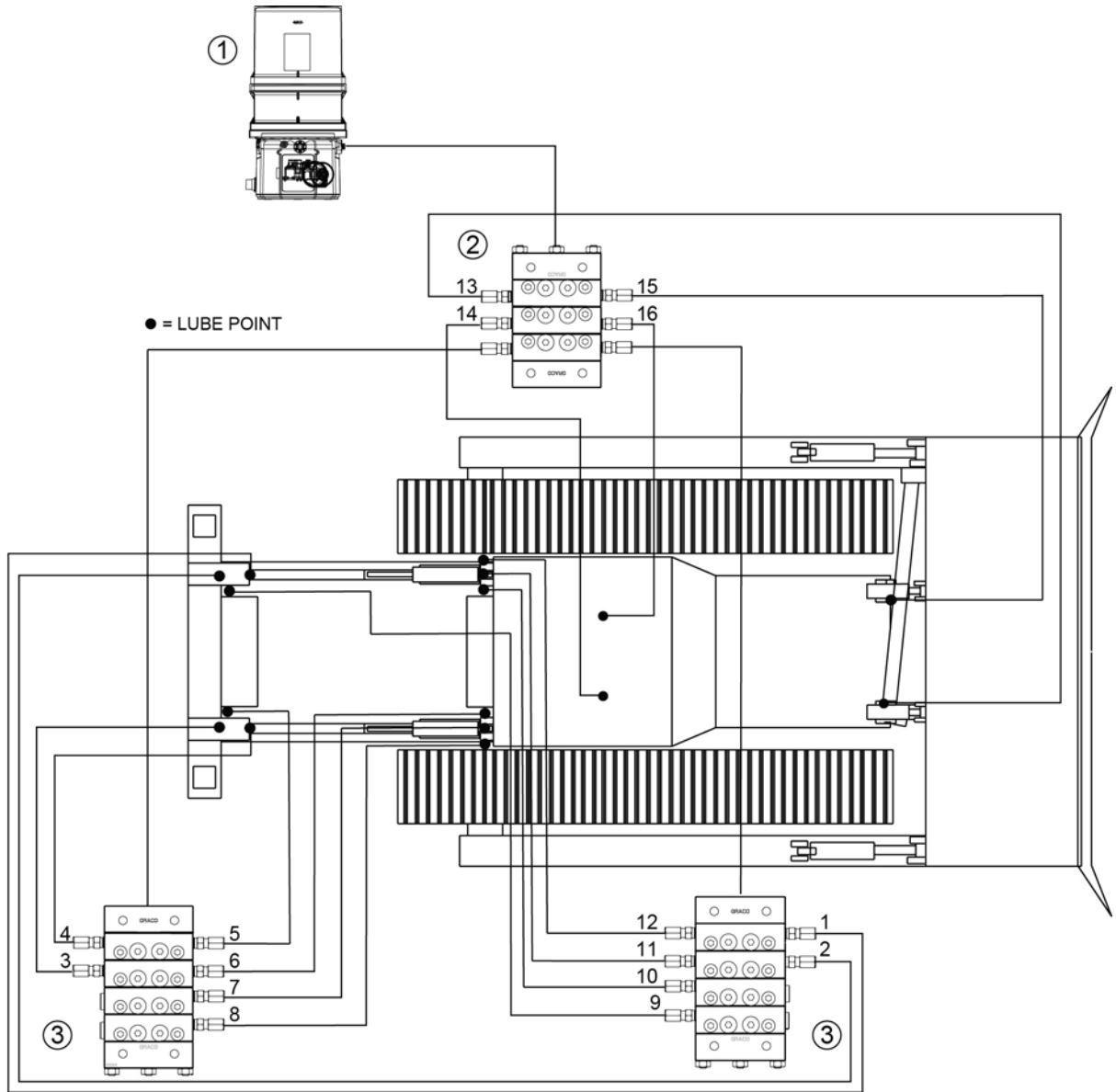

## MSP Divider Valve Parts List

SEQ #	Part No.	Description	Qty
1	96GXXX	G3 Pump	1
2		MSP Divider Valve - 3 (T,T,T)	1
3		MSP Divider Valve - 4 (T,T,S,S)	

## Lube Point Information

<b>Lube Points</b>				
<b>Lube Point</b>	<b>Lube Point Location</b>	<b>GL-1 Volume</b>	<b>GL-1 Turns</b>	<b>MSP Volume cu. in.</b>
1	Blade lift cylinder support yoke			
2	Blade lift cylinder support yoke			
3	Blade lift cylinder support yoke			
4	Blade lift cylinder support yoke			
5	Ripper tilt cylinder rod end pin			
6	Ripper arm pin			
7	Ripper tilt cylinder rod end pin			
8	Ripper arm pin			
9	Ripper tilt cylinder bottom pin			
10	Ripper tilt cylinder bottom pin			
11	Ripper tilt cylinder bottom pin			
12	Ripper tilt cylinder bottom pin			
13	Ripper arm pin			
14	Ripper tilt cylinder rod end pin			
15	Ripper arm pin			
16	Ripper tilt cylinder rod end pin			

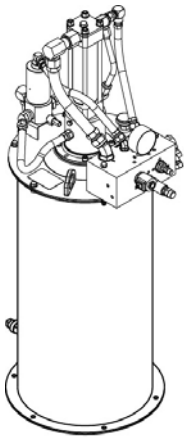

90# DynaStar Pump\*

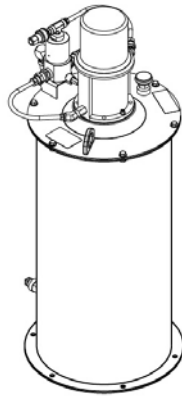

50:1 Fireball Pump\*

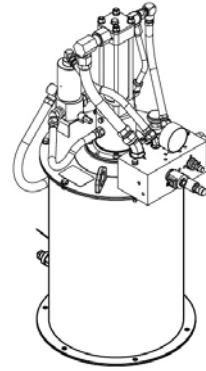

60# DynaStar Pump\*

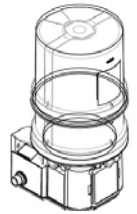

G3 Pump\*

\*See related pump instruction manual for Technical Data

GL-1 Injector Parts		
Part No.	Description	
556284	Hose, 0.25 in. ID SAE100R7	Supply to injector
556773	End, hose, SAE #4 JIC	Supply to injector
C20479	Nipple, 1/4 NPT(m)	Injector in/out
555808	Plug, hex, 1/4 NPT	Injector in/out
556762	Connector, 3/4 x 1/4 PM	Injector in/out
556763	Elbow, #4 x 1/4 PM	Bearing point
15K740	Elbow, 1/4 -28(m) x 1/8-24(f)	Bearing point
117029	Mounting screws	Injector

MSP Divider Valve Parts		
Part No.	Description	
556284	Hose, 0.25 in. ID SAE100R7	Supply to valve bank
556773	End, hose, SAE #4 JIC	Supply to valve bank
563251	Cycle indicator, 7/16-20	Valve bank
556644	Connector, 1/8 NPT x 3/16T	Bearing point
557349	Plug, 1/8 NPT(f)	Valve bank
557968	Zerk, 1/8	Valve bank
15K740	Elbow, 1/4-28(m) x 1/8-24(f)	Bearing point
556638	3/16T x 1/8 NPT	Bearing point

# Typical Pump Installation

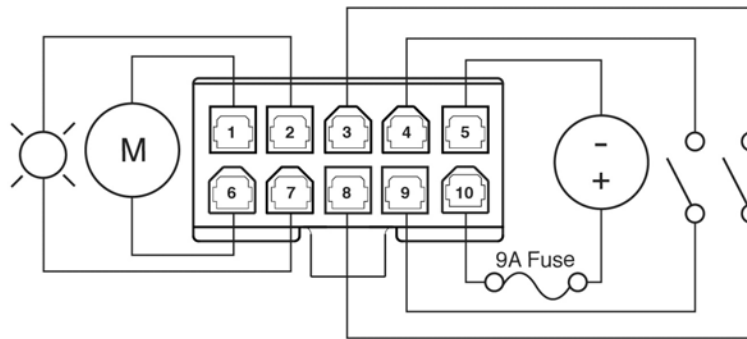
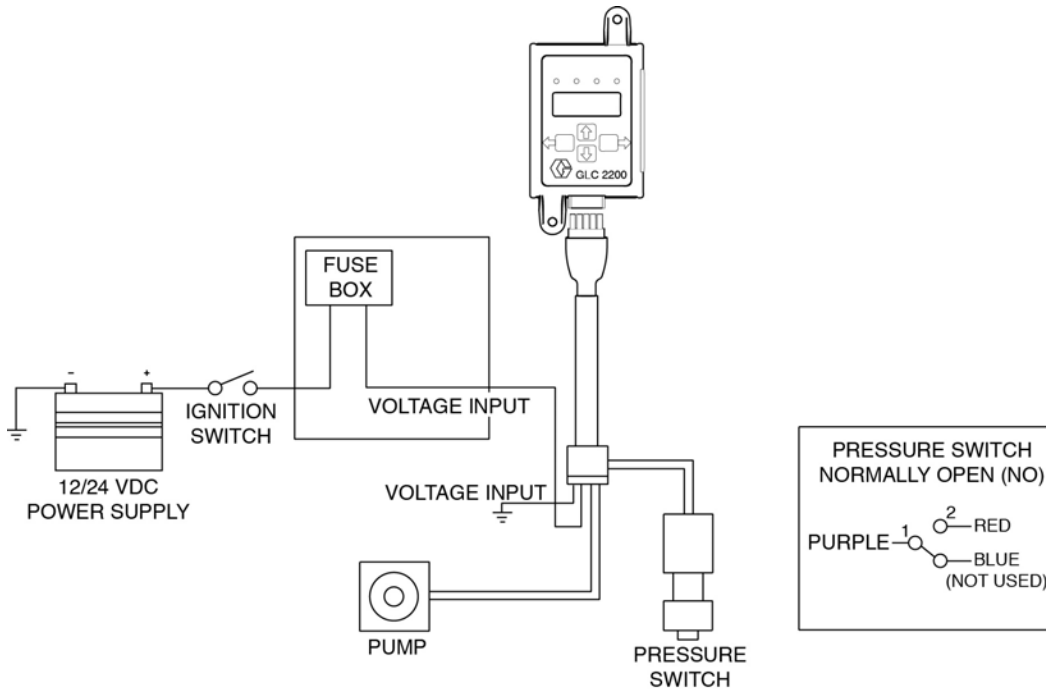

Connector Identification Label

PIN	1	2	3	4	5
	9A	2A			
				P/C	+9V +30V
PIN	6	7	8	9	10

## Graco Information

For the latest information about Graco products, visit [www.graco.com](http://www.graco.com).

**TO PLACE AN ORDER**, contact your Graco distributor or call to identify the nearest distributor.

**Phone:** 612-623-6928 **or Toll Free:** 1-800-533-9655, **Fax:** 612-378-3590