

19:1 LubePro™ Single Stroke Oil Pump with Low Level

3A3232E

EN

For pumping non-corrosive and non-abrasive lubricants only. For professional use only.

Not approved for use in explosive atmospheres or hazardous locations.

Model No. 19C752

*19:1 Oil pump with Low Level, Normally Closed (NC)
Switch, NPT Threads*

Model No. 20C752

*19:1 Oil pump with Low Level, Normally Closed (NC)
Switch, BSPP Adapter*

3500 psi (24 MPa, 241 bar) Maximum Working Pressure



Important Safety Instructions

Read all warnings and instructions in this manual.
Save these instructions.

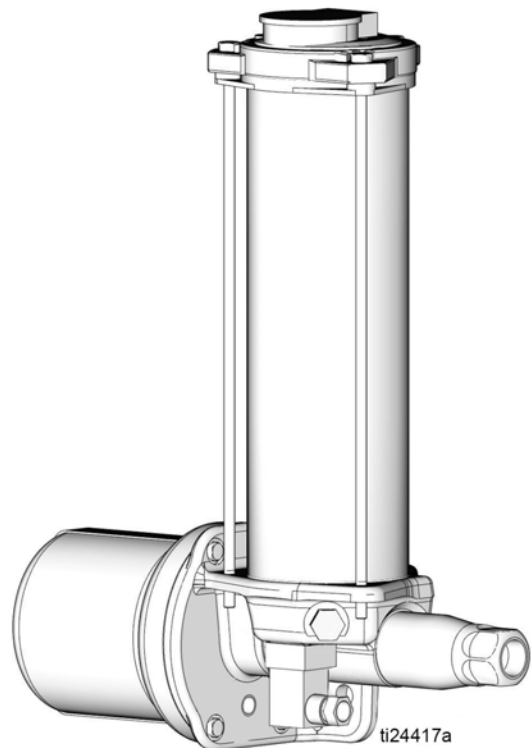











Table of Contents

Warnings	3
Installation	5
Typical Installation	5
Grounding	6
Mounting	6
Air and Fluid Line Accessories	7
Fill Reservoir	7
Priming	8
Pressure Relief Procedure	9
Air Lock Procedure	9
Operation	11
Pump	11
Low Level Switch	11
Shut Down	11
Lubrication System Sizing and Calculation Guidelines	12
Repair	13
Seal Replacement	13
Troubleshooting	27
Parts	28
Dimensions and Mounting	30
Technical Data	31
Graco Standard Warranty	32







Warnings

The following warnings are for the setup, use, grounding, maintenance, and repair of this equipment. The exclamation point symbol alerts you to a general warning and the hazard symbols refer to procedure-specific risks. When these symbols appear in the body of this manual or on warning labels, refer back to these Warnings. Product-specific hazard symbols and warnings not covered in this section may appear throughout the body of this manual where applicable.

 <h1 style="margin: 0;">WARNING</h1>	
  	<p>SKIN INJECTION HAZARD</p> <p>High-pressure fluid from dispensing device, hose leaks, or ruptured components will pierce skin. This may look like just a cut, but it is a serious injury that can result in amputation. Get immediate surgical treatment.</p> <ul style="list-style-type: none"> • Do not point dispensing device at anyone or at any part of the body. • Do not put your hand over the fluid outlet. • Do not stop or deflect leaks with your hand, body, glove, or rag. • Follow the Pressure Relief Procedure when you stop dispensing and before cleaning, checking, or servicing equipment. • Tighten all fluid connections before operating the equipment. • Check hoses and couplings daily. Replace worn or damaged parts immediately.
	<p>PRESSURIZED EQUIPMENT HAZARD</p> <p>Over-pressurization can result in equipment rupture and serious injury.</p> <ul style="list-style-type: none"> • Do not exceed the maximum air input pressure. • Fill slowly to avoid over pressurizing reservoir. • Use tubing, hoses and other components with pressure ratings equal to or higher than the pump rating.
 	<p>PLASTIC PARTS CLEANING SOLVENT HAZARD</p> <p>Many solvents can degrade plastic parts and cause them to fail, which could cause serious injury or property damage.</p> <ul style="list-style-type: none"> • Use only compatible water-based solvents to clean plastic structural or pressure-containing parts. • See Technical Data in this and all other equipment instruction manuals. Read fluid and solvent manufacturer's Safety Data Sheets (SDSs) and recommendations.
 	<p>ELECTRIC SHOCK HAZARD</p> <p>This equipment must be grounded. Improper grounding, setup, or usage of the system can cause electric shock.</p> <ul style="list-style-type: none"> • Turn off and disconnect power at main switch before disconnecting any cables and before servicing or installing equipment. • Connect only to grounded power source. • All electrical wiring must be done by a qualified electrician and comply with all local codes and regulations.



WARNING

 	<p>EQUIPMENT MISUSE HAZARD</p> <p>Misuse can cause death or serious injury.</p> <ul style="list-style-type: none"> • Do not operate the unit when fatigued or under the influence of drugs or alcohol. • Do not exceed the maximum working pressure or temperature rating of the lowest rated system component. See Technical Data in all equipment manuals. • Use fluids and solvents that are compatible with equipment wetted parts. See Technical Data in all equipment manuals. Read fluid and solvent manufacturer's warnings. For complete information about your material, request SDS from distributor or retailer. • Turn off all equipment and follow the Pressure Relief Procedure when equipment is not in use. • Check equipment daily. Repair or replace worn or damaged parts immediately with genuine manufacturer's replacement parts only. • Do not alter or modify equipment. Alterations or modifications may void agency approvals and create safety hazards. • Make sure all equipment is rated and approved for the environment in which you are using it. • Use equipment only for its intended purpose. Call your distributor for information. • Route hoses and cables away from traffic areas, sharp edges, moving parts, and hot surfaces. • Do not kink or over bend hoses or use hoses to pull equipment. • Keep children and animals away from work area. • Comply with all applicable safety regulations.
	<p>TOXIC FLUID OR FUMES HAZARD</p> <p>Toxic fluids or fumes can cause serious injury or death if splashed in the eyes or on skin, inhaled, or swallowed.</p> <ul style="list-style-type: none"> • Read SDSs to know the specific hazards of the fluids you are using. • Store hazardous fluid in approved containers, and dispose of it according to applicable guidelines.
 	<p>MOVING PARTS HAZARD</p> <p>Moving parts can pinch, cut or amputate fingers and other body parts.</p> <ul style="list-style-type: none"> • Keep clear of moving parts. • Do not operate equipment with protective guards or covers removed. • Pressurized equipment can start without warning. Before checking, moving, or servicing equipment, follow the Pressure Relief Procedure and disconnect all power sources.
	<p>PERSONAL PROTECTIVE EQUIPMENT</p> <p>Wear appropriate protective equipment when in the work area to help prevent serious injury, including eye injury, hearing loss, inhalation of toxic fumes, and burns. This protective equipment includes but is not limited to:</p> <ul style="list-style-type: none"> • Protective eyewear, and hearing protection. • Respirators, protective clothing, and gloves as recommended by the fluid and solvent manufacturer.
	<p>CALIFORNIA PROPOSITION 65</p> <p>This product contains a chemical known to the State of California to cause cancer, birth defects or other reproductive harm. Wash hands after handling.</p>

Installation



Typical Installation

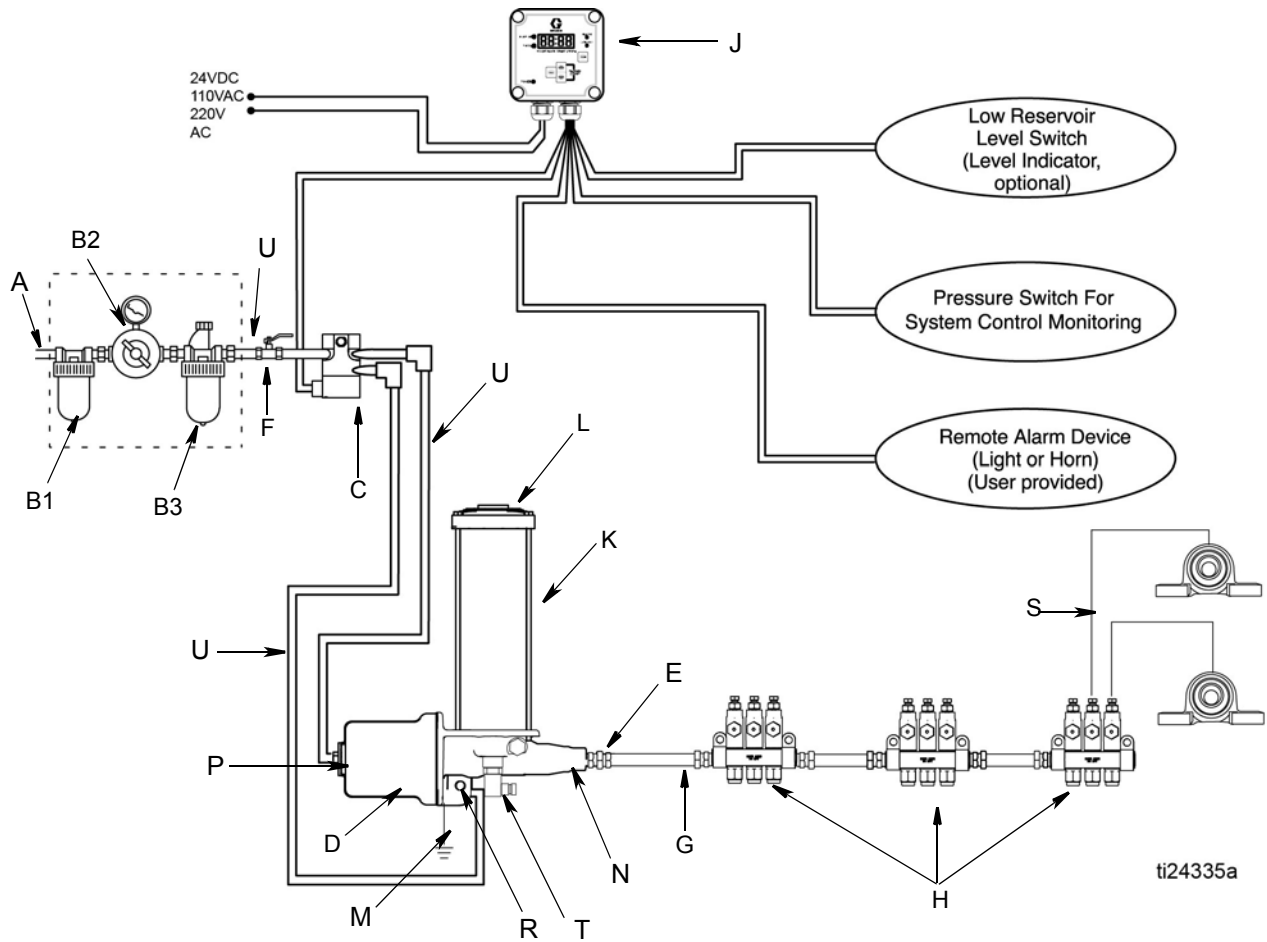

FIG. 1: Typical Installation

Key:

- | | |
|--|-----------------------------------|
| A Main air supply | H Injector |
| B Filter/Regulator/Lubricator Assembly | J Lubricator controller |
| B1 - Air Filter | K Pump reservoir |
| B2 - Air Regulator | L Pump reservoir fill cover |
| B3 - Air Lubricator | M Ground |
| C Air solenoid valve (4-way) | N Pump outlet check body |
| D Pump module | P Pump air inlet - forward stroke |
| E Pump outlet | R Pump air inlet - return stroke |
| F Bleed-type master air valve (required) | S Feeder lines |
| G High pressure lubricant supply lines (user supplied) | T Low level |
| | U Air supply lines |

Grounding



The equipment must be grounded. Improper grounding can cause electric shock. Grounding reduces the risk of electric shock by providing an escape wire for the electric current in the event of malfunction or breakdown.

To ground the pump: Remove the ground screw (Z) located on the back of the pump base and insert it through the eye of the ring terminal (W) at end of ground wire (Y). Fasten the ground screw (Z) back onto the pump and tighten securely. Connect the other end of the ground wire to a true earth ground. See FIG. 2.

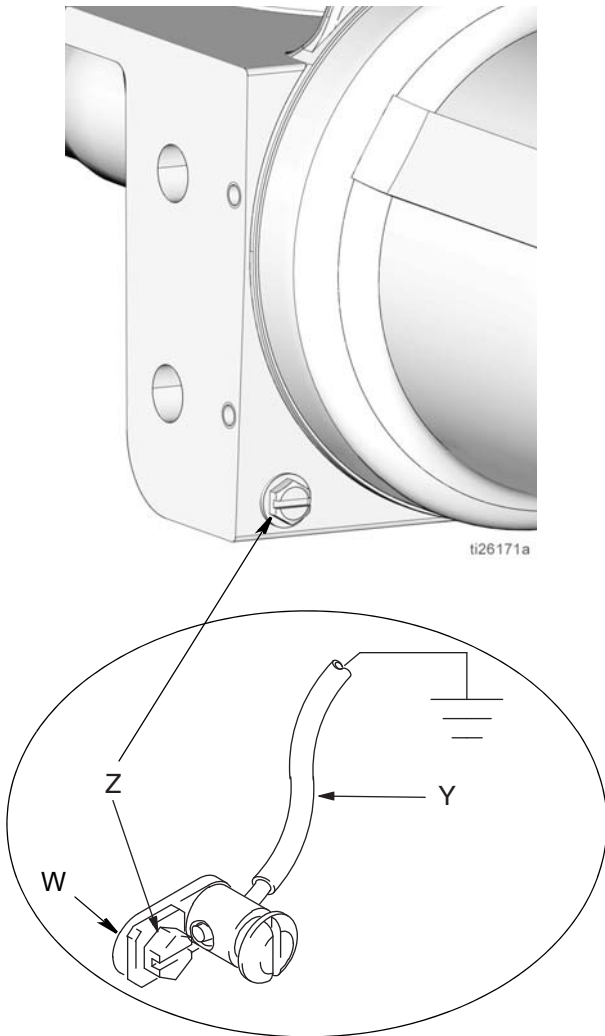

FIG. 2

Mounting



Mount the pump securely so that it cannot move around during operation. Failure to do so could result in injury or equipment damage.

Install the pump in a location that will adequately support the weight of pump when filled with lubricant and also provides easy operator access to the pump air controls. Pump must be mounted in a vertical position with the reservoir up. See Technical Data, page 31 for pump weight information and the Dimensions and Mounting layout, page 30.

Low Level Models Only

DIN Connector

Connection is made to PINS 1 and 2 of the DIN Field Wire-able Connector. See FIG. 3.

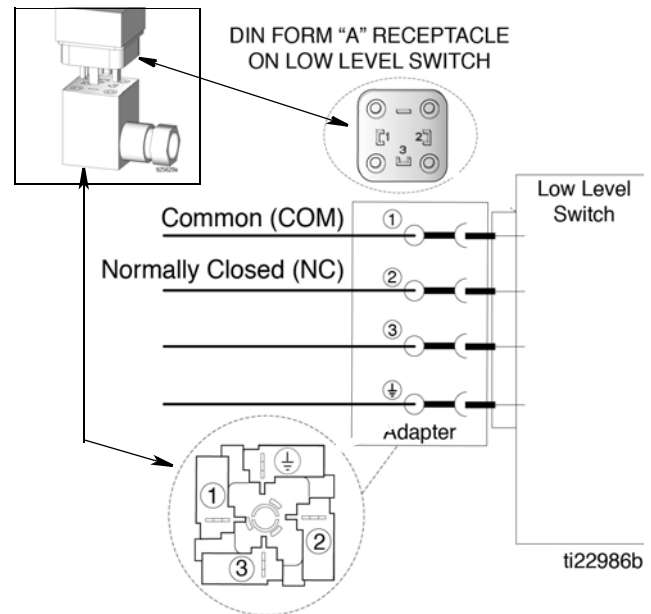





FIG. 3

Air and Fluid Line Accessories

Refer to FIG. 1, page 5, for the following instructions.

Install the air line accessories in the order shown in FIG. 1, page 5.

				
<p>Trapped air can cause the pump to cycle unexpectedly, which could result in serious injury from splashing or moving parts.</p>				



Bleed-type master air valve (F): required in your system to relieve air trapped between it and the pump.

Air line filter (B1): removes harmful dirt and moisture from compressed air supply.

Pump air regulator (B2): to control pump speed and outlet pressure. Locate it close to the pump.

NOTICE
<p>Do not mount the air accessories directly on the solenoid valve air inlet. The air inlet and fittings are not strong enough to support the accessories and may break. Provide a bracket on which to mount the accessories.</p>

1. Install a bleed-type master air valve (F) to relieve air trapped between it and the pump. Install the valve in a location that is easily accessible from the pump and located downstream of the air regulator.
2. Install an air line filter (B1) to remove harmful dirt and contaminants from the compressed air supply
3. Install the air regulator (B2) to control pressure.
4. Install an air line lubricator (B3) to lubricate the air cylinder.
5. Install the (3-way) air solenoid valve (C) for control of the pump forward and return strokes.

				
<p>The maximum working pressure of each component in the system may not be the same. To reduce the risk of over-pressurizing any part of your system, know the maximum working pressure rating of each component and its connected components. Never exceed the maximum working pressure of the lowest rated components connected to a particular pump.</p>				

To use the air regulator reading to determine the fluid output pressure, multiply the ratio of the pump (19:1) by the air pressure shown on the regulator gauge or see Table 1: Lubricant Output - PSI or Table 2: Lubricant Output - MPa (bar), provided on page 12.

Limit the air to the pump so that no air line or fluid line component or accessory is over pressurized.

Air Supply Lines (U)

1. Install two air supply lines (U) between the air solenoid valve outlets (C) and the pump (D) as shown in the Typical Installation, page 5.
2. Install an air supply line (U) between the air solenoid valve inlet (C) and the Filter/Regulator/Lubricator Assembly (B) as shown in the Typical Installation, page 5.

Fill Reservoir

1. Open oil fill cap (oc) located on the top of the reservoir.

NOTE: A strainer (st) is installed at the oil fill cap (oc) to prevent contamination of the lubricant with foreign materials (FIG. 4).

- a. Inspect strainer (st) before filling reservoir.
- b. When needed, remove strainer (st) and clean it thoroughly.
- c. If removed in Step b, install strainer (st) prior to adding lubricant.

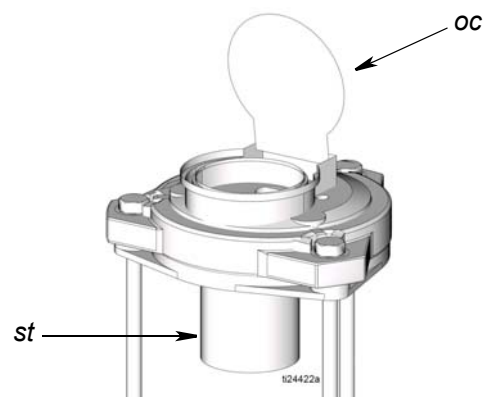

FIG. 4

2. Slowly add oil (*ol*) until reservoir is filled to capacity (FIG. 5). Take care to not fill reservoir too quickly and overflow the reservoir capacity.

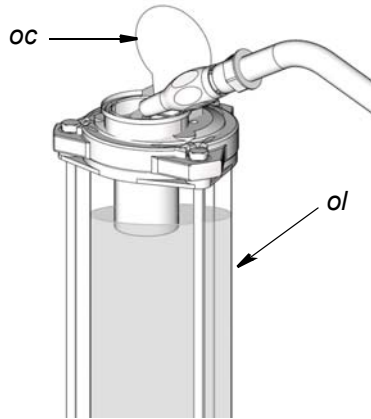

FIG. 5

3. Close oil fill cover (*oc*) to prevent contamination and spillage (FIG. 5).

Priming

NOTE:

- Prime the pump before connecting the outlet to supply line (G).
- Before priming the pump, the reservoir must be filled with lubricant (see Fill Reservoir instructions, page 7).

Run the pump until oil (*ol*), free of air, comes out of the pump outlet (E). See Operation, page 11.

- It may take up to 20 the pump strokes to expel the air from the pump and deliver a continuous flow of oil. This will depend on the viscosity of the lubricant and temperature.
- Allow a minimum of 5 seconds ON time for the forward stroke and 5 seconds OFF time for the return stroke.

Supply Lines

1. Prime the pump until oil (*ol*) comes out of the pump outlet (E). Connect the supply line (G) to the pump outlet (E).
2. If there are multiple pumps on the air line, close the air regulators and bleed-type master air valves to all but one the pumps. If there is only one pump, open its air regulator and bleed-type master air valve.
3. Open the master air valve from the compressor.
4. Set the air pressure to each pump at the lowest pressure needed to get the desired results. See Recommended Pressure provided in **Table 1: Lubricant Output and Pressure - US** or **Table 2: Lubricant Output and Pressure - Metric** provided on page 12.

Feeder Lines (S)

Fill each feeder line (S) with lubricant prior to connecting lines to the injector outlet.

Injectors

1. Check each injector for proper operation. The injector stem should move when lubricant is discharged.
2. Adjust the injector output if needed to ensure that the output volume discharged is sufficient.

Pressure Relief Procedure



Follow the Pressure Relief Procedure whenever you see this symbol.

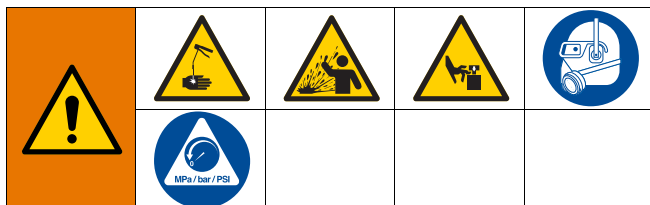

This equipment stays pressurized until pressure is manually relieved. To help prevent serious injury from pressurized fluid, such as skin injection, splashing fluid and moving parts, follow the Pressure Relief Procedure when you stop dispensing and before cleaning, checking, or servicing the equipment.

1. Close the bleed-type master air valve (F, page 5) (required in the system).
2. **Relieve pressure** in system using two wrenches working in opposite directions on the pump outlet (E) and lubrication line fitting (G) to **slowly loosen** the fitting until it is loose and no more lubricant or air is leaking out of the fitting (FIG. 6).

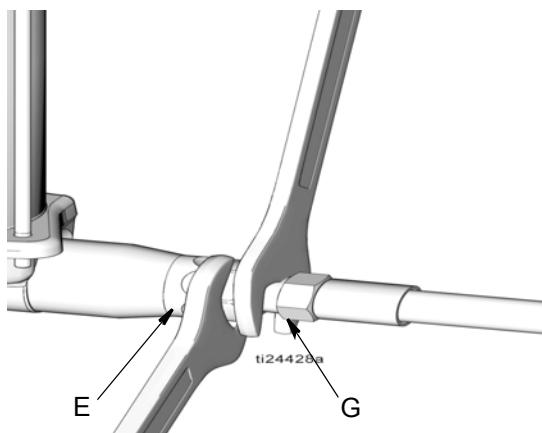

FIG. 6

Air Lock Procedure



The reference letters used in the following instructions, refer to the Typical Installation FIG. 1 on page 5.

An air lock occurs when a bubble or pocket of air prevents the normal flow of the lubricant.

NOTICE

Running the pump dry will cause an air lock. To prevent an air lock, do not run the pump without lubricant. Always refill the pump before it is empty.

If there is an air lock:

1. Refill the reservoir to the full level (page 7).
2. Relieve pressure. See **Pressure Relief Procedure**, page 8.
3. Disconnect the lubricant supply line (G) from the pump outlet (E) (FIG. 7).

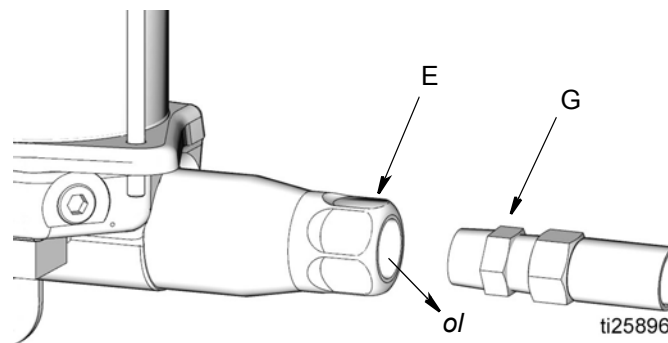

FIG. 7

4. Open the bleed-type master air valve (F, page 5).
5. Run the pump a few strokes until oil (oil), free of air, comes out of the pump outlet (E) (FIG. 7).
 - It may take up to 20 the pump strokes to expel the air from the pump and deliver a continuous flow of oil. This will depend on the viscosity of the lubricant and temperature.
 - Allow a minimum of 5 seconds ON time for the forward stroke and 5 seconds OFF time for the return stroke.

Installation

6. Connect the pump outlet (E) to the lubrication line (G) (FIG. 8).

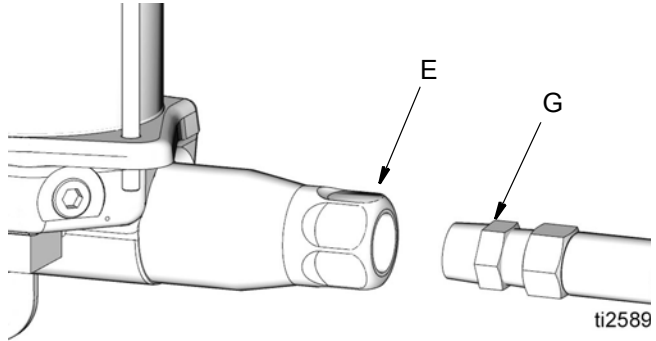

FIG. 8

Operation

Pump

Start Up



1. Verify reservoir is filled with lubricant and system has been Primed (see Prime System, page 8).
2. Turn on the lubrication controller (J) power switch.
3. Program the lubrication controller to actuate the solenoid valve (C).

NOTE: See the lubrication controller instruction manual included with the system for these instructions.

4. Open air regulators and master air valves.

NOTE: Never allow the pump to run dry of the material being the pumped.

NOTICE

Running the pump dry will cause an air lock. To prevent an air lock, do not run the pump without lubricant. Always refill the pump before it is empty.

At the start of a the pump cycle:

- a. The air solenoid (C) supplies air to the pump air inlet (P).
- b. On the pump forward stroke, lubricant is dispensed to all the injectors.
- c. The pump is supplied with air through the air inlet (R).
- d. The pump makes a return stroke, venting the system pressure back to the pump and resetting all of the injector.

Low Level Switch

When the oil reservoir is full, the low level float (*l/f*) sits in the high, raised position as shown in FIG. 9.

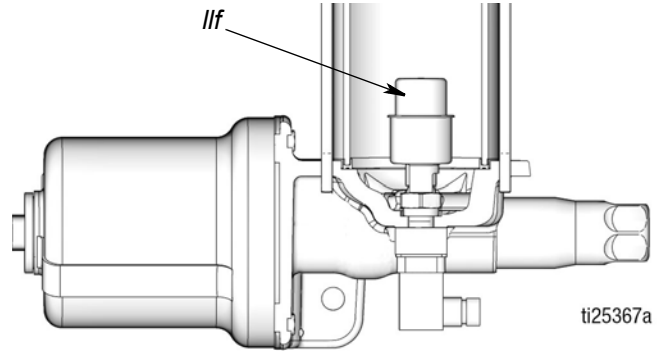

FIG. 9: Low level float in raised position

As oil is dispensed, the low level float begins to travel down. When the oil in the reservoir reaches low level, the fully traveled down float (shown in FIG. 10) opens the normally closed low level switch and a low level signal is sent to the lubricator controller (J).

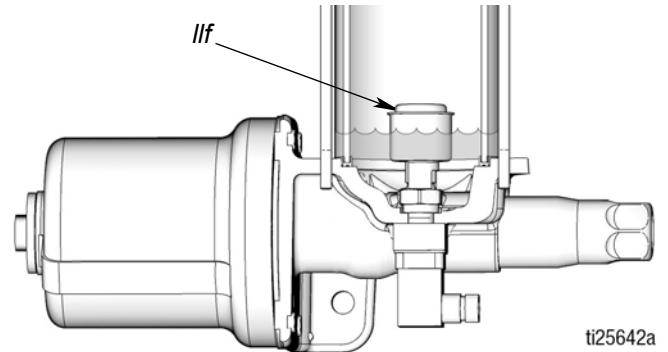

FIG. 10: Low level float in fully traveled down position

Shut Down



To shut down the system:

- a. Close the bleed-type master air valve (F, page 5).
- b. Turn off electrical supply to the lubrication controller (J, page 5).

Lubrication System Sizing and Calculation Guidelines

Table 1: Lubricant Output and Pressure - US

NOTE: The lubricant output per pump stroke must be less than the amount of lubricant discharged per pump stroke.

1	2	3	4	5		6		7	
Injector Type	Max Injector Output cu. in.	Injector Volume to Dispense and Charge cu. in.	Max Pump Lubricant Output / Stroke cu. in.	Maximum Pressure		Minimum Pressure		Recommended Pressure	
				Output PSI	Required Air PSI	Output PSI	Required Air PSI	Output PSI	Required Air PSI
GL-43	0.008	0.016	3.0	1000	53	750	39	850	45
GL42	0.003	0.006							

Table 2: Lubricant Output and Pressure - Metric

1	2	3	4	5		6		7	
Injector Type	Max Injector Output cc	Injector Volume to Dispense and Charge cc	Max Pump Lubricant Output / Stroke cc	Maximum Pressure		Minimum Pressure		Recommended Pressure	
				Output MPA (bar)	Required Air MPA (bar)	Output MPA (bar)	Required Air MPA (bar)	Output MPA (bar)	Required Air MPA (bar)
GL-43	0.131	0.262	49.1	6.9 (68.9)	0.36 (3.6)	5.2 (51.7)	0.26 (2.7)	5.9 (58.6)	0.31 (3.1)
GL42	0.049	0.098							

1. Total Injector Volume to Dispense and Charge
 - a. Add together the total number of injectors in the system.
 - b. From Table 1 or Table 2 above, find your Injector Type in the first column and the related Injector Volume to Dispense and Charge in the third column. Multiply this value by the total number of injectors determined in Step a (above).
2. Calculate the volume of lubricant in the Pipeline (G):
 - a. Use the pipe's inside diameter (ID) measurement to calculate the area of the pipe.
 - b. Measure the length of the pipe (G) only. Do not include the feeder lines (S) in this calculation.
 - c. Multiply the area of the pipe (calculated in Step a) by the length of the pipe (measured in Step b).
3. Calculate line expansion and fluid compression in the pipe using the 10% Rule.
 - a. Multiply the volume calculated in Step 2 by 10%.
4. Calculate the Total System Volume required.
 - a. Add together the total from Step 1, and Step 3 ONLY. Do NOT include Step 2.
 - b. The Total System Volume required must be less than the Pump Lubricant Output / Stroke provided in the fourth column of Table 1 or Table 2.
 - c. If the Total System Volume required is greater than the Pump Lubricant Output / Stroke provided in the fourth column of Table 1 or Table 2, split the system into two or more systems.

Repair

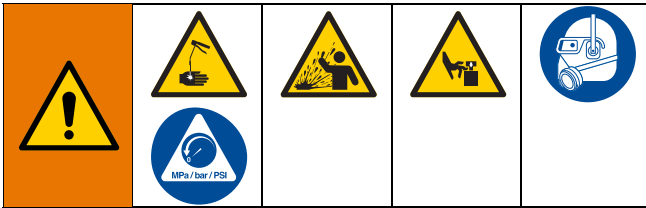

Seal Replacement

NOTE: For most seal replacement procedures, the pump should be completely removed from service and clamped in a vise. If you are only replacing the reservoir and/or reservoir seals, you do not have to remove the pump from its service location. The following instructions cover the complete disassembly of the pump. Your pump repair may not require total pump disassembly.

Disassembly

1. Turn off air supply and disconnect air lines to the pump.
2. Disconnect electrical connections to lubrication controller.
3. Relieve pressure (page 8).
4. Disconnect supply line (G, page 5) from the pump outlet (E, page 5)
5. Remove mounting bolts (FIG. 11) and remove the pump from service.

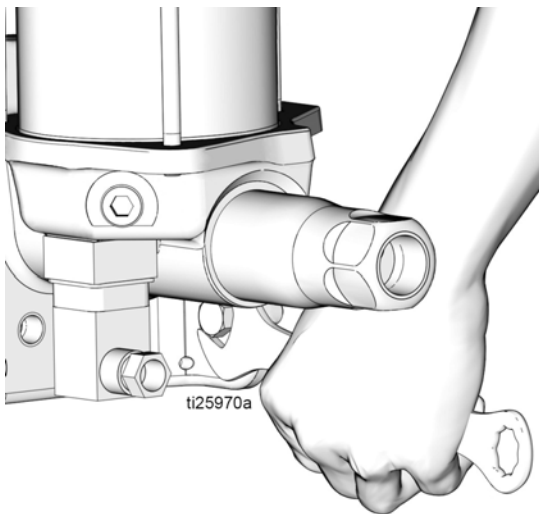

FIG. 11

6. Clamp the pump base in a vise as shown in FIG. 12. Use a soft-jaw vise or place a rag in the vise jaws to protect the surface of the pump base.

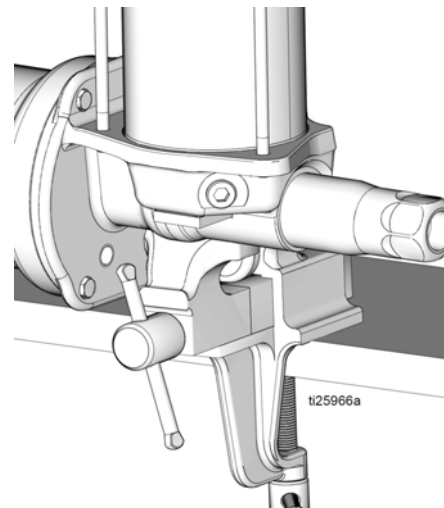

FIG. 12

7. Use a hex wrench to slowly loosen and remove drain plug (34) from the pump base and drain oil from the pump (FIG. 13).

NOTE: Removing the plug slowly will help prevent splashing while the oil drains from the reservoir.

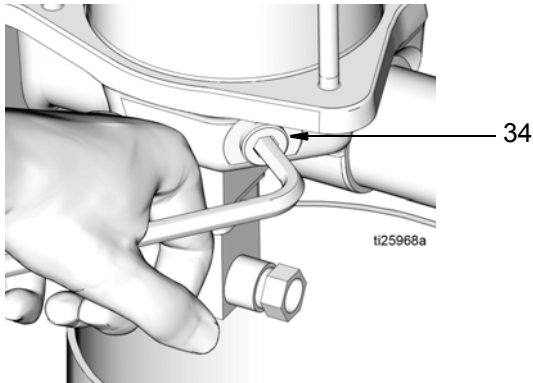

FIG. 13

8. Collect drained oil in a pail or waste container. Dispose of oil according to all regulations for proper disposal.

Replace drain plug (34).

9. Use a wrench to remove tie rods (29). Loosen the rods in a diagonal pattern, taking care to loosen each rod gradually until all rods are completely loosened. Remove tie rods (29) and spacers (20). See FIG. 14.

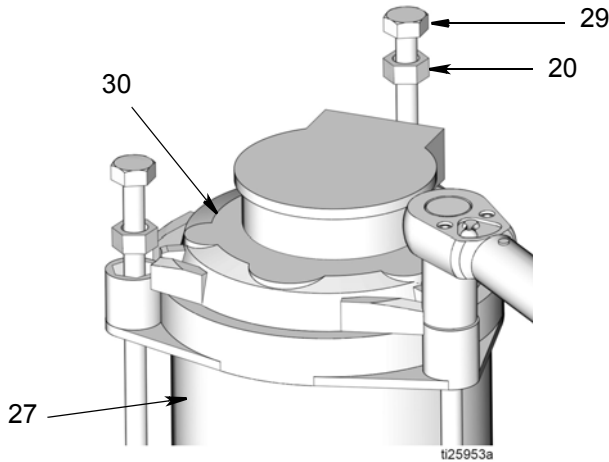

FIG. 14

10. Remove cover (30) from reservoir (27) (FIG. 14).
11. Remove reservoir (27) from the pump base (1) (FIG. 15). If replacing reservoir gaskets (26), remove gaskets from reservoir. Dispose of gaskets according to all regulations for proper disposal.

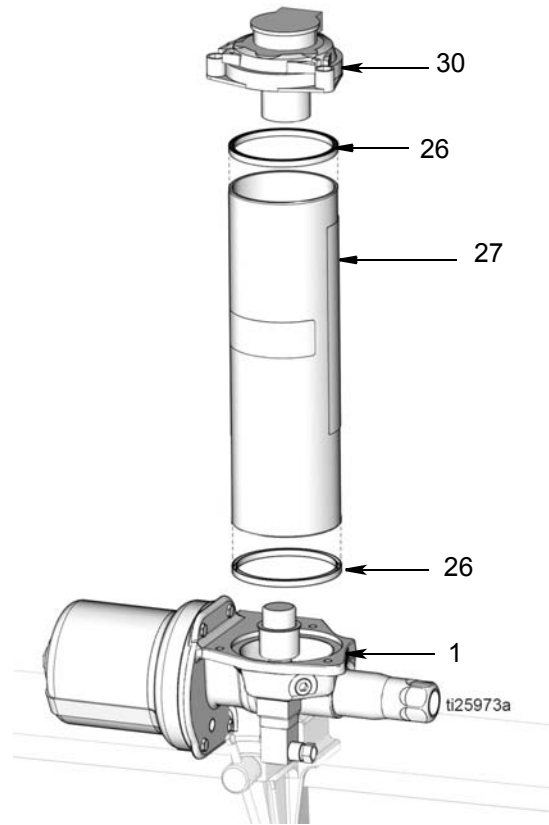

FIG. 15

12. Remove piston stop nut (3) from top of the air cylinder (2) (FIG. 16).

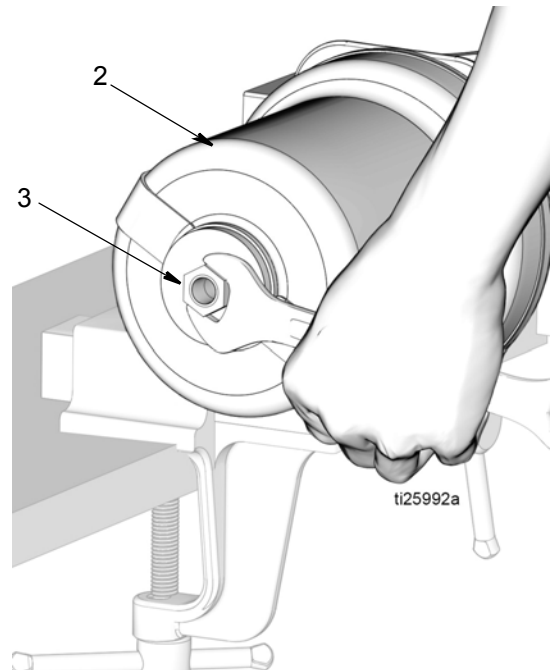

FIG. 16

13. Remove o-ring (4) from piston stop nut (3). Dispose of o-ring according to all regulations for proper disposal.

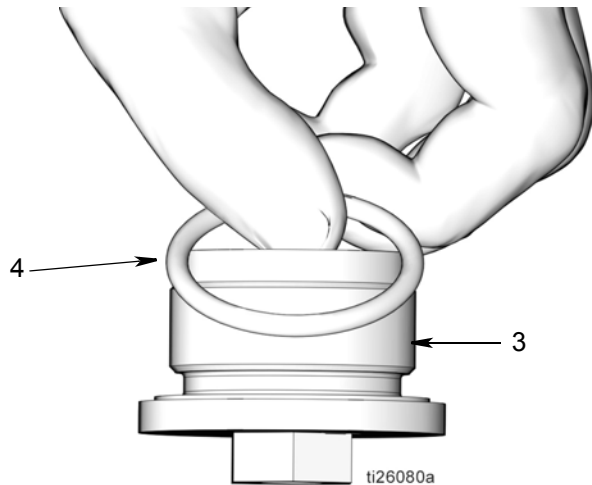

FIG. 17

14. Use a 3/8 inch socket to remove the 4 bolts (33) holding the air cylinder (2) to the pump base (1) (FIG. 18). Remove air cylinder from the pump base.

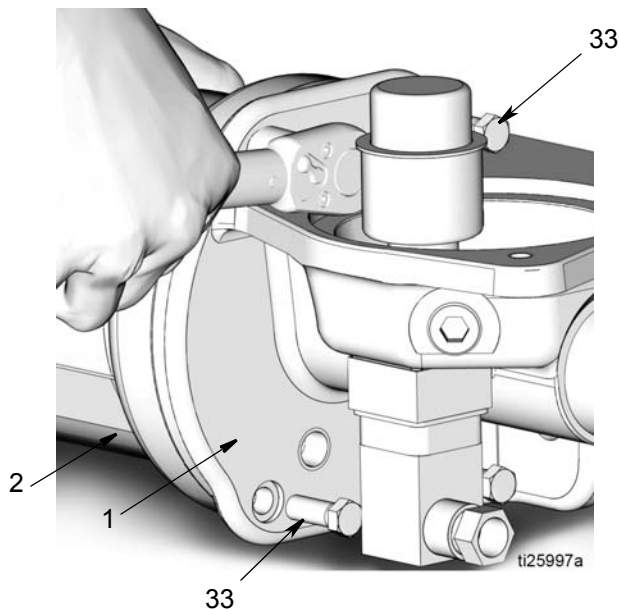

FIG. 18

15. Piston Rod (13) and Piston (6)

- a. Pull piston rod (13) and piston (6) out of air cylinder (2) (FIG. 20).

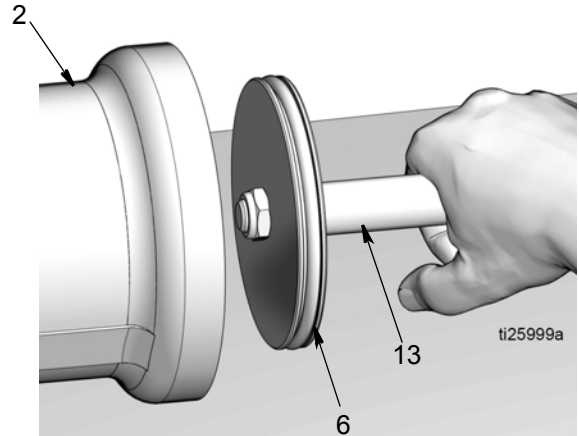

FIG. 19

- b. To separate piston rod (13) and piston (6) use two wrenches, working in opposite directions. Secure one open end wrench to flats of piston rod and the second wrench is used to loosen the nut (5) as shown in FIG. 20.

NOTE: The open end wrench secured to the flats of the piston rod is only used to hold the rod securely, do **not** rotate this wrench. Moving this wrench could scratch or damage the surface of the piston and cause fluid leaks during the pump operation. Only move the wrench holding the nut (5) to loosen and remove the nut.

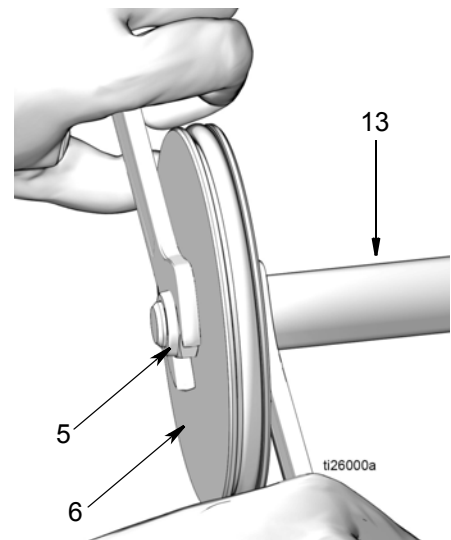

FIG. 20

- c. Remove o-ring (41) from the piston rod (13) (FIG. 21).

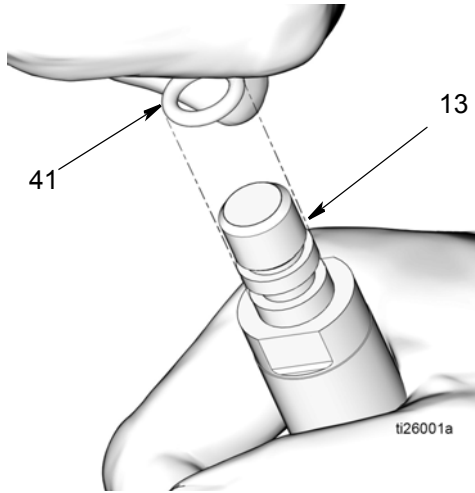

FIG. 21

- d. Remove o-ring (7) from piston (6) (FIG. 22).

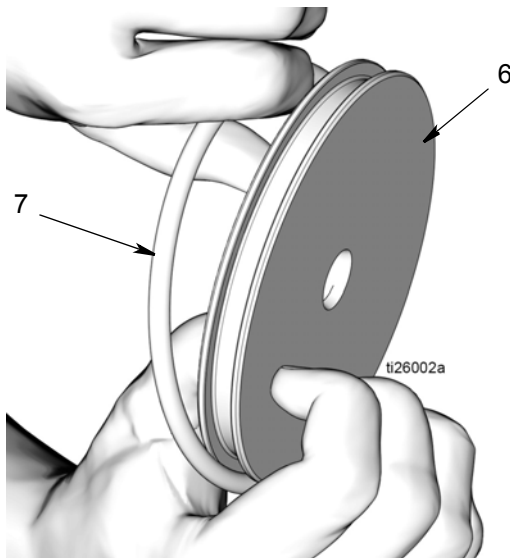

FIG. 22

- e. Discard o-rings (7, 41) and nut (5) according to all regulations for proper disposal

- 16. Remove the outlet check valve (15) from the pump base (1) (FIG. 23). Remove o-ring (4) from outlet check valve. Dispose of o-ring according to all regulations for proper disposal.

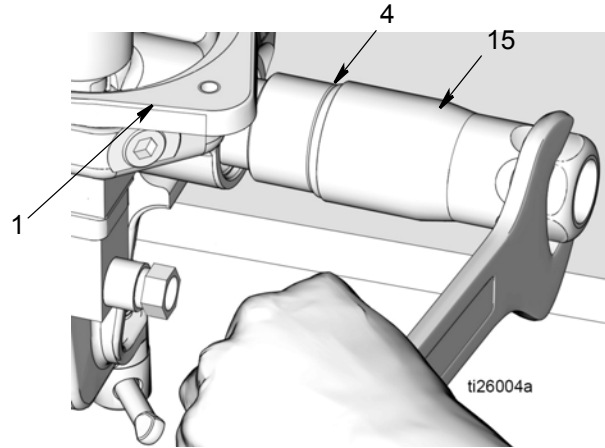

FIG. 23

- 17. Reposition the pump base (1) in the vise as shown in FIG. 24.

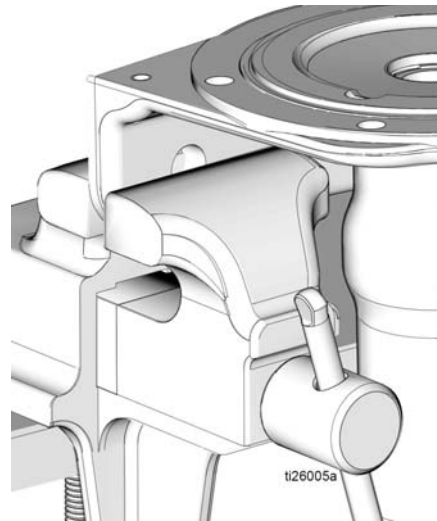

FIG. 24

18. Throat Seal Kit

The Throat Seal Kit includes the following parts (FIG. 25):

- Retaining Ring (9)
- Tapered Spacer (10)
- Seal (11)
- Spacer (12)
- Retaining Ring (51)
- Spacer (12)
- Seal (11)
- Spacer (12)

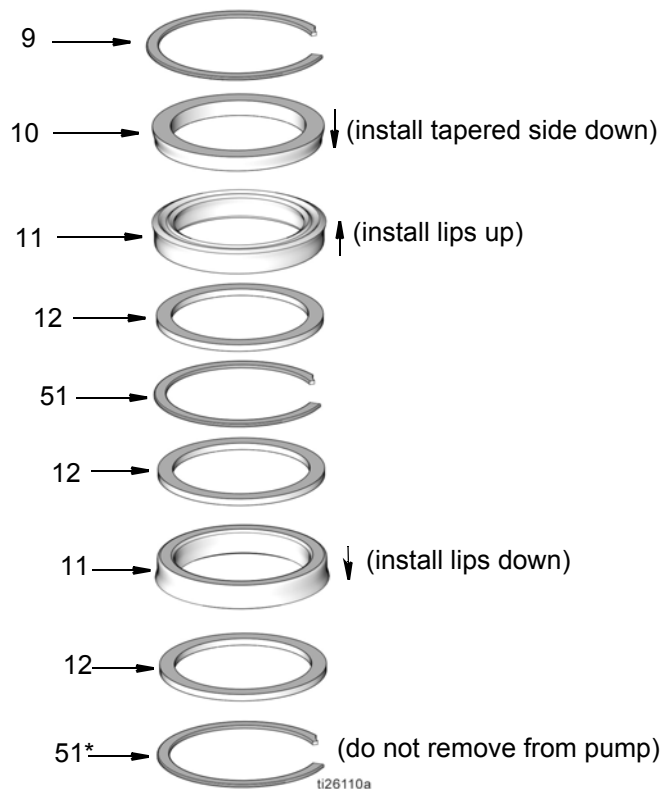

FIG. 25

*This part is shown for reference only. It is not included in the Throat Seal Kit.

- a. Slide the blade of a small, flat screw driver under the tapered edge (*te*) of retaining ring (9) and remove the ring as shown in FIG. 26.

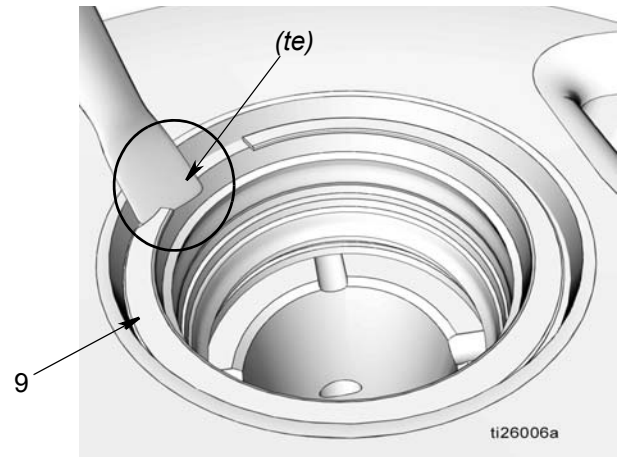

FIG. 26

- b. Remove the tapered spacer (10), seal (11), and spacer (12).
 - c. Use the blade of a small, flat screw driver under the tapered edge (*te*) of retaining ring (51) to remove the ring as shown in FIG. 26 and remove the retaining ring.
 - d. Remove spacer (12), seal (11), and spacer (12).
- DO NOT REMOVE THE LAST RETAINING RING (51).**
- e. Dispose of all parts according to all regulations for proper disposal.

19. Use a soft brass rod (*br*) and hammer to gently tap the pump element sleeve (53) out of the pump base (1) (FIG. 27).

Use your hand to catch the sleeve while tapping it out of the pump base to make sure it does not drop on the ground or table which could damage the sleeve.

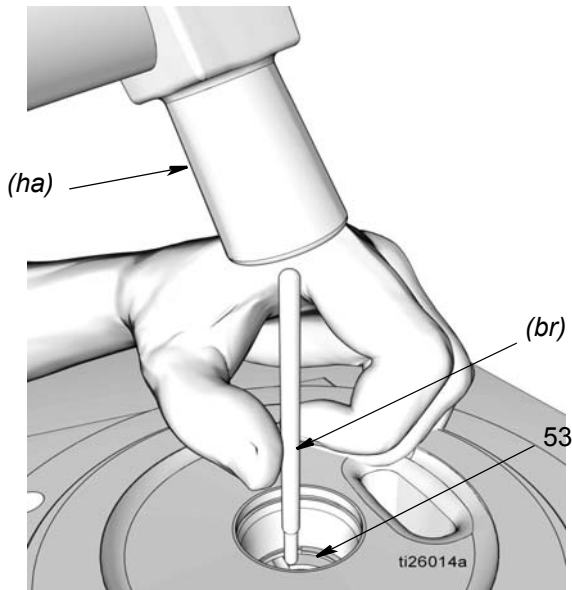

FIG. 27

NOTE: Be careful not to scratch or damage the sleeve and/or the pump base housing (1) when tapping the sleeve out of the pump base or when removing the o-ring. A scratched or damaged sleeve and or pump base housing (1) will result in fluid leaking during the pump operation and will prevent the pump from operating correctly.

20. Remove o-ring (14). Dispose of o-ring according to all regulations for proper disposal.

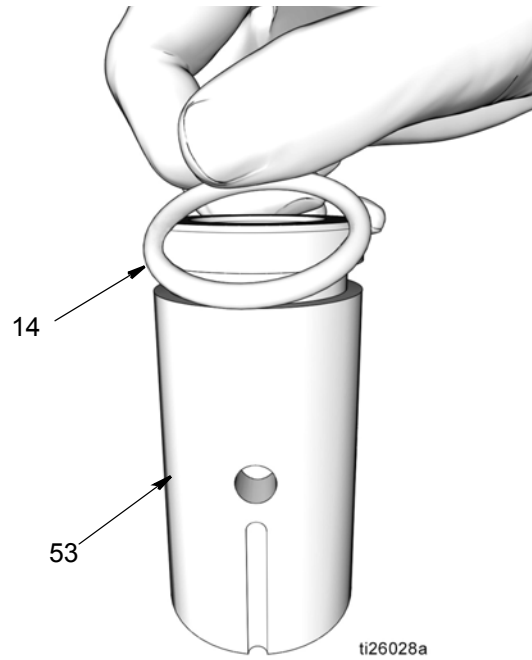

FIG. 28

21. Remove square o-ring (8) from the pump base (1) (FIG. 29). Dispose of o-ring according to all regulations for proper disposal

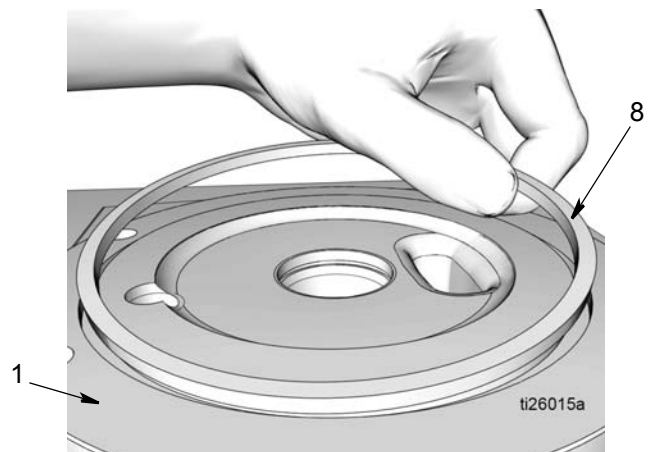

FIG. 29

Reassembly

NOTE: Always use all new parts included in replacement kits. Discard used parts according to all applicable regulations for proper disposal.

1. Use a clean cloth to wipe down the pump base (1) and remove any dirt or contaminants. Inspect surface for any scratches or damage. Replace the pump if the pump base is damaged.
2. If necessary, reposition the pump base (1) in the vise as shown in FIG. 30.

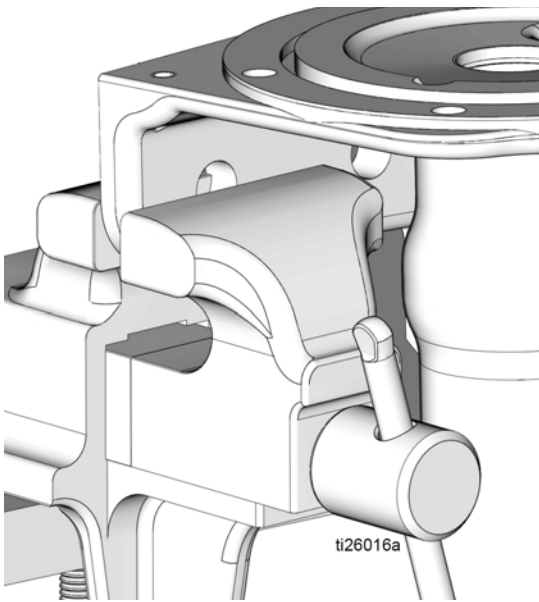

FIG. 30

3. Throat Seal Installation

The Throat Seal Kit includes the following parts (FIG. 31):

- Retaining Ring (9)
- Tapered Spacer (10)
- Seal (11)
- Spacer (12)
- Retaining Ring (51)
- Spacer (12)
- Seal (11)
- Spacer (12)

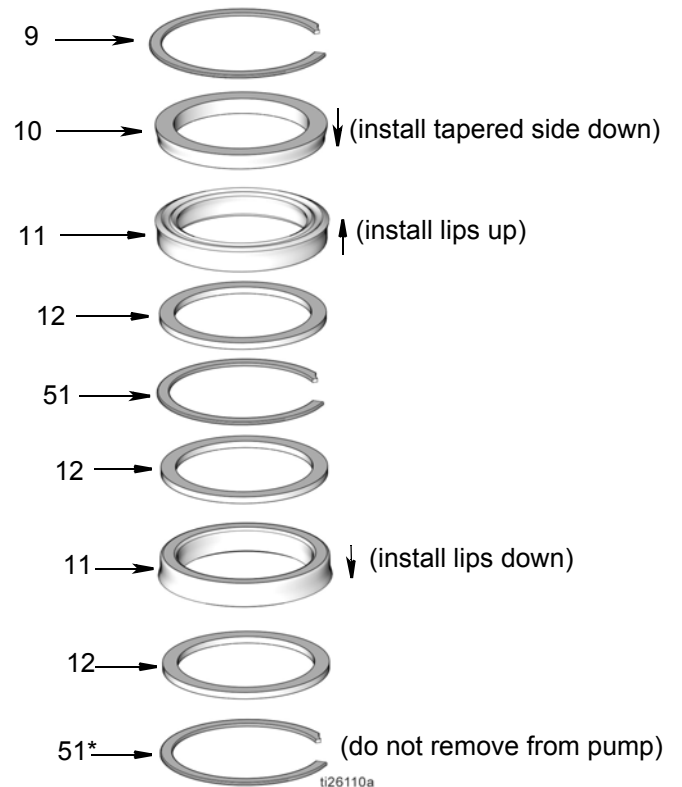

FIG. 31

*This part is shown for reference only. It is not included in the Throat Seal Kit.

- a. Apply a thin layer of grease to all the seals included in the kit and the pump base bore (*bb*).
- b. Verify retaining ring (51) is in place inside the pump base (1).
- c. Install spacer (12) shown in FIG. 32.

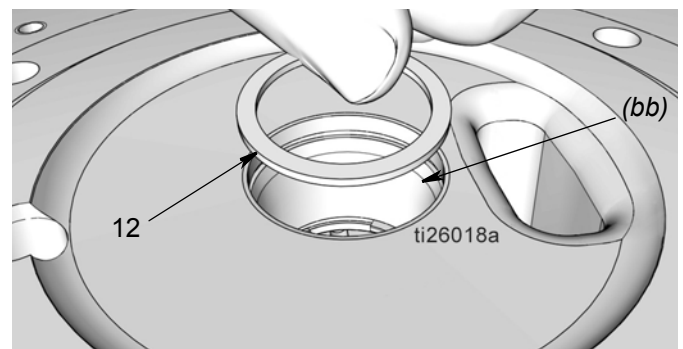

FIG. 32

- d. Install seal (11). Be sure the lips of the seal are facing down as shown in FIG. 33.

NOTE: Make sure the seal lip is not damaged while pressing the seal through the clip grooves.

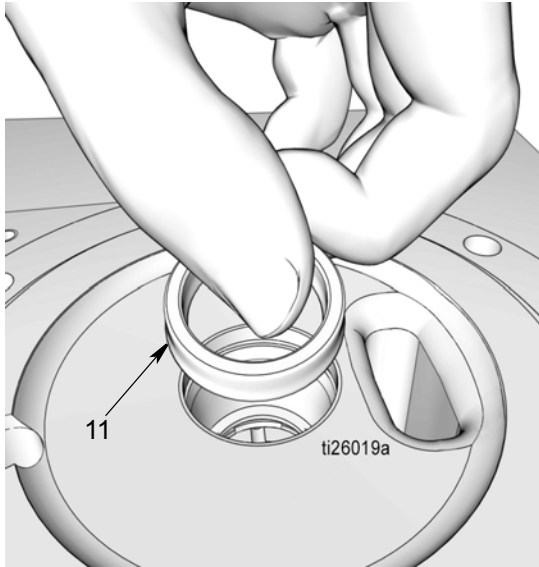

FIG. 33

- e. Install spacer (12) (FIG. 34).

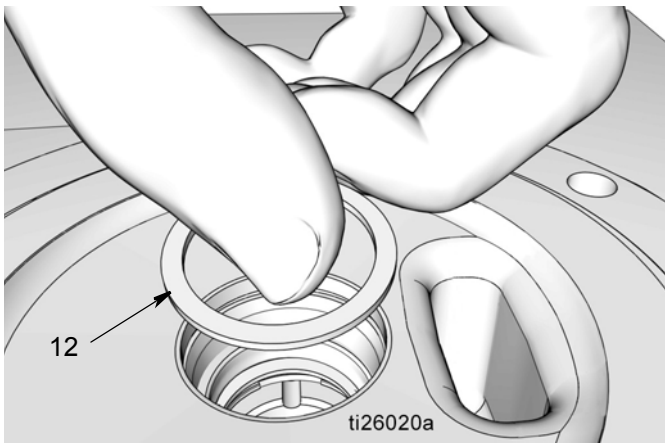

FIG. 34

- f. Install retaining clip (51) (FIG. 35). You should hear a “click” when the retaining clip is correctly seated in the groove.

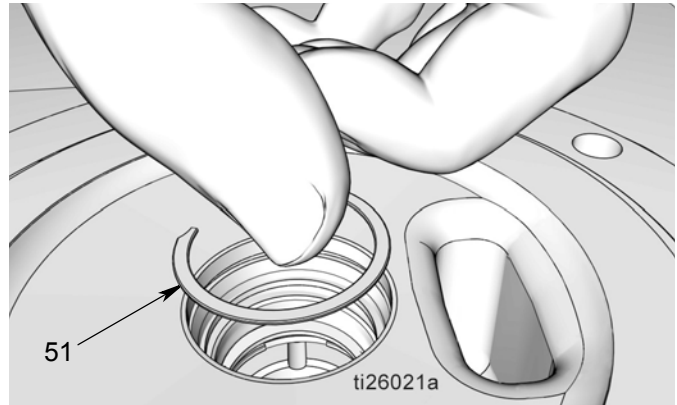

FIG. 35

- g. Install spacer (12) (FIG. 35).

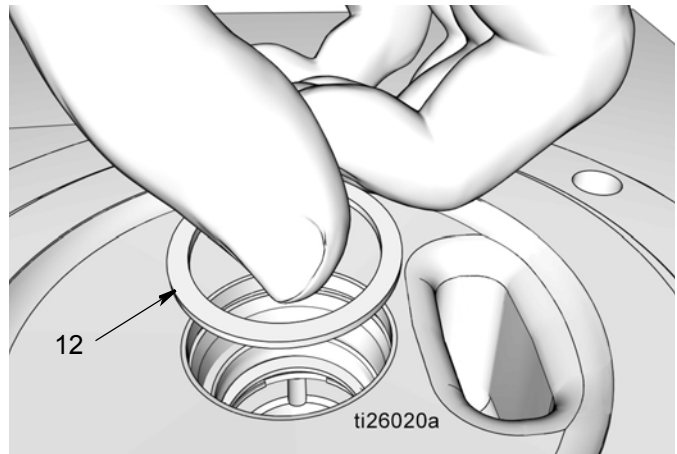

FIG. 36

- h. Install seal (11), with the lips facing up as shown in FIG. 37.

NOTE: Make sure the seal lip is not damaged while pressing the seal through the clip grooves.

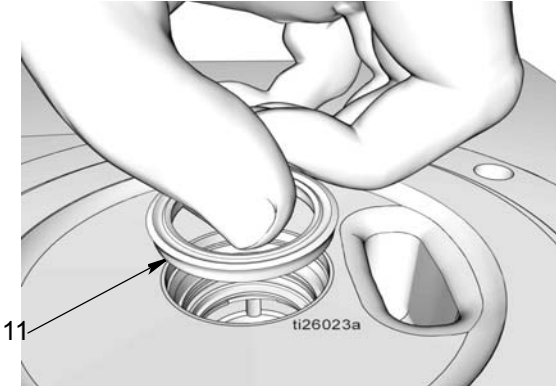

FIG. 37

- i. Install the tapered spacer (10), tapered side facing down as shown in FIG. 38.

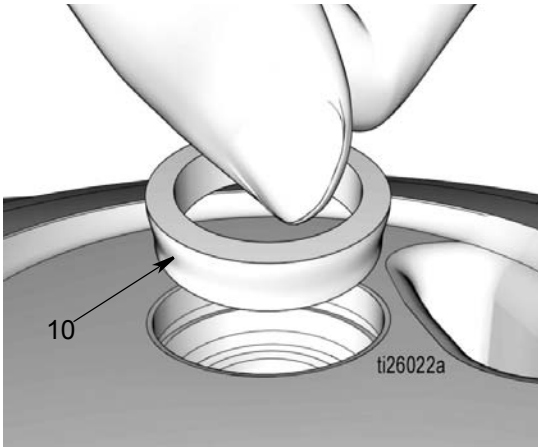

FIG. 38

- j. Install clip (9) (FIG. 39). You should hear a “click” when the retaining clip is correctly seated in the groove.

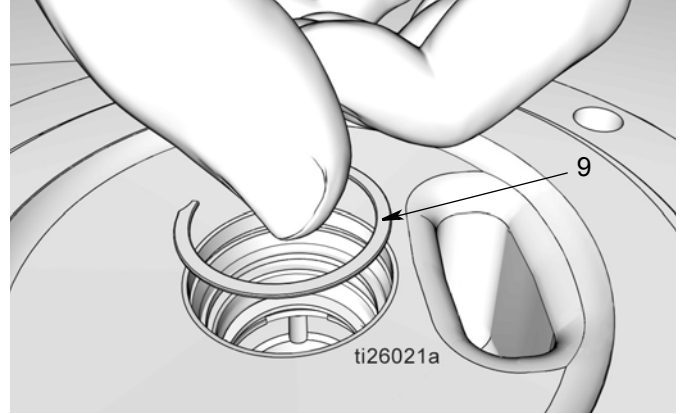

FIG. 39

- 4. Reposition the pump base (1) in the vise as shown in FIG. 40.

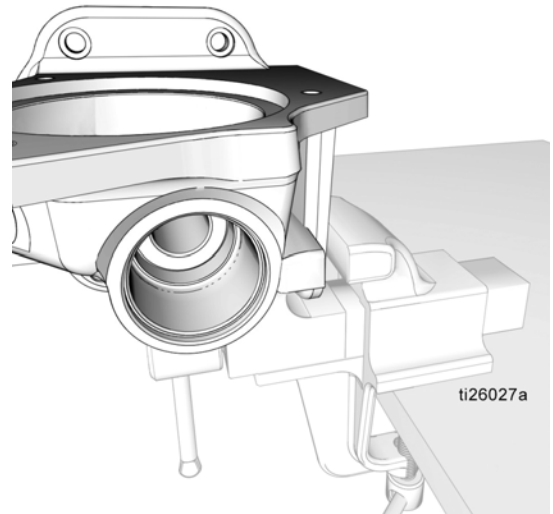

FIG. 40

5. Pump Element Sleeve (53)

- a. Use a clean cloth to wipe down the pump element sleeve (53) and remove any dirt or contaminants. Inspect surface for any scratches or damage.
- b. Apply a thin layer of grease to o-ring (14). Install o-ring around the pump element sleeve (d) (FIG. 41).

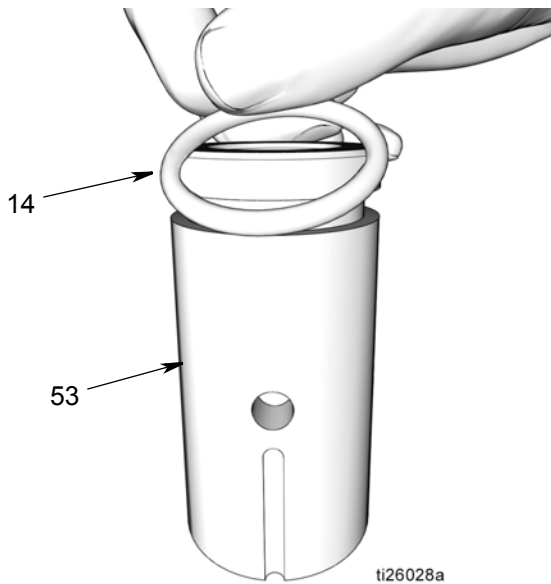

FIG. 41

- c. Install the pump element sleeve (53) in the pump base (1). To determine the correct installation orientation, refer to FIG. 42.

NOTE: When the sleeve is installed in the pump base correctly, the notches (*n*) around the bottom of the sleeve will go into the pump base first and the o-ring will be on the top.

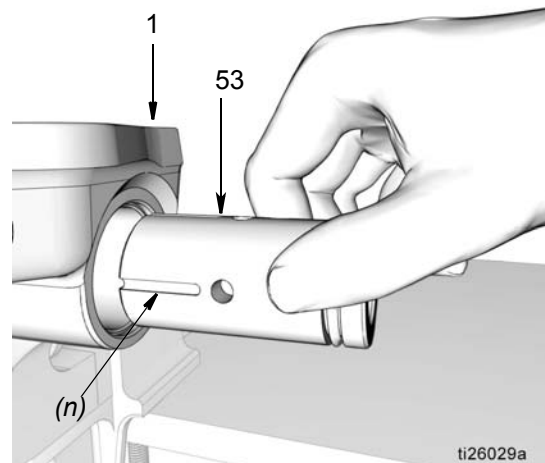

FIG. 42

- d. Use your thumbs to press the sleeve (53) into the pump base (1). Then using a soft rod, press the sleeve all the way down as far as possible (FIG. 43).

NOTE: Be careful not to scratch or damage the sleeve and/or the pump base housing (1) when installing the sleeve in the pump base. Scratched or damaged surfaces will create a path for the fluid to leak during the pump operation and will prevent the pump from operating correctly.

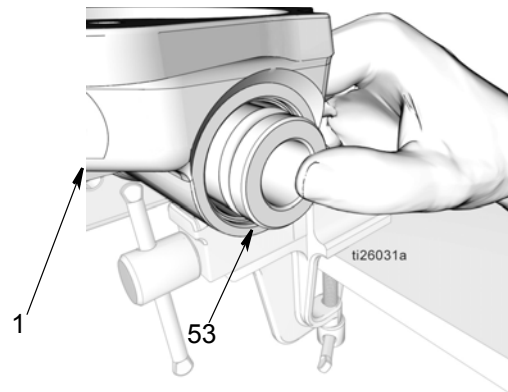

FIG. 43

6. Outlet Check Valve (15)

- a. Use a clean cloth to wipe down the outlet check valve (15) and remove any dirt or contaminants. Inspect surface for any scratches or damage. Replace damaged parts.

NOTE: The outlet check valve consists of a ball check inside the bore. It is not repairable. If there is any damage or contamination in the bore, replace the check valve.

- b. Apply a thin layer of grease to o-ring (4). Install o-ring around the outlet check valve (15) (FIG. 44).

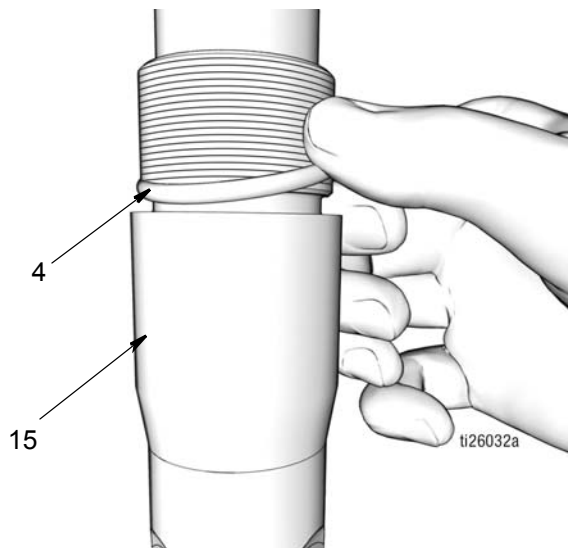

FIG. 44

- c. Thread the outlet check valve (15) into the pump base (1) (FIG. 45). Tighten securely. Then torque to 50 to 55 ft. lbs (67.8 to 74.5 N•m).

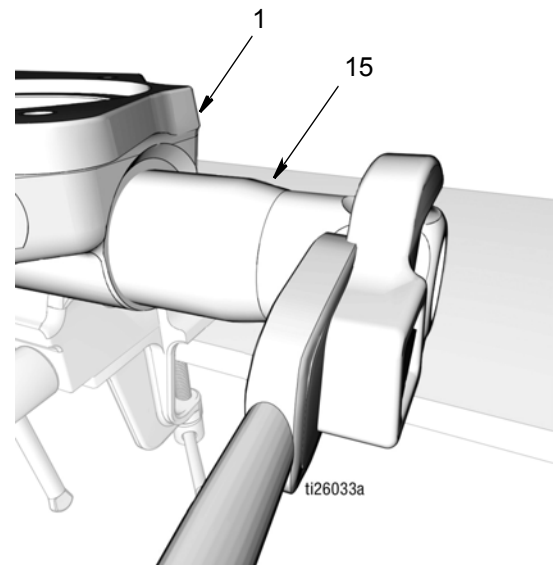

FIG. 45

7. Apply a thin layer of grease to square o-ring (8). Install square o-ring (8) in groove in the pump base (1) as shown in FIG. 46.

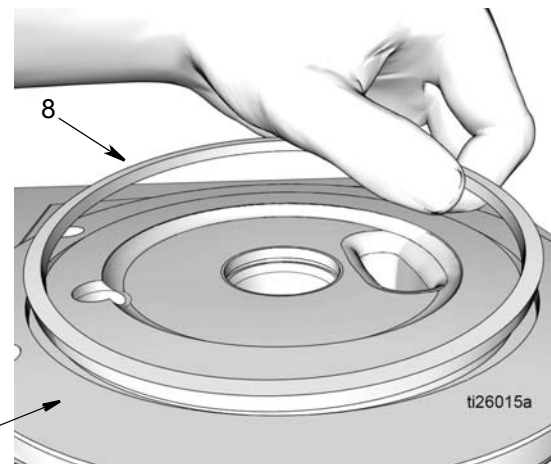

FIG. 46

8. Piston Rod (13) and Piston (6)

NOTE: Do not clamp piston rod (13) in vise.

- a. Use a clean cloth to wipe down the piston rod (13) and piston (6) and remove any dirt or contaminants. Inspect surfaces for any scratches or damage. Replace damaged parts.
- b. Apply a thin layer of grease to o-ring (41). Install o-ring over the grooves of the piston rod (13) (FIG. 47).

NOTE: If needed, a pick can be used to help seat the o-ring over the grooves of the piston rod (13).

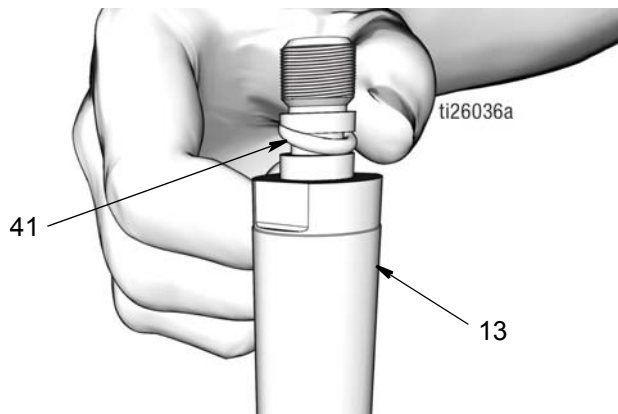

FIG. 47

- c. Push piston (6) over end of piston rod (13) until it is seated on the rod (FIG. 48).

NOTE: You should hear a pop sound when it is in place correctly.

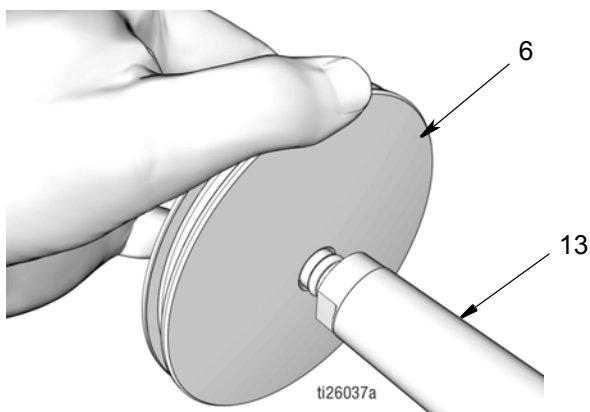

FIG. 48

- d. Install nut (5) over the end of the piston rod (13). Use two wrenches, working in opposite directions to tighten the nut. Secure one open end wrench to flats of piston rod and use the second wrench to tighten the nut (5) as shown in FIG. 49.

NOTE: The open end wrench secured to the flats of the piston rod is only used to hold the rod securely, do **not** rotate this wrench. Moving this wrench could scratch or damage the surface of the piston and cause fluid leaks during the pump operation. Only move the wrench holding the nut (5) to tighten the nut. Torque nut to 15 to 17 ft. lbs (20.3 to 23.1 N•m).

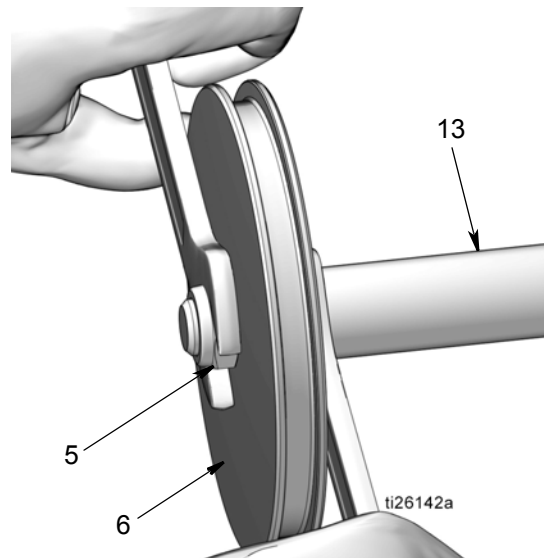

FIG. 49

- e. Apply a thin layer of grease to o-ring (7). Install o-ring (7) around piston (6) as shown in FIG. 50.

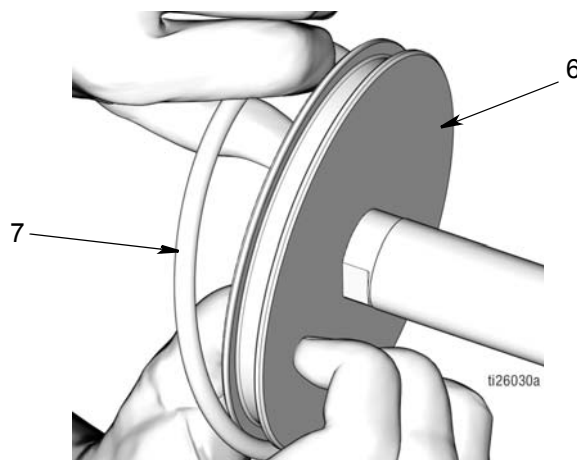

FIG. 50

- f. Apply a thin layer of grease around and along the entire length of the piston rod (13). Gently push the piston rod into the pump base (1) using a push and turn motion to work the rod through the previously installed, seals and spacers (FIG. 51).

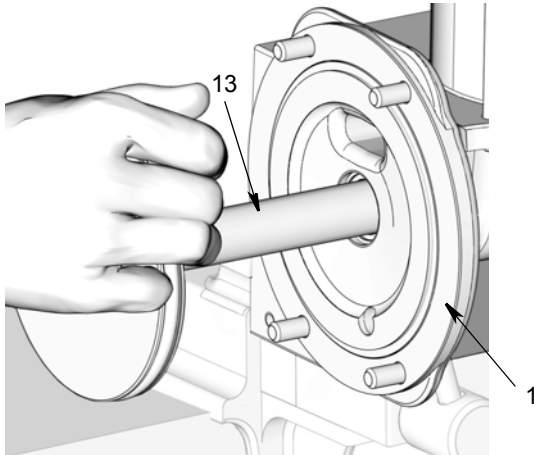

FIG. 51

9. Air Cylinder

- a. Use a clean cloth to wipe inside the air cylinder (2) and remove any dirt or contaminants.
- b. Apply a thin layer of grease to the inside surfaces of the air cylinder (2). Slide the air cylinder (2) over the piston (6) and push it all the way down until it is seated tightly to the pump base (1). See FIG. 52.

Make sure the Graco G in the air cylinder is facing out.

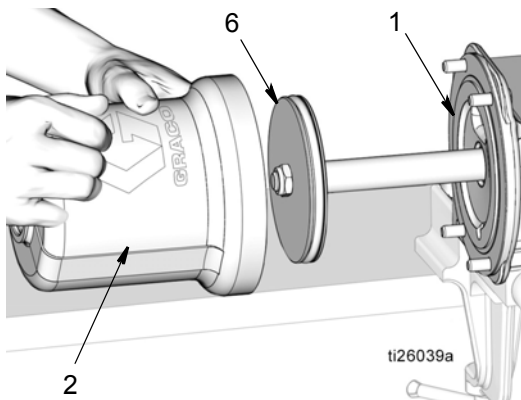

FIG. 52

- c. Install 4 new bolts. Hand tighten the bolts (33) evenly, each one a little at a time in a diagonal pattern. Then torque diagonally to 10-13 ft. lbs. (13.5-17.6 N•m). See FIG. 53.

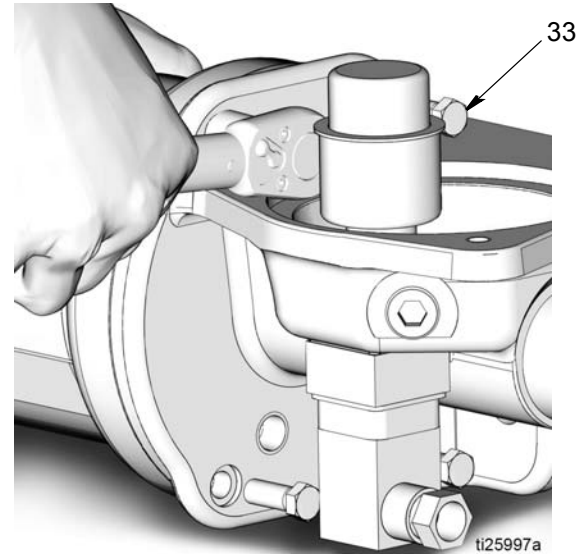

FIG. 53

- d. Apply a thin layer of grease to o-ring (4). Install o-ring to piston stop nut (3) (FIG. 54).

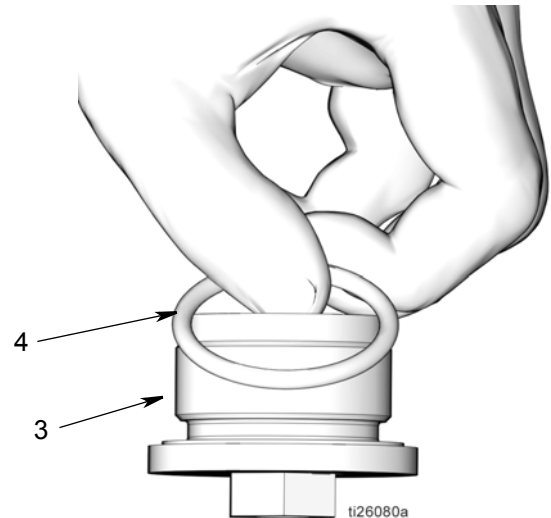

FIG. 54

- e. Thread piston stop nut (3) into top of air cylinder (2) as shown in FIG. 55. Wrench tighten nut. Then torque nut to 15 to 17 ft. lbs (20.3 to 23.1 N•m).

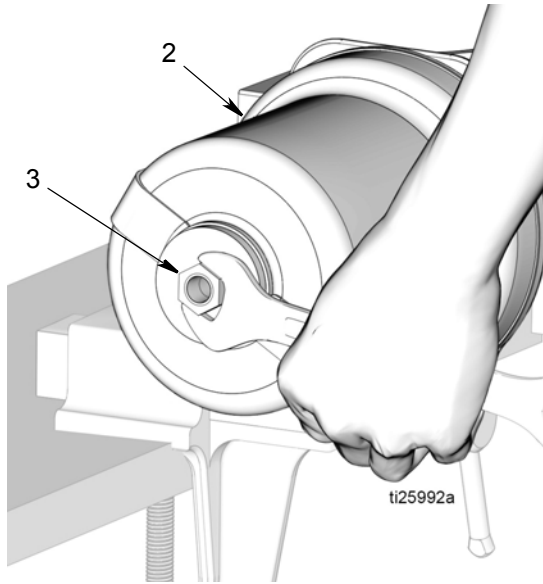

FIG. 55

10. Install reservoir gaskets (26) to top and bottom of reservoir (27) as shown in FIG. 56.

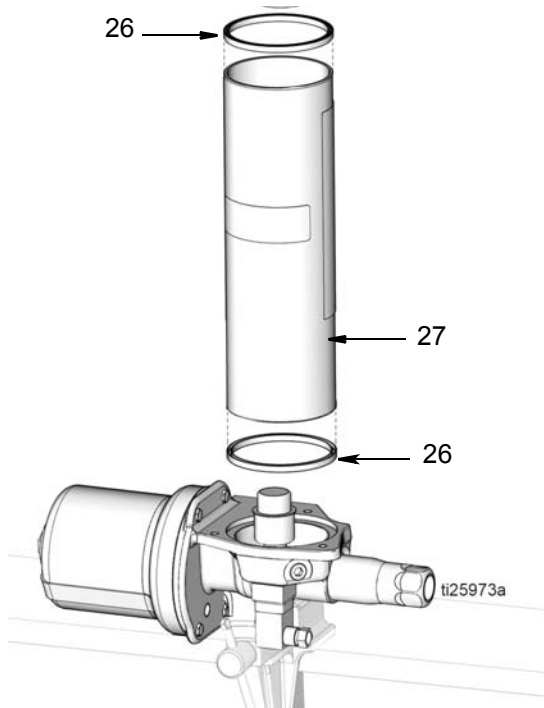

FIG. 56

11. Install reservoir (27) in the pump base (1) (FIG. 57).

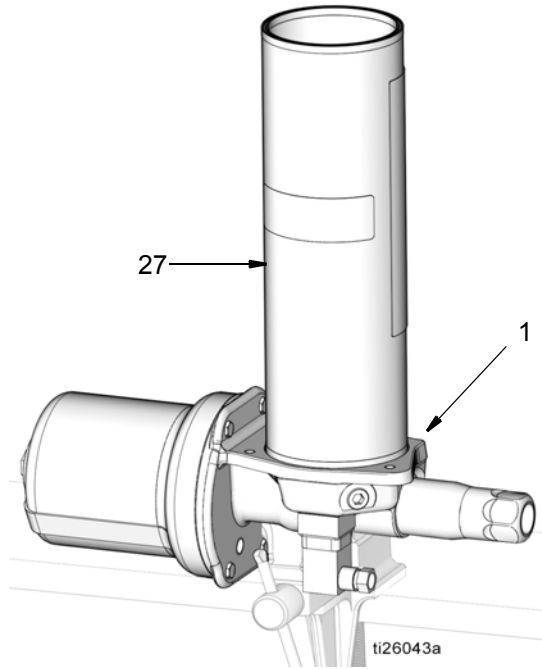

FIG. 57

12. Install cover over reservoir gasket (26). Install spacer (20) and tie rods (29) (FIG. 58).

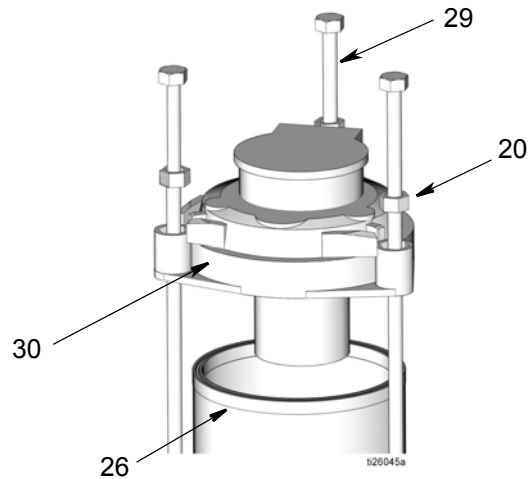

FIG. 58

13. Evenly tighten tie rods (29) in a diagonal pattern, a little at a time. Torque to 9-11 in. lbs. (1.0 - 2.4 N•m). Take care not to over tighten any of the rods. This could damage the gasket and break the reservoir.
14. Reinstall the pump in the service location. See Installation Instructions beginning on page 5.

Troubleshooting



Problem	Cause	Solution
The pump is not operating. No lubricant flow.	No air	<ol style="list-style-type: none"> 1. Adjust air pressure/supply. 2. Open bleed-type master air valve (F) (page 5).
	No lubricant in reservoir	Fill the reservoir.
	Losing prime	<ol style="list-style-type: none"> 1. Remove trapped air (see Air Lock, page 9). 2. Prime the pump (Priming, page 8).
Injectors not cycling or only some of the injectors are operating	No lubricant flow	See Pump is not operating. No lubricant flow in Troubleshooting table.
	Low pressure or no pressure	<ol style="list-style-type: none"> 1. Check piping for leaks. If a leak is detected, repair or replace piping. 2. Check injectors for leaks. If a leak is detected, repair or replace injector. 3. If the total system volume is greater than the Pump Lubricant Output provided in Table 1 or Table 2, split the system into two or more systems. Refer to Lubrication System Sizing and Calibration Guide, page 28.
	Pump seals are bad	Replace seals. See Parts, page 29.

Parts

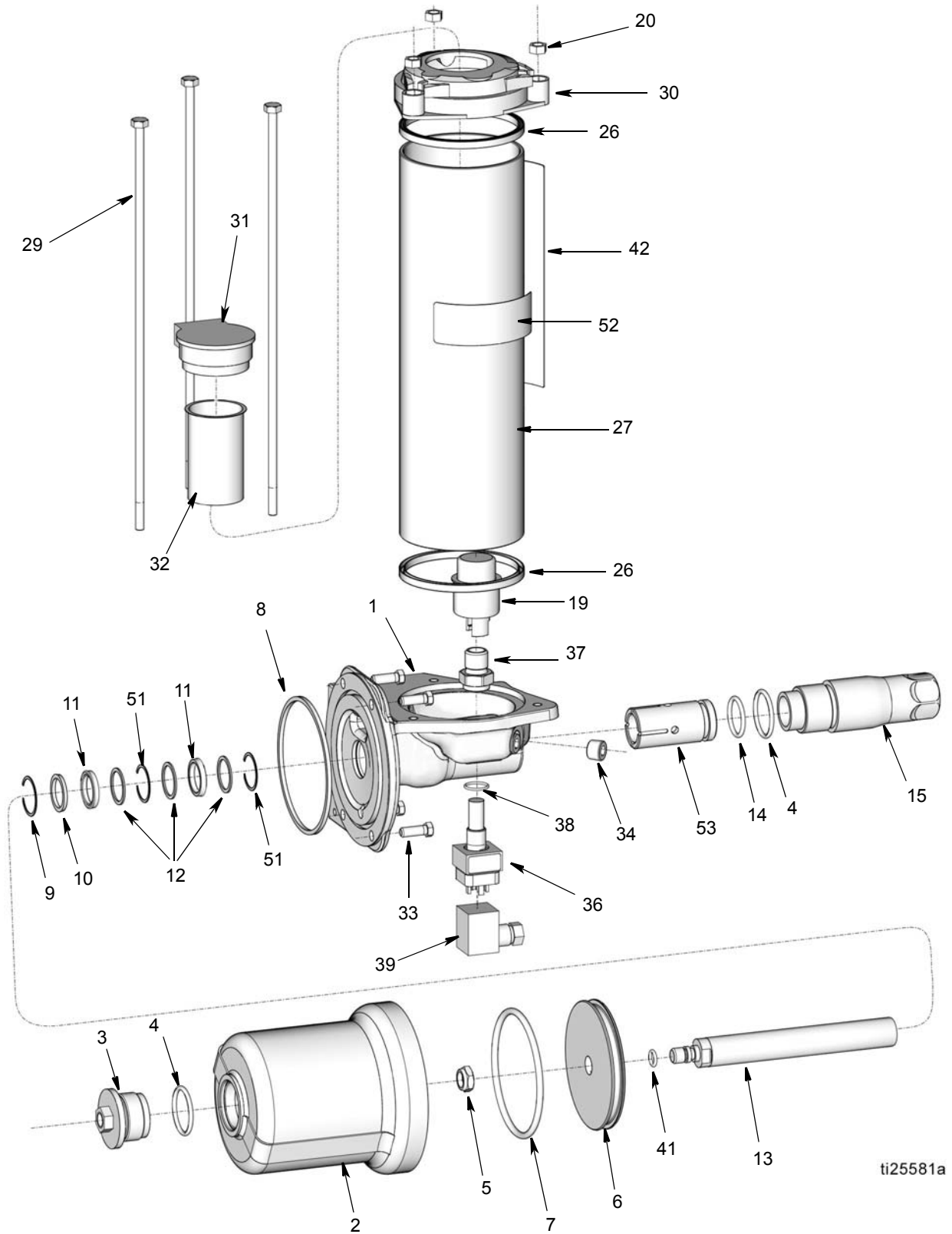

ti25581a

Parts

Ref	Part No.	Description	Qty
1		PUMP BASE	1
2	160613	CYLINDER, air	1
3		NUT, piston stop	1
4	◆156698	PACKING, o-ring	2
5	◆	NUT, hex, lock, nylon, thin	1
6		PISTON, air	1
7	◆	PACKING, o-ring	1
8	◆	PACKING, square	1
9	◆	RING, retaining internal	1
10	◆	SPACER, seal. wedge	1
11	◆	SEAL, oil	2
12	◆	SPACER, seal	3
13		PISTON	1
14	◆	PACKING, o-ring	1
15	17D305	VALVE, dual outlet check	1
19	❖	FLOAT, low level (model, 17C752, 18C752)	1
20	557965	SPACER, AL 0.343 in. 0.5 hex X 0.25	3
26	†	GASKET, 5 lb, reservoir	2
27	†	RESERVOIR, 5 lb plastic	1
29		ROD, tie, 5/12 lb. reservoir	3
30		CAP, reservoir	1
31	557797	CAP, fill, reservoir	1
32	557799	SCREEN, filter	1
33	101578	SCREW, cap, hex, hd	4
34	101754	PLUG, pipe	1
36	❖	SENSOR, low level	1
37		NUT, low level float mount	1
38	❖	PACKING, o-ring	1
39	❖	CONNECTOR, DIN, Form A, 4-pin (models 17C752, 18C752)	1
41	◆	PACKING, o-ring	1
42▲	†17C560	LABEL, safety, warning	1
51	◆	RING, snap	2
52	†128199	LABEL, branding	1
53		SLEEVE, pump element	1

▲ Replacement Danger and Warning labels, tags and cards are available at no cost.

◆ Included in Seal Replacement Kit 24X889.
NOTE: Only one (#51) is included in the kit.

† Included in Oil Reservoir Kit 24X888

❖ Included in Oil Low Level Kit 24Y933

Technical Data

19:1 Single Stroke Oil Pump with Low Level		
	US	Metric
Maximum fluid working pressure	3500 psi	24 MPa, 241 bar
Pressure ratio	19:1	19:1
Pump output	3.0 cu. inch/stroke	
Reservoir capacity	4 lb (120 cu. in.)	
Maximum air inlet pressure	185 psi	1.27 MPa, 12.76 bar
Air inlet size	1/4 in. NPT★	
Fluid outlet size	3/4 in. NPT‡	
Filling	Top cover with strainer	
Wetted Parts	Pump: high phosphorus electroless nickel plated ductile iron, zinc nickel coated steel, acetal plastic, 6061 aluminum alloy Reservoir: polycarbonate Seals: Buna-N (nitrile)	
Approximate weight	22 lbs	9.9 kg
Operating temperature	14°F to 149°F	-10°C to 65°C
Low Level		
Maximum switching current	0.25 Amps	
Voltage	12-130 DC/AC	
IP ratings	IP65 when plugged and screwed down	
Cable diameter	0.315 to 0.394 inches	8 to 10 mm
Wire size	20 to 16 AWG	0.5 to 1.5 mm ²

★ Models 20C752 is supplied with three, 1/4 in. NPT(m) x 1/4 in. BSPP(f) fittings as loose items. Two are supplied for the air inlet and one for the pump outlet.

‡ All the pumps are supplied with 3/4 in. NPT(m) x 1/4 inch NPT(f) reducers if needed.

Graco Standard Warranty

Graco warrants all equipment referenced in this document which is manufactured by Graco and bearing its name to be free from defects in material and workmanship on the date of sale to the original purchaser for use. With the exception of any special, extended, or limited warranty published by Graco, Graco will, for a period of twelve months from the date of sale, repair or replace any part of the equipment determined by Graco to be defective. This warranty applies only when the equipment is installed, operated and maintained in accordance with Graco's written recommendations.

This warranty does not cover, and Graco shall not be liable for general wear and tear, or any malfunction, damage or wear caused by faulty installation, misapplication, abrasion, corrosion, inadequate or improper maintenance, negligence, accident, tampering, or substitution of non-Graco component parts. Nor shall Graco be liable for malfunction, damage or wear caused by the incompatibility of Graco equipment with structures, accessories, equipment or materials not supplied by Graco, or the improper design, manufacture, installation, operation or maintenance of structures, accessories, equipment or materials not supplied by Graco.

This warranty is conditioned upon the prepaid return of the equipment claimed to be defective to an authorized Graco distributor for verification of the claimed defect. If the claimed defect is verified, Graco will repair or replace free of charge any defective parts. The equipment will be returned to the original purchaser transportation prepaid. If inspection of the equipment does not disclose any defect in material or workmanship, repairs will be made at a reasonable charge, which charges may include the costs of parts, labor, and transportation.

THIS WARRANTY IS EXCLUSIVE, AND IS IN LIEU OF ANY OTHER WARRANTIES, EXPRESS OR IMPLIED, INCLUDING BUT NOT LIMITED TO WARRANTY OF MERCHANTABILITY OR WARRANTY OF FITNESS FOR A PARTICULAR PURPOSE.

Graco's sole obligation and buyer's sole remedy for any breach of warranty shall be as set forth above. The buyer agrees that no other remedy (including, but not limited to, incidental or consequential damages for lost profits, lost sales, injury to person or property, or any other incidental or consequential loss) shall be available. Any action for breach of warranty must be brought within two (2) years of the date of sale.

GRACO MAKES NO WARRANTY, AND DISCLAIMS ALL IMPLIED WARRANTIES OF MERCHANTABILITY AND FITNESS FOR A PARTICULAR PURPOSE, IN CONNECTION WITH ACCESSORIES, EQUIPMENT, MATERIALS OR COMPONENTS SOLD BUT NOT MANUFACTURED BY GRACO. These items sold, but not manufactured by Graco (such as electric motors, switches, hose, etc.), are subject to the warranty, if any, of their manufacturer. Graco will provide purchaser with reasonable assistance in making any claim for breach of these warranties.

In no event will Graco be liable for indirect, incidental, special or consequential damages resulting from Graco supplying equipment hereunder, or the furnishing, performance, or use of any products or other goods sold hereto, whether due to a breach of contract, breach of warranty, the negligence of Graco, or otherwise.

FOR GRACO CANADA CUSTOMERS

The Parties acknowledge that they have required that the present document, as well as all documents, notices and legal proceedings entered into, given or instituted pursuant hereto or relating directly or indirectly hereto, be drawn up in English. Les parties reconnaissent avoir convenu que la rédaction du présente document sera en Anglais, ainsi que tous documents, avis et procédures judiciaires exécutés, donnés ou intentés, à la suite de ou en rapport, directement ou indirectement, avec les procédures concernées.

Graco Information

For the latest information about Graco products, visit www.graco.com.

For patent information, see www.graco.com/patents.

TO PLACE AN ORDER, contact your Graco distributor or call to identify the nearest distributor.

Phone: 612-623-6928 or **Toll Free:** 1-800-533-9655, **Fax:** 612-378-3590

All written and visual data contained in this document reflects the latest product information available at the time of publication. Graco reserves the right to make changes at any time without notice.

Original instructions. This manual contains English. MM 3A3232

Graco Headquarters: Minneapolis

International Offices: Belgium, China, Japan, Korea

GRACO INC. AND SUBSIDIARIES • P.O. BOX 1441 • MINNEAPOLIS MN 55440-1441 • USA
Copyright 2015, Graco Inc. All Graco manufacturing locations are registered to ISO 9001.

www.graco.com

April 2019