

# Harrier+<sup>®</sup> Chemical Injection Controller

3A4130G  
EN

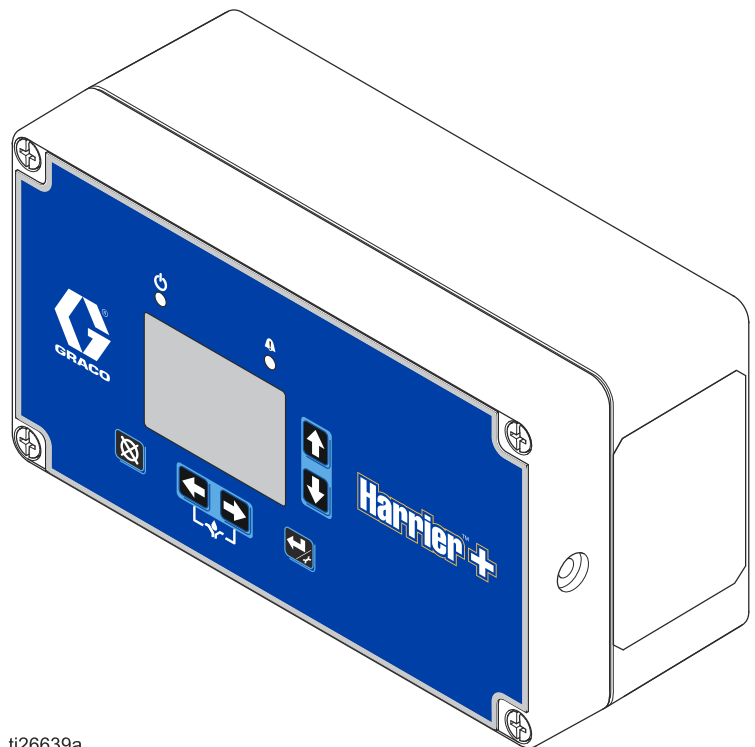
*For controlling and monitoring an automated chemical injection system. Approved for use in Class I, Div 2, Groups A, B, C, D, T4.*

See page 3 for approvals and model information.



## Important Safety Instructions

Read all warnings and instructions in this manual.  
Save these instructions.



ti26639a

# Table of Contents

Models	3	Cellular Connection Status Codes	72
<b>Warnings</b>	<b>4</b>	Program Settings	73
<b>Component Identification</b>	<b>6</b>	<b>Dimensions and Mounting Hole Layout</b>	<b>75</b>
Keypad, Display, and Icons	6	<b>Kits and Accessories</b>	<b>75</b>
<b>Installation</b>	<b>9</b>	<b>Appendix A: Modbus Interface</b>	<b>76</b>
Installing the Injection Controller	9	PC Interface	76
Grounding	9	PLC Interface	76
Antenna Connection	9	Variable Maps	77
Typical 12 or 24 VDC Installation and Wiring	10	<b>Technical Data</b>	<b>87</b>
Typical 120 VAC Installation and Wiring	14	<b>Graco Standard Warranty</b>	<b>88</b>
Typical 240 VAC Installation and Wiring	18	<b>Graco Information</b>	<b>88</b>
<b>Wiring Diagrams</b>	<b>22</b>		
<b>Theory of Operation</b>	<b>33</b>		
Flow Control Summary	33		
Cycle Control Summary	33		
Time Control Summary	33		
Pump Calibration	33		
<b>Controller Setup</b>	<b>34</b>		
Configuration Screen	34		
Pump Setup Screen (Flow Mode)	34		
Pump Setup Screen (Time Mode)	37		
Pump Setup Screen (Cycle Mode)	37		
Alarms Setup Screen	38		
PIN Code Setup Screen	42		
PIN Code Entry Screen	43		
Network Setup Screen	44		
Advanced Setup Screen	45		
Fluid Pressure Setup Screen	50		
Tank Level Setup Screen	50		
Run Screens	50		
Screen Identification	50		
Alarms and Signal Events	51		
<b>Harrier+ Web Portal</b>	<b>53</b>		
Creating a New Account	54		
Logging In to the Web Portal	56		
Pumps List Screen	58		
Pumps Detail Screen (Pump Connected)	59		
Pumps Detail Screen (Pump Disconnected)	63		
Groups List Screen	64		
Groups Detail Screen	65		
Invitation to Join a Group	67		
Settings Screen	68		
Help Screen	69		
<b>Troubleshooting</b>	<b>70</b>		

# Approvals



## Related Manuals







Manual No.	Description
3A3100	Wolverine Premium Chemical Injection System
334513	Wolverine Chemical Injection Pump
3A5375	Tank Level Monitoring Kit
3A3210	Firmware Update Manual

## Models

Part No.	Description
B32627	Harrier+ Controller, DC Power, Cellular - USA only (GSM - AT&T)
B32628	Harrier+ Controller, AC Power, Cellular - USA only (GSM - AT&T)
B32629	Harrier+ Controller, DC Power, Cellular - Global (limited use in USA)
B32630	Harrier+ Controller, AC Power, Cellular - Global (limited use in USA)
B32631	Harrier+ Controller, DC Power, SCADA via MODBUS
B32632	Harrier+ Controller, AC Power, SCADA via MODBUS
B32643	Harrier+ Controller, DC Power, Cellular - USA only (CDMA - Verizon)
B32644	Harrier+ Controller, AC Power, Cellular - USA only (CDMA - Verizon)

# Warnings

The following warnings are for the setup, use, grounding, maintenance, and repair of this equipment. The exclamation point symbol alerts you to a general warning and the hazard symbols refer to Procedure-specific risks. When these symbols appear in the body of this manual or on warning labels, refer back to these Warnings. Product-specific hazard symbols and warnings not covered in this section may appear throughout the body of this manual where applicable.

 <span style="font-size: 2em; font-weight: bold; margin-left: 10px;">WARNING</span>	
 	<p><b>FIRE AND EXPLOSION HAZARD</b></p> <p>When flammable fluids are present in the work area be aware that flammable fumes can ignite or explode. To help prevent fire and explosion:</p> <ul style="list-style-type: none"> <li>• Use equipment only in well ventilated area.</li> <li>• Eliminate all ignition sources, such as cigarettes and portable electric lamps.</li> <li>• Ground all equipment in the work area.</li> <li>• Keep work area free of debris, including rags and spilled or open containers of solvent.</li> <li>• Do not plug or unplug power cords or turn lights on or off when flammable fumes are present.</li> <li>• Use only grounded hoses.</li> <li>• <b>Stop operation immediately</b> if static sparking occurs or you feel a shock. Do not use equipment until you identify and correct the problem.</li> <li>• Keep a working fire extinguisher in the work area.</li> </ul>
	<p><b>FIRE AND EXPLOSION HAZARD</b></p> <p>Static charge may build up on plastic parts during cleaning and could discharge and ignite flammable vapors. To help prevent fire and explosion:</p> <ul style="list-style-type: none"> <li>• Clean plastic parts only in well ventilated area.</li> <li>• Do not clean with a dry cloth.</li> </ul>
 	<p><b>ELECTRIC SHOCK HAZARD</b></p> <p>This equipment must be grounded. Improper grounding, setup, or usage of the system can cause electric shock.</p> <ul style="list-style-type: none"> <li>• Turn off and disconnect power at main switch before disconnecting any cables and before servicing or installing equipment.</li> <li>• Connect only to grounded power source.</li> <li>• All electrical wiring must be done by a qualified electrician and comply with all local codes and regulations.</li> </ul>

 **WARNING****EQUIPMENT MISUSE HAZARD**

Misuse can cause death or serious injury.

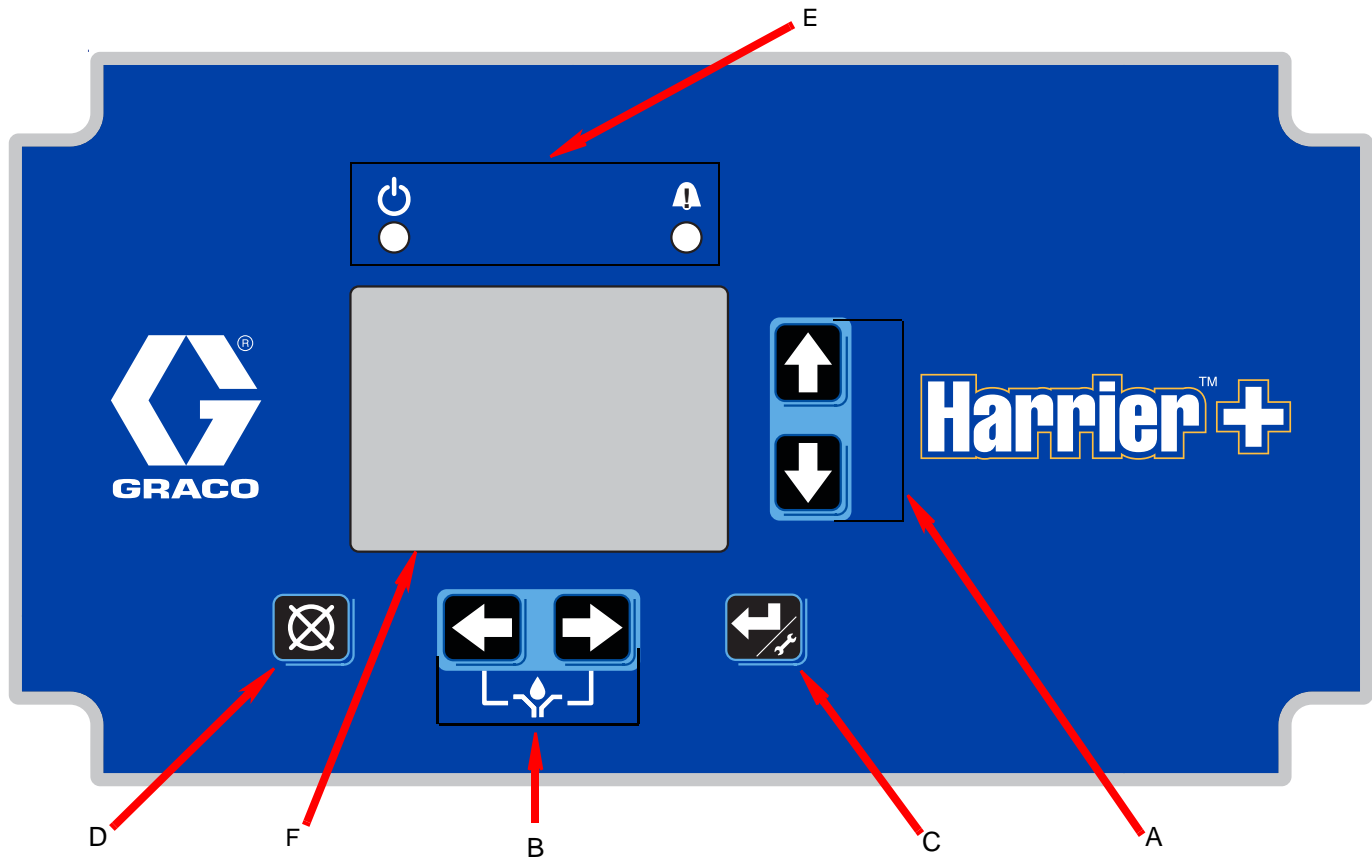
- Do not operate the unit when fatigued or under the influence of drugs or alcohol.
- Do not exceed the maximum working pressure or temperature rating of the lowest rated system component. See **Technical Data** in all equipment manuals.
- Use fluids and solvents that are compatible with equipment wetted parts. See **Technical Data** in all equipment manuals. Read fluid and solvent manufacturer's warnings. For complete information about your material, request Safety Data Sheet (SDS) from distributor or retailer.
- Turn off all equipment and follow the **Pressure Relief Procedure** when equipment is not in use.
- Check equipment regularly. Repair or replace worn or damaged parts immediately with genuine manufacturer's replacement parts only.
- Do not alter or modify equipment. Alterations or modifications may void agency approvals and create safety hazards.
- Make sure all equipment is rated and approved for the environment in which you are using it.
- Use equipment only for its intended purpose. Call your distributor for information.
- Route hoses and cables away from traffic areas, sharp edges, moving parts, and hot surfaces.
- Keep children and animals away from work area.
- Comply with all applicable safety regulations.

# Component Identification

## Keypad, Display, and Icons

**NOTICE**

To prevent damage to soft key buttons, do not press the buttons with sharp objects such as pens, plastic cards, or fingernails.



**FIG. 1: Harrier+ Keypad and Display**

### Run Mode Functions

#### Direction Arrows

- A Up and Down Arrow Keys:
- Navigate screen menus.
  - Increase or decrease values in numeric fields.
- B Left and Right Arrow Keys:
- Navigate screen menus.
  - Press both keys simultaneously to manually start a pump cycle or prime the pump.
  - Moves one digit to the left or right to edit numeric fields.

### Keypad Icons

**NOTE:** Keypad icons are described on page 7.

- C Enter Key: Press and hold for 3 seconds to access the Configuration screen (see FIG. 19, page 34). Also is used to save changes to setup fields (see **Setup Screens**, starting on page 34).
- D Reset Key: Resets unit to the pump run screen. Also is used to reset an alarm condition.
- E Function LED: See page 7 for a description of these icons.
- F Display

## Icons

The following icons are used throughout this instruction manual and on the Controller's Run and Setup Screens. Refer to this table if you are unsure of an icon's meaning.



**Power On indicator.** When power is supplied to the controller, Green LED illuminates under Function Icon located above the display screen.



**Pump On indicator.** Displayed on right side of Pump Run screen during the Pump On cycle.



**Pump Off indicator.** Displayed on right side of Run screen during the Pump Off cycle.



**Setup Mode active.** Displayed on the upper right corner of the Configuration screen.



**Time Mode active.** Displayed on top right side of screen when the Time Run screen is displayed.



**Cycle count Mode active.** Displayed on top right side of the display screen when the Cycle Run screen is displayed.



**Alarm active.** Red LED illuminates under the Function LED located above the display screen when an alarm event occurs.



**Flow Mode active.** Displayed on the top right side of the display screen when the Flow Run screen is displayed.



**Signal Strength.** Displayed on the Network screen when Cell is selected and cell signal detected.



**DC Voltage.** Displayed next to the battery voltage on the left side of Run screen. (Applies to DC models only.)



**Pressure.** Displayed next to the pressure reading on the left side of Run screen.



**Tank Level.** Displayed next to the tank level reading on the left side of Run screen.



**Temperature.** Displayed next to the temperature reading on the left side of the Run screen. The temperature is measured by the temperature probe.





# Installation

## Installing the Injection Controller

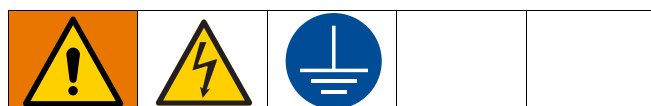


### AUTOMATIC SYSTEM ACTIVATION HAZARD

Unexpected activation of the system could result in serious injury, including skin injection and amputation.

This device has an automatic timer that activates the chemical injection system when power is connected or when exiting the programming function. The device can also be activated remotely from internet portals. Before you install or remove the controller from the system, disconnect and isolate all power supplies, and relieve all pressure.

1. Select a flat surface to install the Injection Controller. Refer to **Dimensions and Mounting Hole Layout** on page 75.



All electrical wiring must be done by a qualified electrician and comply with all local codes and regulations.

Opening the controller to remove the screws that attach the mounting plate to the controller may expose the assembler to live voltage. Do not remove the mounting plate.

2. Align the mounting surface with predrilled holes on mounting plate. Use mounting studs (provided) with two 1/4-20 nuts (not provided).

### NOTICE

Use only designated mounting plates and holes in controller enclosure. Do not drill additional mounting holes, or short wires together, as it can cause circuit board damage.

## Grounding



The equipment must be grounded to reduce the risk of static sparking and electric shock. Electric or static sparking can cause fumes to ignite or explode. Improper grounding can cause electric shock. Grounding provides an escape wire for the electric current.

### Controller:

**DC models** - ground the controller by attaching the mounting bracket to a grounded surface.

**AC models** - ground the controller by attaching the ground wire from the harness to a true earth ground.

## Antenna Connection



Removing or replacing the antenna while the circuit is live may spark ignitable fumes in the area. To reduce the risk of ignition, do not remove or replace the antenna while the circuit is live unless the area is free of ignitable fumes.

## Typical 12 or 24 VDC Installation and Wiring

FIG. 2 is an example of 12 or 24 VDC installation. Your installation may differ from what is shown here. The Harrier+ controller (G), with wiring, is supplied by Graco. All other components are supplied by the customer. Contact your Graco distributor for assistance in planning a system to suit your needs.

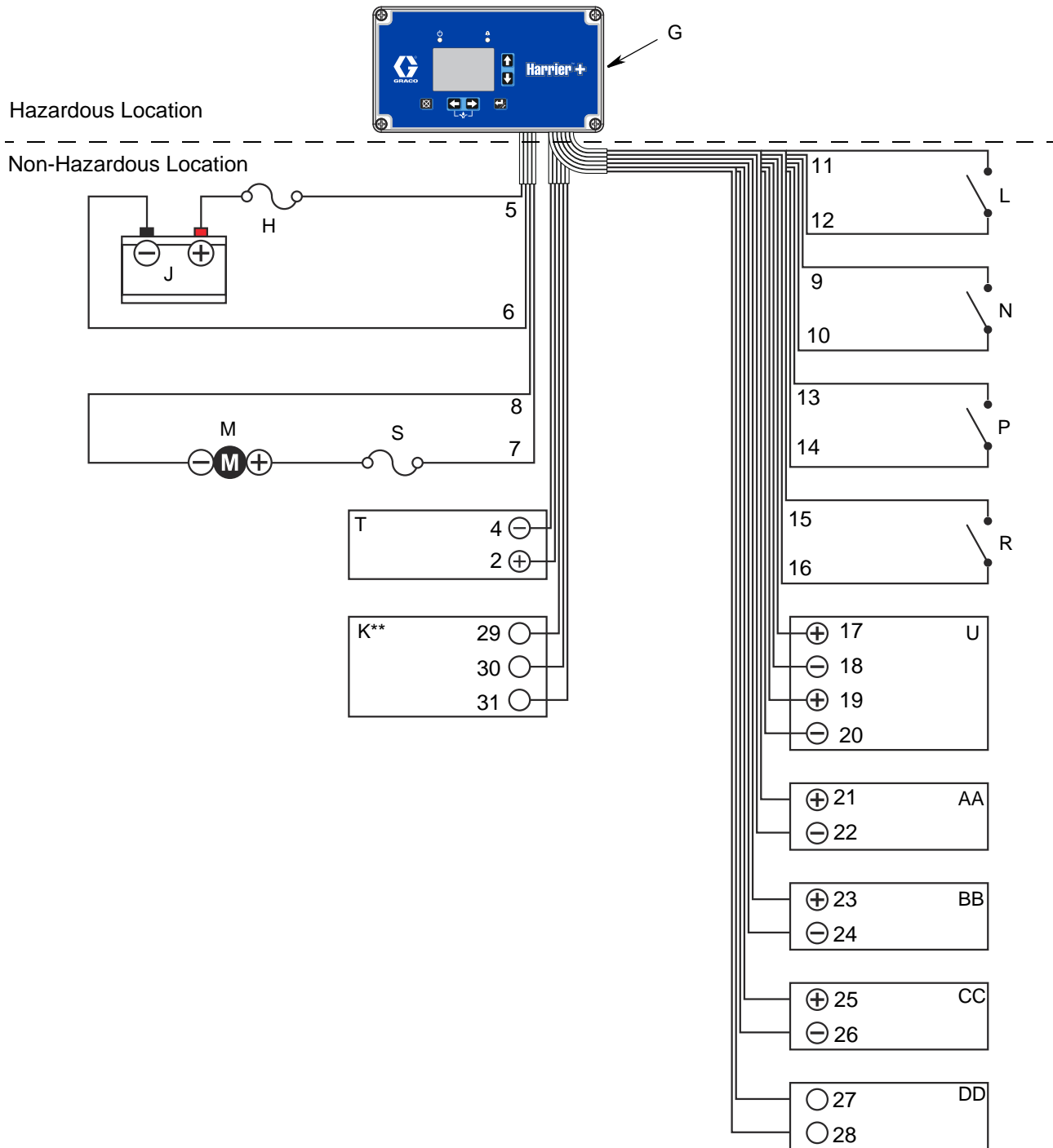


FIG. 2: Typical 12 or 24 VDC Installation

**Key:**

<b>G</b>	Controller
<b>H</b>	In-line Fuse* (battery) - UL 248 approved, 30A max (DC)
<b>J</b>	Battery (12 or 24 VDC)
<b>K</b>	RS232 SCADA Interface** (optional, SCADA models only)
<b>L</b>	Auxiliary Switch (optional)
<b>M</b>	Pump Motor
<b>N</b>	Cycle Counter for System Control
<b>P</b>	Alarm Input #1 (optional)
<b>R</b>	Alarm Input #2 (optional)
<b>S</b>	In-line Fuse* (pump) - UL 248 approved, 30A max*** (DC)
<b>T</b>	Battery Monitor (optional)
<b>U</b>	Pressure Transducer (optional)
<b>AA</b>	Tank Level Monitor (optional)
<b>BB</b>	Analog In (optional)
<b>CC</b>	Analog Out (optional)
<b>DD</b>	Temperature Probe (optional)

\* *UL 248 approved fuses are to be provided by the user.*

\*\* *RS232 communication is available on SCADA models. Gateway adapters to the controller's RS232 interface must be provided by user to support other protocols.*

\*\*\* *Sized according to motor nameplate amperage.*

## 12 or 24 VDC Wiring Diagram

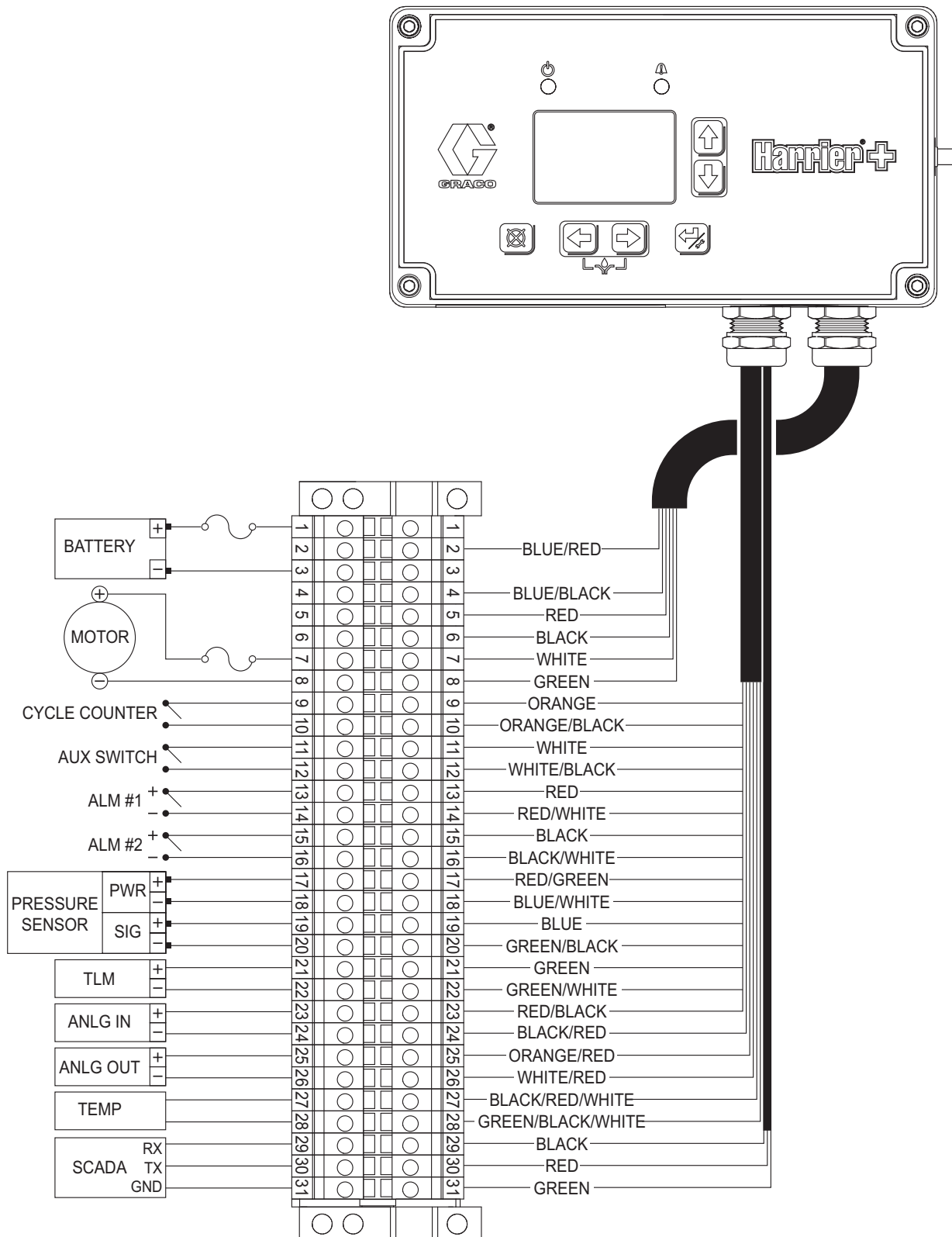


FIG. 3: 12 or 24 VDC Wiring

**Wiring Key:**

1	Battery (+)	Jumper (not shown) Harrier+ no connect.
2	Battery Monitor (+)	blue/red
3	Battery (-)	Jumper (not shown) Harrier+ no connect.
4	Battery Monitor (-)	blue/black
5	Controller (+)	red
6	Controller (-)	black
7	Pump Motor (+)	white
8	Pump Motor (-)	green
9	Cycle Counter (+)	orange
10	Cycle Counter (-)	orange/black
11	Auxiliary Switch (+)	white
12	Auxiliary Switch (-)	white/black
13	Alarm #1 (+)	red
14	Alarm #1 (-)	red/white
15	Alarm #2 (+)	black
16	Alarm #2 (-)	black/white
17	Pressure Transducer Power (+)	red/green
18	Pressure Transducer Power (-)	blue/white
19	Pressure Transducer Signal (+)	blue
20	Pressure Transducer Signal (-)	green/black
21	Tank Level Monitor (+)	green
22	Tank Level Monitor (-)	green/white
23	Analog In (+)	red/black
24	Analog In (-)	black/red
25	Analog Out (+)	orange/red
26	Analog Out (-)	white/red
27	Temperature Probe	black/red/white
28	Temperature Probe	green/black/white
29	SCADA (RX)	black
30	SCADA (TX)	red
31	SCADA (GND)	green

## Typical 120 VAC Installation and Wiring

FIG. 4 is an example of 120 VAC installation. Your installation may differ from what is shown here. The Harrier+ controller (G), with wiring, is supplied by Graco. All other components are supplied by the customer. Contact your Graco distributor for assistance in planning a system to suit your needs.

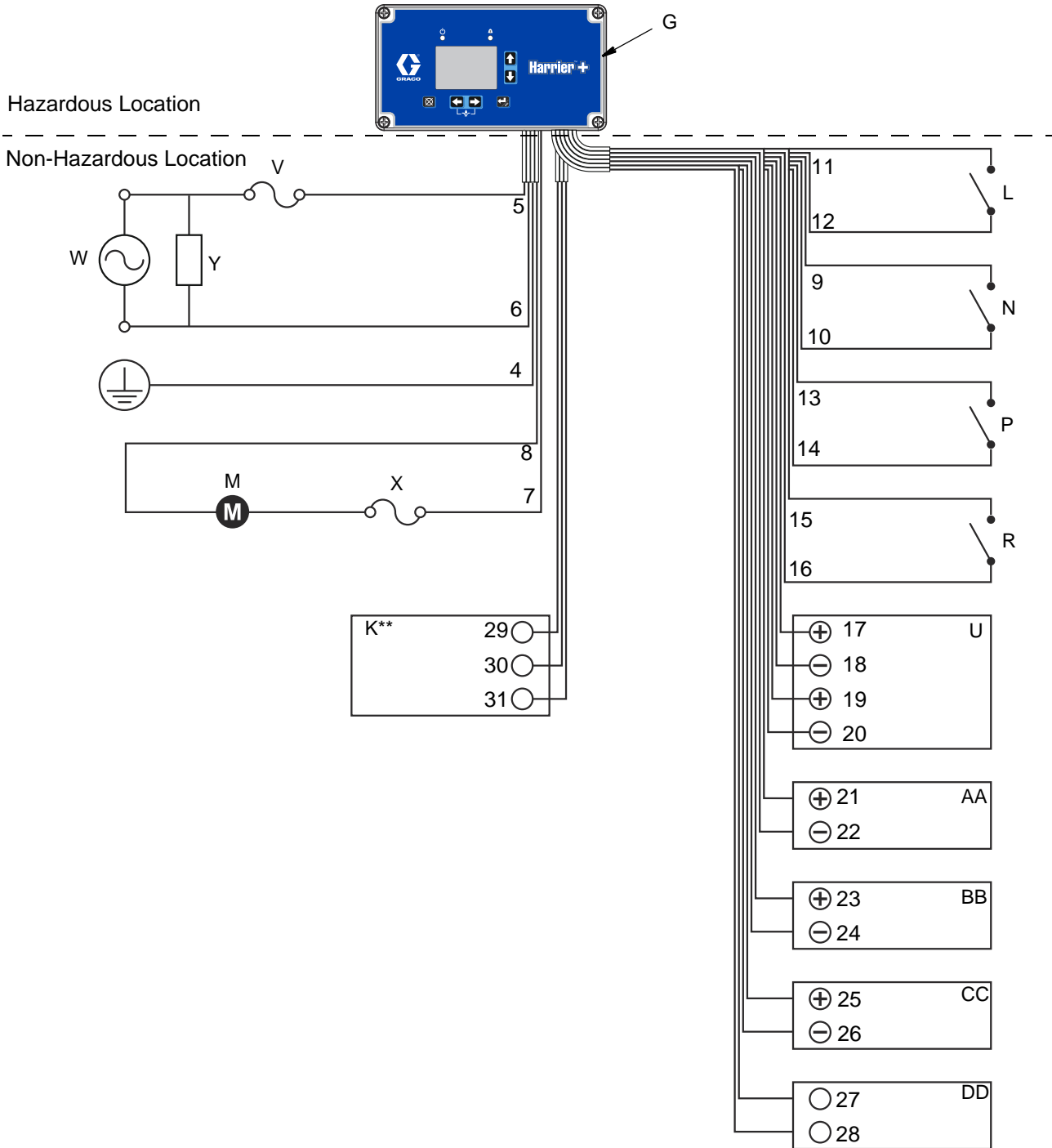


FIG. 4: Typical 120 VAC Installation

**Key:**

<b>G</b>	Controller
<b>K</b>	RS232 SCADA Interface** (optional, SCADA models only)
<b>L</b>	Auxiliary Switch (optional)
<b>M</b>	Pump Motor
<b>N</b>	Cycle Counter for System Control
<b>P</b>	Alarm Input #1 (optional)
<b>R</b>	Alarm Input #2 (optional)
<b>U</b>	Pressure Transducer (optional)
<b>V</b>	In-line Fuse* (line) - UL 489, Class CC approved, 5A max (AC)
<b>W</b>	Line Power (120 VAC)
<b>X</b>	In-line Fuse* (line) - UL 489, Class CC approved, 5A max (AC)
<b>Y</b>	Surge Protection Device***
<b>AA</b>	Tank Level Monitor (optional)
<b>BB</b>	Analog In (optional)
<b>CC</b>	Analog Out (optional)
<b>DD</b>	Temperature Probe (optional)

\* UL 489 approved fuses are to be provided by the user.

\*\* RS232 communication is available on SCADA models. Gateway adapters to the controller's RS232 interface must be provided by user to support other protocols.

\*\*\* Type 1, Maximum recommended clamping voltage:

Line-Line: 1500V

Line-Neutral: 1000V

Max surge current  $\geq 25kA$

(Required for CE)

### 120 VAC Wiring Diagram

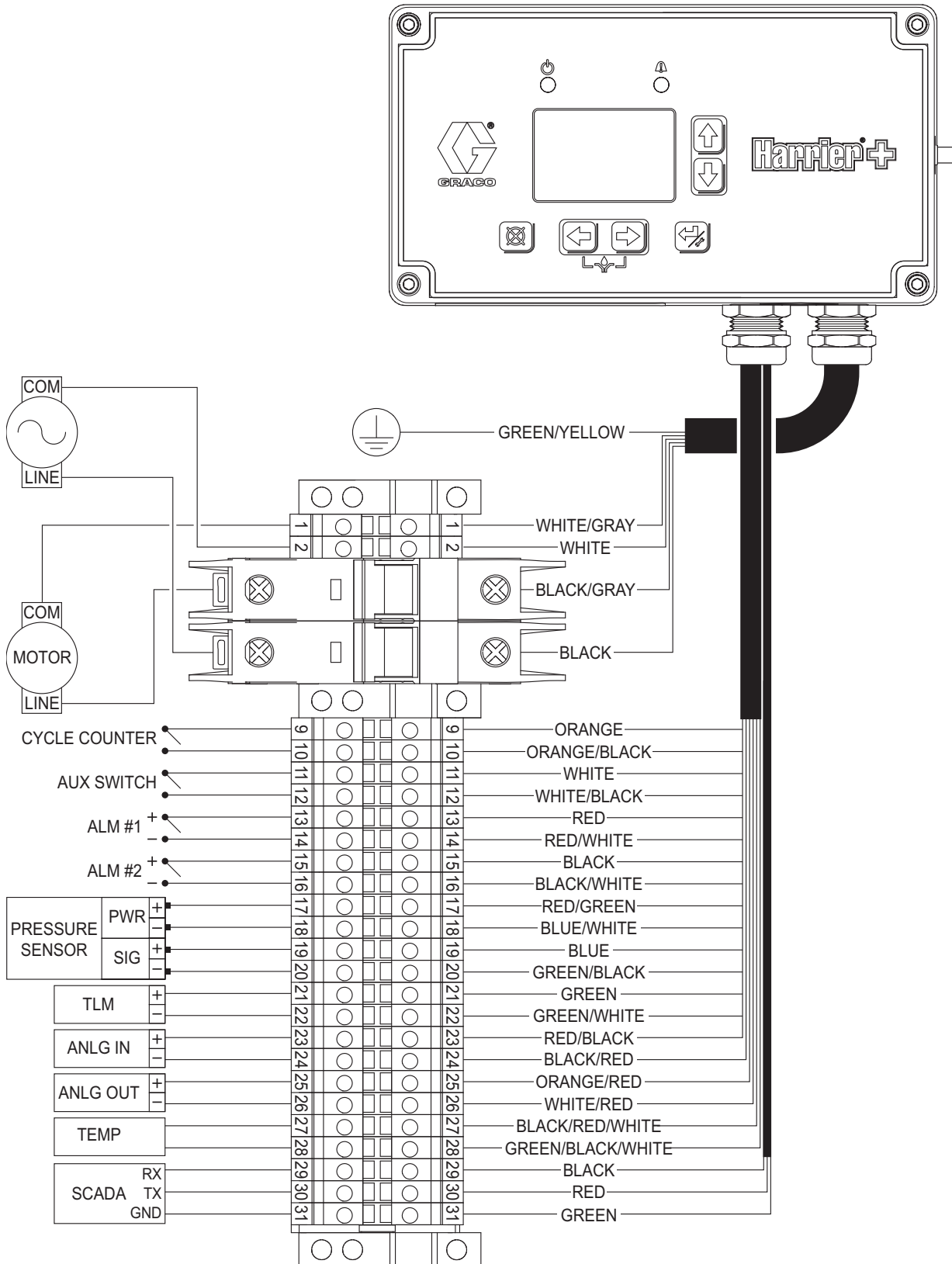


Fig. 5: 120 VAC Wiring Diagram



**Wiring Key:**

<b>1</b>	Motor COM	white/gray
<b>2</b>	AC COM	white
<b>B1</b>	Motor LINE Breaker	black/gray
<b>B2</b>	AC LINE Breaker	black
<b>9</b>	Cycle Counter (+)	orange
<b>10</b>	Cycle Counter (-)	orange/black
<b>11</b>	Auxiliary Switch (+)	white
<b>12</b>	Auxiliary Switch (-)	white/black
<b>13</b>	Alarm #1 (+)	red
<b>14</b>	Alarm #1 (-)	red/white
<b>15</b>	Alarm #2 (+)	black
<b>16</b>	Alarm #2 (-)	black/white
<b>17</b>	Pressure Transducer Power (+)	red/green
<b>18</b>	Pressure Transducer Power (-)	blue/white
<b>19</b>	Pressure Transducer Signal (+)	blue
<b>20</b>	Pressure Transducer Signal (-)	green/black
<b>21</b>	Tank Level Monitor (+)	green
<b>22</b>	Tank Level Monitor (-)	green/white
<b>23</b>	Analog In (+)	red/black
<b>24</b>	Analog In (-)	black/red
<b>25</b>	Analog Out (+)	orange/red
<b>26</b>	Analog Out (-)	white/red
<b>27</b>	Temperature Probe	black/red/white
<b>28</b>	Temperature Probe	green/black/white
<b>29</b>	SCADA (RX)	black
<b>30</b>	SCADA (TX)	red
<b>31</b>	SCADA (GND)	green

## Typical 240 VAC Installation and Wiring

FIG. 6 is an example of 240 VAC installation. Your installation may differ from what is shown here. The Harrier+ controller (G), with wiring, is supplied by Graco. All other components are supplied by the customer. Contact your Graco distributor for assistance in planning a system to suit your needs.

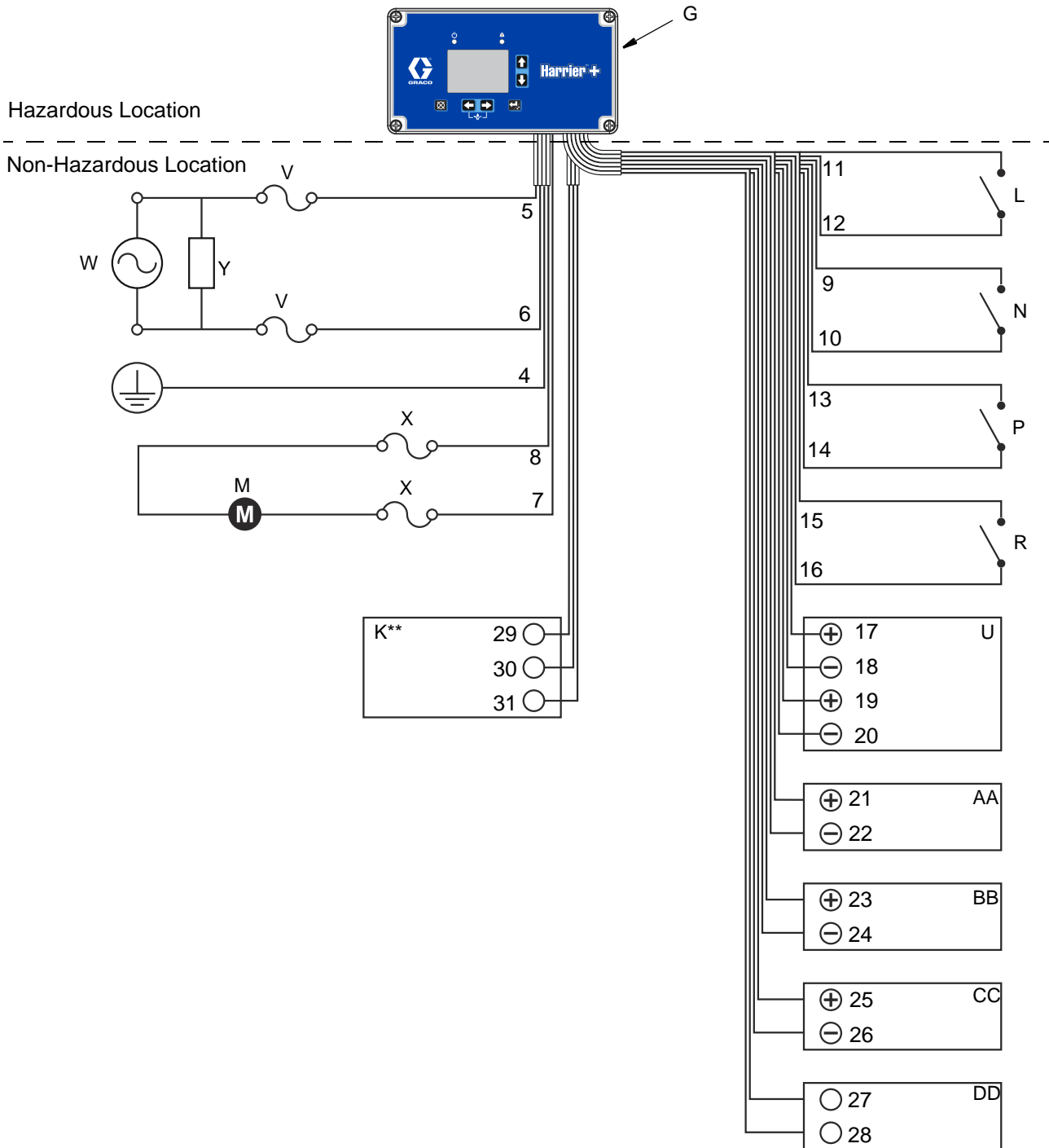


FIG. 6: Typical 240 VAC Installation

**Key:**

<b>G</b>	Controller
<b>K</b>	RS232 SCADA Interface** (optional, SCADA models only)
<b>L</b>	Auxiliary Switch (optional)
<b>M</b>	Pump Motor
<b>N</b>	Cycle Counter for System Control
<b>P</b>	Alarm Input #1 (optional)
<b>R</b>	Alarm Input #2 (optional)
<b>U</b>	Pressure Transducer (optional)
<b>V</b>	In-line Breaker (line) - UL 489, Class CC approved, 3A max (AC)
<b>X</b>	In-line Breaker (line) - UL 489, Class CC approved, 3A max (AC)
<b>Y</b>	Surge Protection Device***
<b>Z</b>	Line Power (240 VAC)
<b>AA</b>	Tank Level Monitor (optional)
<b>BB</b>	Analog In (optional)
<b>CC</b>	Analog Out (optional)
<b>DD</b>	Temperature Probe (optional)

\*\* RS232 communication is available on SCADA models. Gateway adapters to the controller's RS232 interface must be provided by user to support other protocols.

\*\*\* Type 1, Maximum recommended clamping voltage:  
 Line-Line: 1500V  
 Line-Neutral: 1000V  
 Max surge current >= 25kA  
 (Required for CE)

## 240 VAC Wiring Diagram

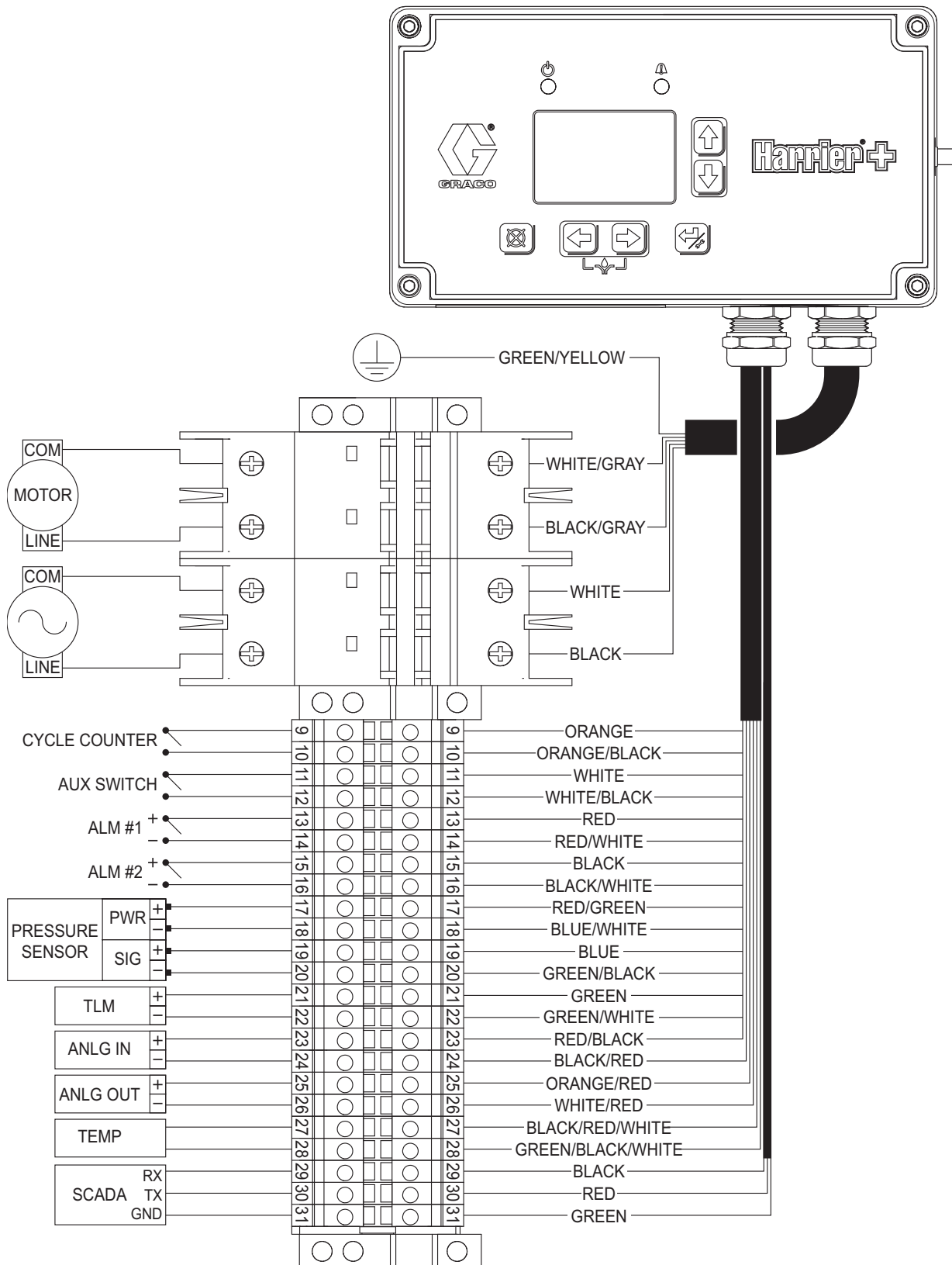


FIG. 7: 240 VAC Wiring Diagram

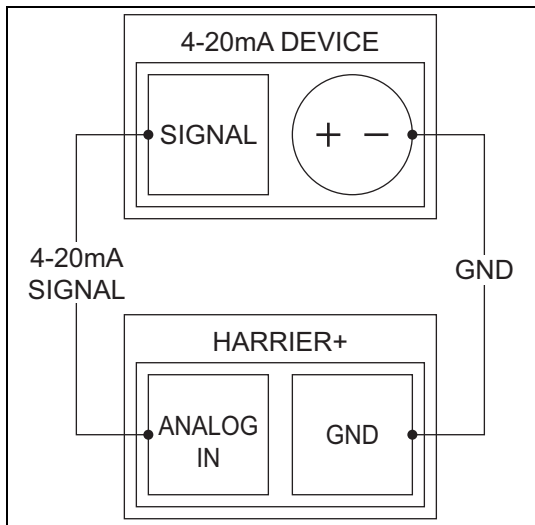
**Wiring Key:**

<b>B1</b>	Motor COM Breaker	white/gray
<b>B2</b>	Motor LINE Breaker	black/gray
<b>B3</b>	AC COM Breaker	white
<b>B4</b>	AC LINE Breaker	black
<b>4</b>	Earth Ground	green/yellow
<b>5</b>	Controller (LINE)	black
<b>6</b>	Controller (COM)	white
<b>7</b>	Pump Motor (LINE)	black/gray
<b>8</b>	Pump Motor (COM)	white/gray
<b>9</b>	Cycle Counter (+)	orange
<b>10</b>	Cycle Counter (-)	orange/black
<b>11</b>	Auxiliary Switch (+)	white
<b>12</b>	Auxiliary Switch (-)	white/black
<b>13</b>	Alarm #1 (+)	red
<b>14</b>	Alarm #1 (-)	red/white
<b>15</b>	Alarm #2 (+)	black
<b>16</b>	Alarm #2 (-)	black/white
<b>17</b>	Pressure Transducer Power (+)	red/green
<b>18</b>	Pressure Transducer Power (-)	blue/white
<b>19</b>	Pressure Transducer Signal (+)	blue
<b>20</b>	Pressure Transducer Signal (-)	green/black
<b>21</b>	Tank Level Monitor (+)	green
<b>22</b>	Tank Level Monitor (-)	green/white
<b>23</b>	Analog In (+)	red/black
<b>24</b>	Analog In (-)	black/red
<b>25</b>	Analog Out (+)	orange/red
<b>26</b>	Analog Out (-)	white/red
<b>27</b>	Temperature Probe	black/red/white
<b>28</b>	Temperature Probe	green/black/white
<b>29</b>	SCADA (RX)	black
<b>30</b>	SCADA (TX)	red
<b>31</b>	SCADA (GND)	green

# Wiring Diagrams

## Analog In Powered Wiring

Installation instructions for connecting the ANALOG IN signal to a powered 4-20mA device where the device provides power.

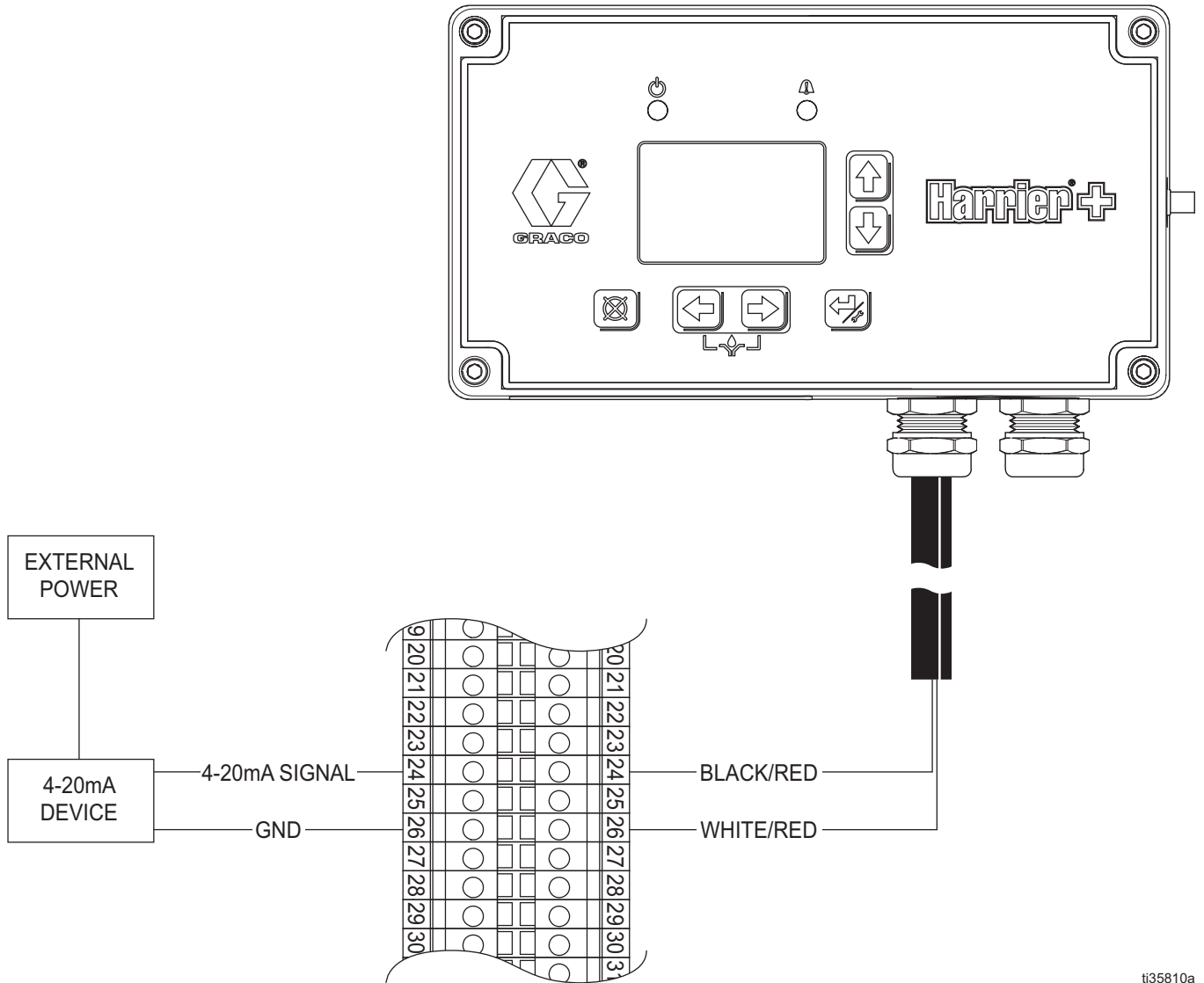


**FIG. 8: Loop Diagram, Device Provides Power**

Some 4-20mA devices are powered, as shown in FIG. 8. For powered devices, only the 4-20mA in/out signal needs to be connected to the analog input on the Harrier+, and the other process signal loop wire connects to GND.

Disconnect power to the controller and motor before wiring anything.

1. Connect the positive terminal of the device supplying the signal to terminal 24 "Analog In (-)".
2. Connect the negative terminal of the device supplying the signal to terminal 26 "Analog out (-)" (an unused GND).



ti35810a

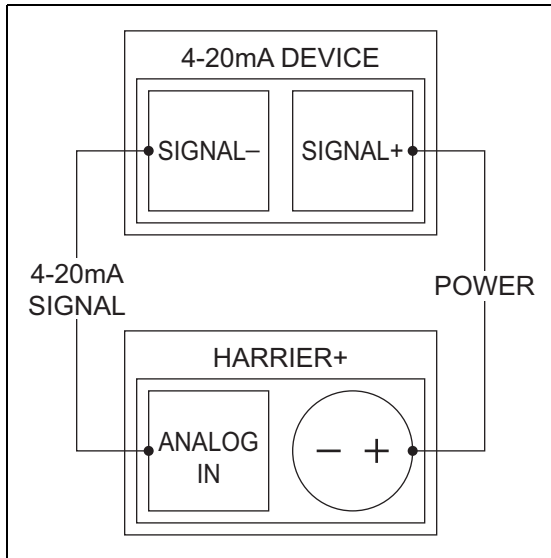
**FIG. 9: Powered Device, use terminals 24 and 26**

**Wiring Key:**

<b>24</b>	Analog In (-)	black/red
<b>26</b>	Analog Out (-) / GND	white/red

## Analog In Non-Powered Wiring

Installation instructions for connecting the ANALOG IN signal to a non-powered 4-20mA device where the Harrier+ provides power.



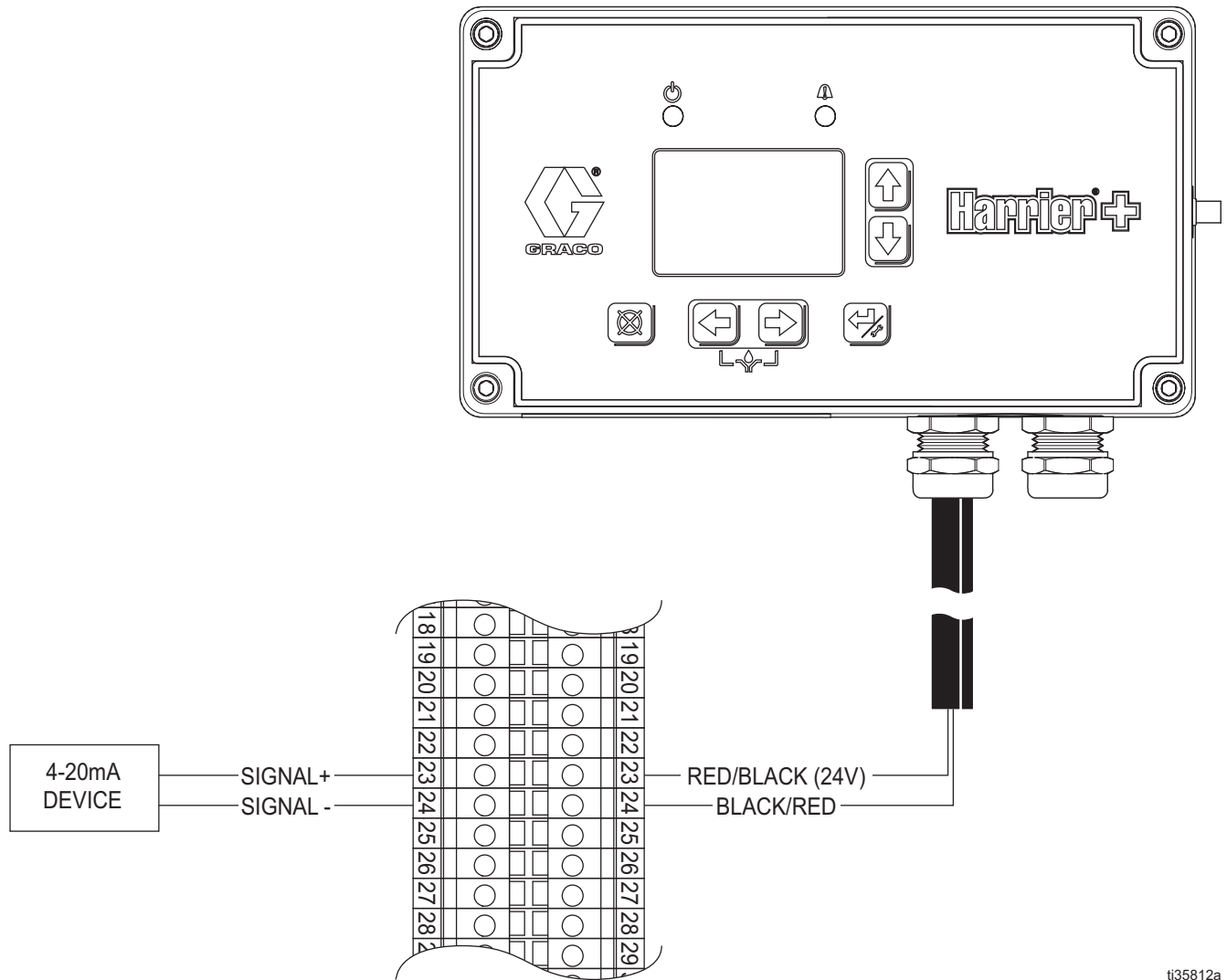
**Fig. 10: Loop Diagram, Harrier+ Provides Power**

Some 4-20mA devices are not powered and draw power from the process signal loop. For non-powered devices, the Harrier+ provides 24V on the Analog In (+) terminal to the device's signal+ line. The device's signal- line is then connected to the Harrier+ Analog In (-) terminal.

Disconnect the power to the controller and motor before wiring anything.

1. Connect the signal + terminal of the device supplying the signal to terminal 23 "Analog In (+)" (24V).
2. Connect the signal - terminal of the device supplying the signal to terminal 24 "Analog In (-)" (signal input).







ti35812a

**FIG. 11: Non-Powered Device, use terminals 23 and 24**

**Wiring Key:**

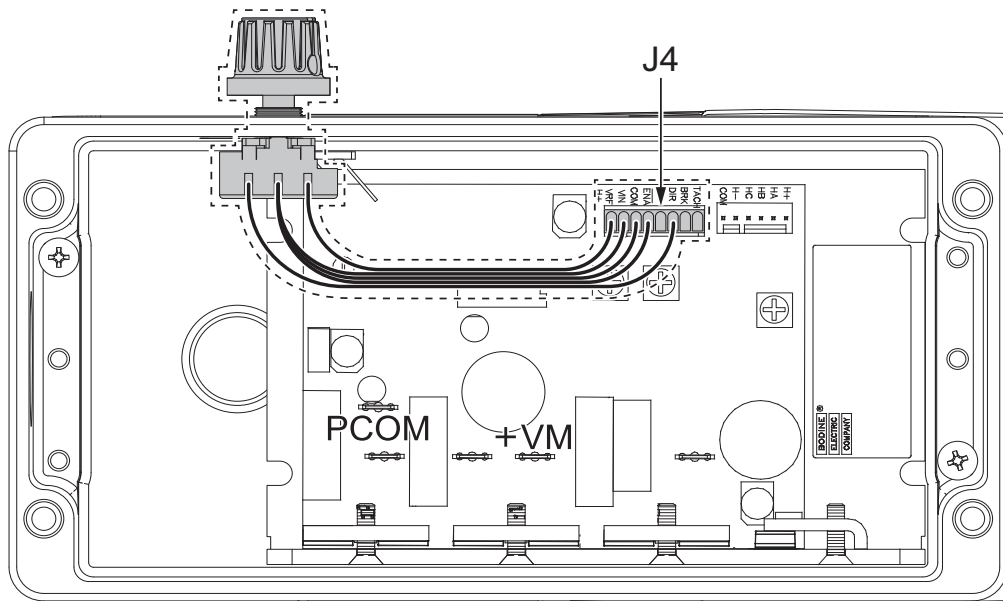
<b>23</b>	Analog In (+) / 24V	red/black
<b>24</b>	Analog In (-)	black/red

## Analog Out DC Pump Wiring With Kit (B33006)

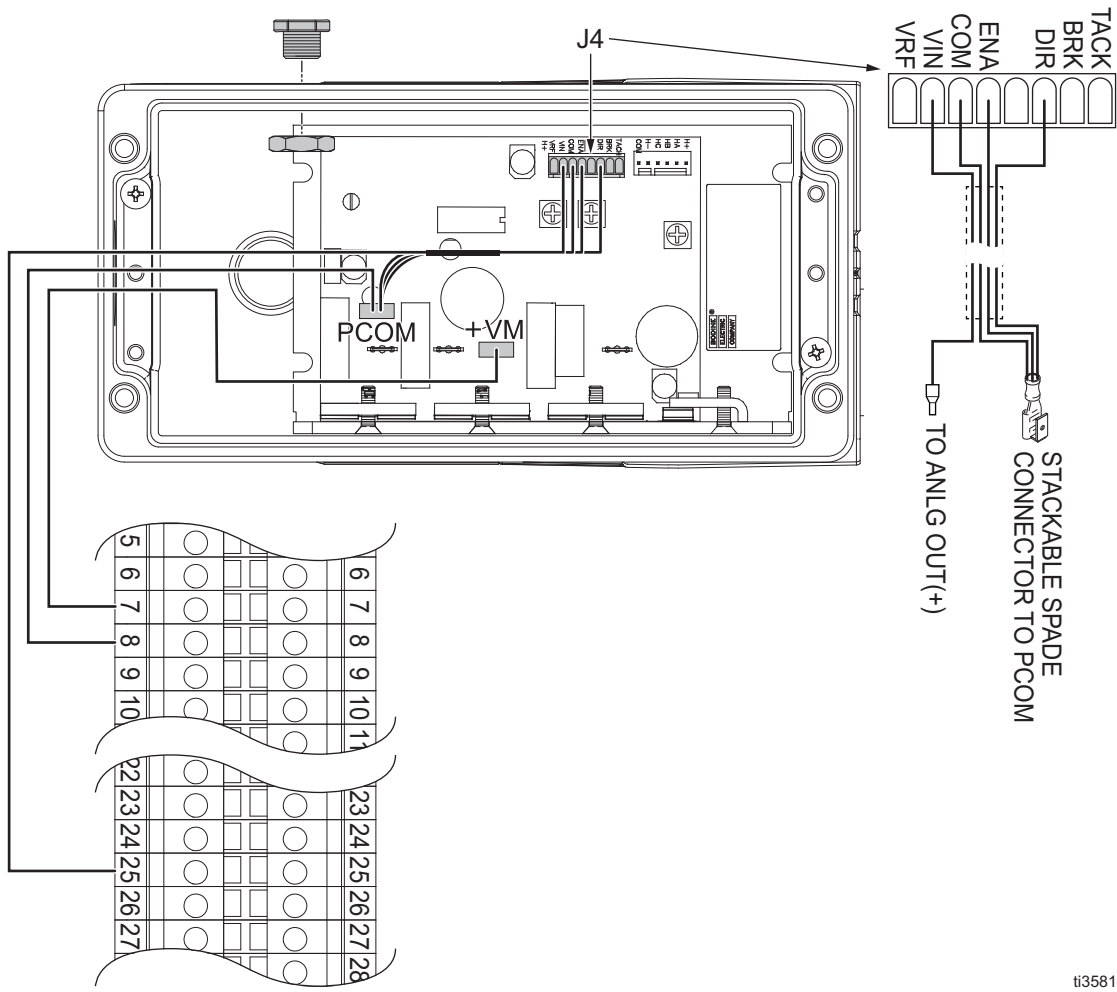
				
<p>For remote operation of these products in a Class I, Division 2, Groups A, B, C, or D hazardous environment, please review your local safety rules and regulations.</p>				

DC Motor Only - Installation instructions for connecting the ANALOG OUT signal to a DC variable speed motor using Kit B33006.

1. Disconnect power to the variable speed Wolverine Motor.
2. Remove the motor junction box cover.
3. Remove the potentiometer knob and 8-pin white connector wire harness assembly, connected to J4, shown in FIG. 12.
4. Use the B33006 kit supply's plug to seal the hole in the junction box left behind by removing the potentiometer knob. See **DC Motor Only. Connect Harrier+ Analog Out to DC Variable Speed Motor with Kit B33006** FIG. 13.
5. Connect the B33006 wiring harness 8-pin white connector into the variable speed board on J4.
6. Connect the 3-wire yellow stackable spade connector from J4 to the variable speed board PCOM terminal.
7. Connect pump motor(-) (8) from the Harrier+ terminal block to the yellow stackable spade connector at the variable speed board PCOM terminal.
8. Connect pump motor(+) (7) from the Harrier+ terminal block to the variable speed board +VM terminal.
9. Connect the single wire on the B33006 wiring harness to Analog Out(+) (25) on the Harrier+ terminal block.



**FIG. 12: Bodine DC Variable Speed Board with Potentiometer Knob**



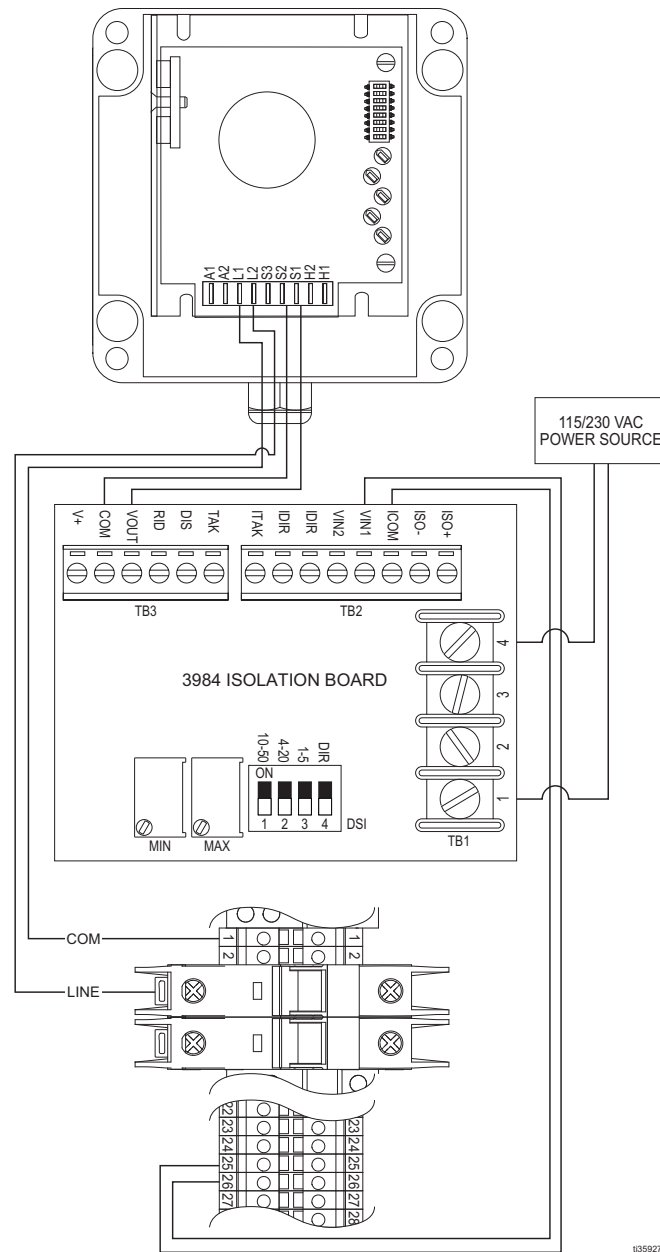
ti35814a

**FIG. 13: DC Motor Only. Connect Harrier+ Analog Out to DC Variable Speed Motor with Kit B33006**

**Wiring Key:**

7	Pump Motor (+)	white
8	Pump Motor (-)	green
25	Analog Out (+)	orange/red





135927a

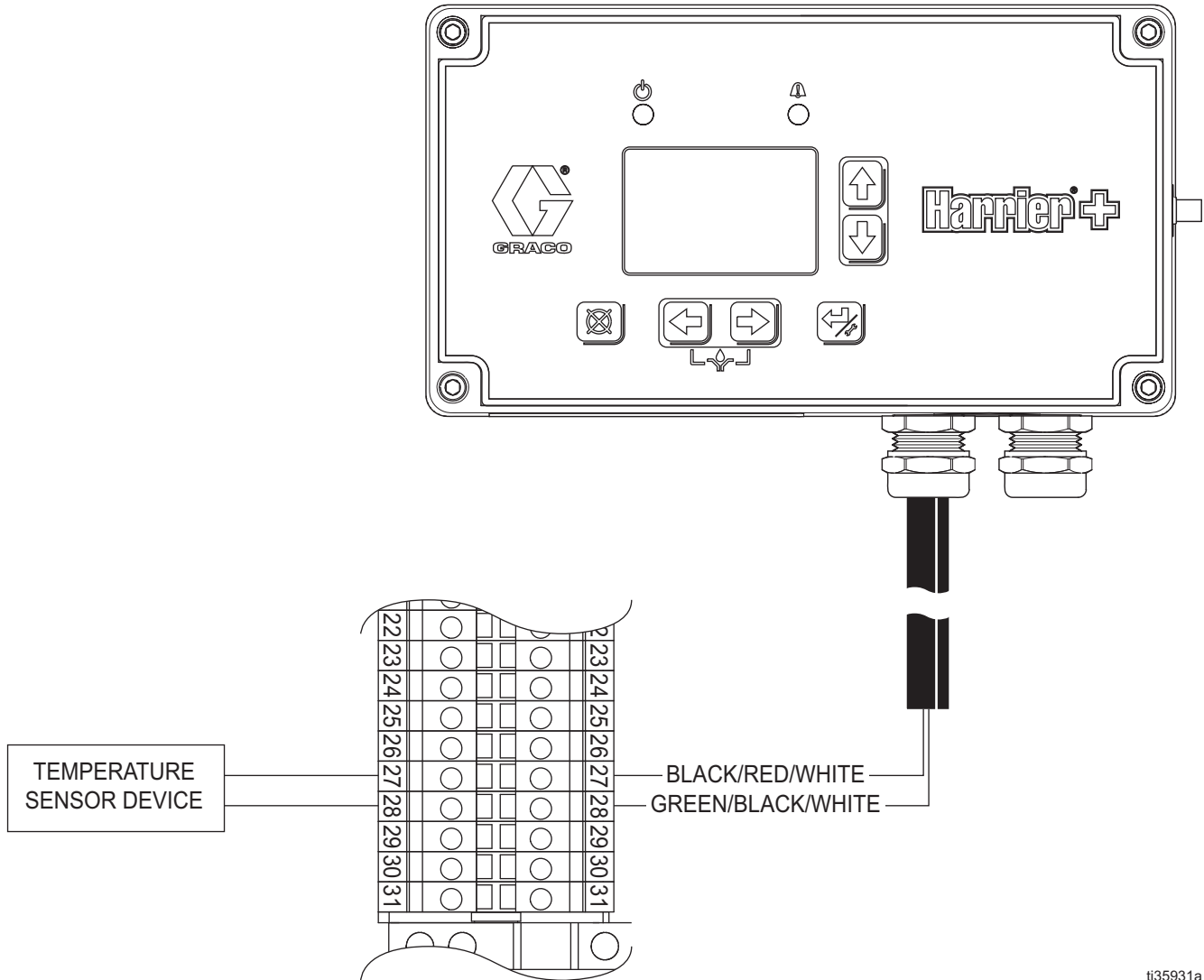
**FIG. 15: AC 120 VAC Motor Only. Connect Harrier+ Analog Out To The DC Variable Speed Motor With An Isolation Board.**

**Wiring Key:**

1	Pump Motor (COM)	black/gray
B1	Pump Motor (LINE)	white/gray
25	Analog Out (+)	orange/red
26	Analog Out (-)	white/red

## Temperature Control Wiring

1. Mount the temperature sensor device lug or probe in the desired location. Lug Style (Kit B32989) or Probe Style (Kit B32131).
2. Connect the temperature sensor leads to terminals 27 and 28 on the din rail (polarity does not matter).



**FIG. 16: Temperature Control Wiring**

ti35931a

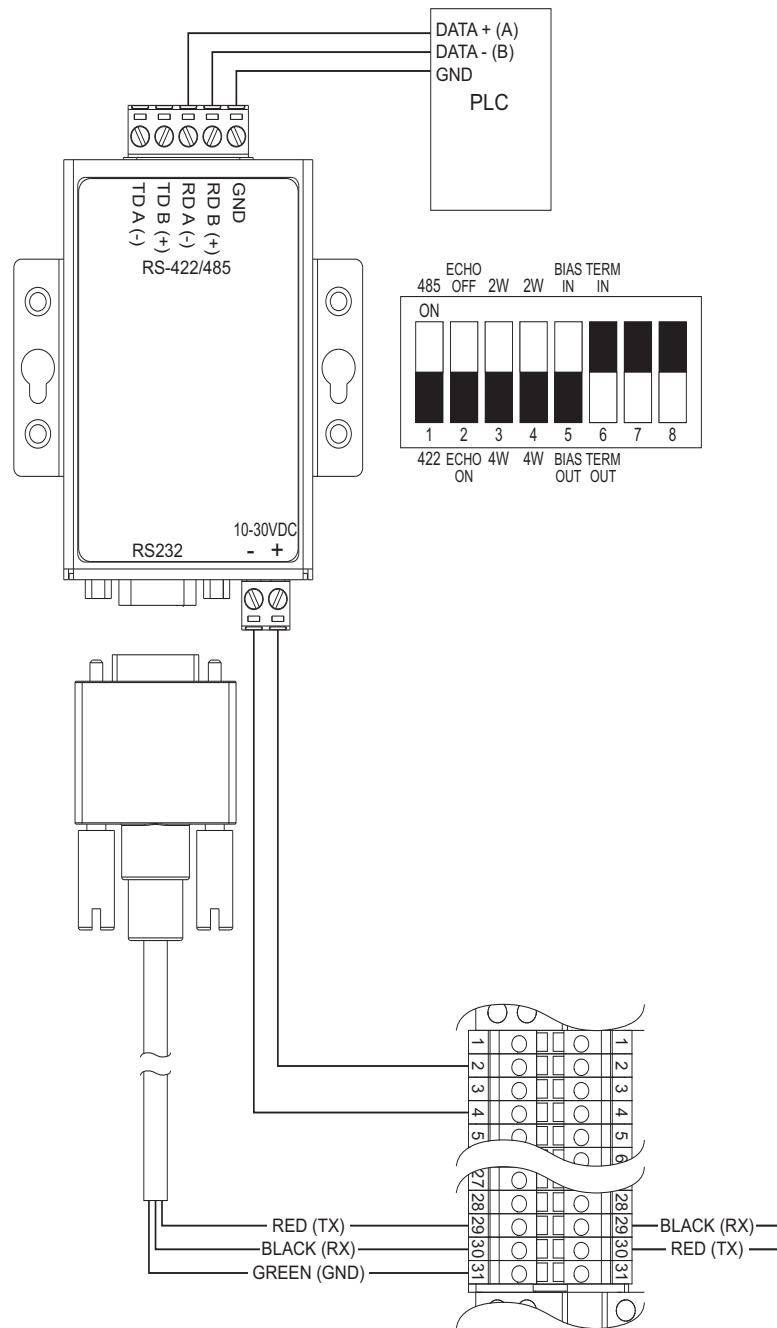
### Wiring Key:

27	Temperature Probe	black/red/white
28	Temperature Probe	green/black/white

## Scada Wiring for RS232 to RS485 Converter Kit (B32874)

This is an example of connecting a 2-wire RS485 device to a PLC. It uses the internal bias resistance of the converter and assumes that the external RS485 network provides its own termination resistance. Bias and termination settings may vary depending on the application, especially if multiple devices are connected. It's recommended to begin with the default switch settings shown and with just one Harrier+ connected until communication is established.

1. Connect the RX, TX, and GND wires on the supplied cable in Kit B32874 to the RX, TX, and GND Harrier+ terminal blocks (terminal numbers may vary). Cross the RX and TX lines, RX to TX and TX to RX on the din rail.
2. Connect the + and - power terminals on the converter to a 10-30V power source, such as the + and - battery terminals 2 and 4 respectively. AC systems must supply their own 10-30V power supply.
3. Connect the RS485 RDB (+), RDA (-), and GND terminals to the appropriate PLC inputs.
4. Keep the 8-Position DIP switches on the back of the converter in their default configuration, as shown.



**Fig. 17: Scada Wiring**

**Wiring Key:**

2	Battery Monitor (+)*	blue/red
4	Battery Monitor (-)*	blue/black
29	Scada (Rx)	black
30	Scada (Tx)	red
31	Scada (GND)	green

*\*AC Systems must supply their own 10-30V Power Supply*



# Theory of Operation

## Flow Control Summary

In Flow mode, you can choose a target flow rate, in gallons or liters per day, and the controller will determine how long it needs to run the pump to hit that flow rate. The maximum volume that can be pumped each day is determined by the pump's plunger diameter and stroke length and is represented as the K-Factor. The K-Factor can be dialed in during calibration for maximum accuracy.

Flow mode is advantageous when maximum accuracy is required. It is the most accurate mode because it can be precisely calibrated and compensates for changes in the application such as well pressure and battery voltage.

## Cycle Control Summary

In Cycle mode, you can choose the number of cycles the pump runs for and the off time. A cycle is a single rotation of the pump cam, as detected by the cycle switch.

Cycle mode is advantageous when accuracy is required without having to calibrate the system. It provides assurance that an exact number of cycles are dispensed before the pump stops for the duration of the off time. Although not required, it's recommended to use a calibration column to verify the volume dispensed.

## Time Control Summary

In Time mode, you can choose the on time and off time. Adjusting the on and off times allows the user to control both the dosing of chemical along with the frequency at which the pump runs.

Time mode is advantageous when direct control of the pump's run time is required.

## Pump Calibration

The pump should be calibrated to ensure the accuracy of the actual flow rate and totalizers. The totalizers are reported on the Web portal in Flow Mode.

### Calibration Column Method

This method requires the user to provide a calibration column that can be isolated from the tank. Fluid is pumped from the column and measured to dial in the K-Factor. It's the most accurate method for dialing in the K-Factor and is required to run a pump in flow mode. See kit B32088 or B32208.

Set up the controller in Flow Mode by following steps 1-18 on the **Pump Setup Screen (Flow Mode)**, page 34, and complete the Calibration Column Method, page 36, described in steps 19-25.


If desired, a calibration column can also be used to verify the volume dispensed after setting up the controller in Cycle Mode (See **Pump Setup Screen (Cycle Mode)**, page 37).

### Beaker Method

This method requires the user to provide an appropriately sized beaker based on the size and flow rate of the pump. Fluid is dispensed into the beaker and measured to automatically calculate an estimated K-Factor for increased injection accuracy. It is only intended for use in low pressure applications where the pressure is at or near 0 psi.

Set up the controller in Flow Mode by following steps 1-18 on the **Pump Setup Screen (Flow Mode)**, page 34, and replace the calibration column steps 19-25 with the Beaker Calibration procedure, initiated on the Advanced Setup Screen (See **Beaker Calibration Method**, page 46).

# Controller Setup



**AUTOMATIC SYSTEM ACTIVATION HAZARD**

Unexpected activation of the system could result in serious injury, including skin injection and amputation.

This device can automatically dispense fluid as soon as it is returned to the Run screen (see page 51).

2. Use the Up/Down arrows to move the cursor up and down through the list of setup screens, and press Enter to display the selected setup screen.
3. When all setup operations are complete, press Reset to return to normal operation.

## Configuration Screen

When you first turn on power to the Injection Controller, the following identification screen displays.



Fig. 18: Splash screen

AA The current Software Version

**NOTE:** The backlight is on at power-up and will turn off after 30 seconds if no button is pressed.

1. To access the Configuration screen, press and hold the Enter key for 3 seconds.

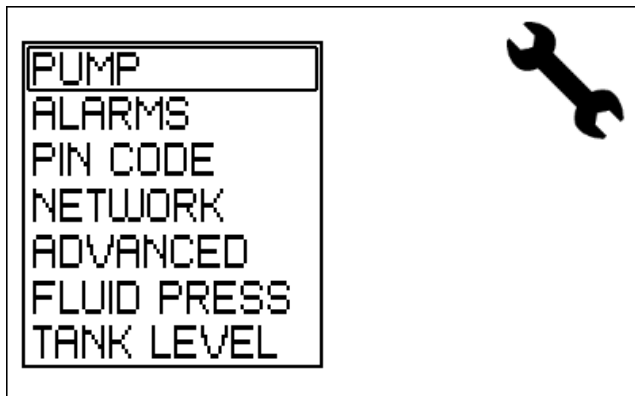


Fig. 19: Configuration screen

## Pump Setup Screen (Flow Mode)

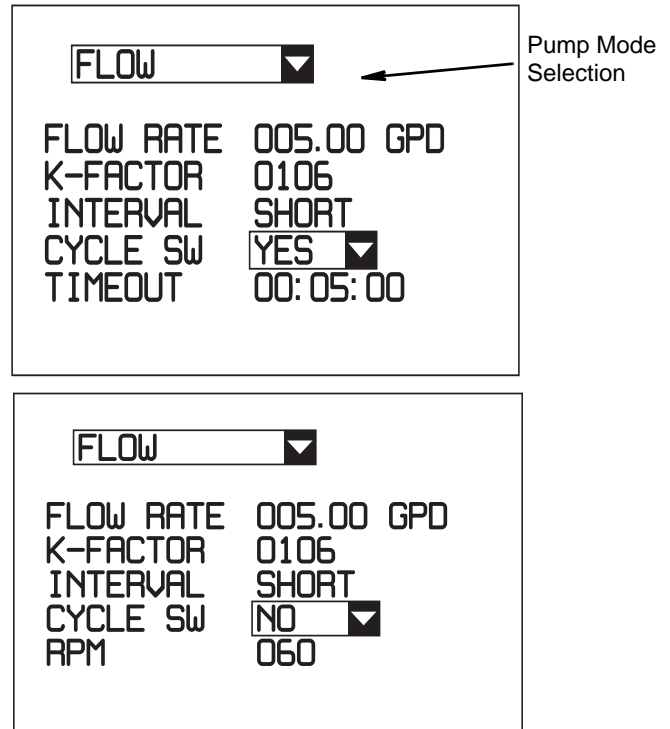


Fig. 20: Pump Setup screen (Flow mode)

The Pump Setup (Flow Mode) screen is used to set the following:

- **FLOW RATE** - The desired number of gallons or liters to be pumped per day (600 GPD/2,271 LPD Max).
- **K-FACTOR** - A coefficient representing the amount of fluid that can be dispensed depending on plunger size.
- **INTERVAL** - The length of the pump's On/Off cycle. Use longer intervals for low flow rates.

- **TIMEOUT** - An alarm is triggered if a cycle is not detected within the time specified in the TIMEOUT field. It resets whenever a cycle is detected. Only available if CYCLE SW = YES.
- **CYCLE SW** - Select NO and enter RPM's if there isn't a reed switch on the pump or select YES and enter timeout if there's a reed switch on pump.
- **RPM** - The RPM rating of the pump, found either on the pump nameplate or by counting and timing actual RPM's. Only available if CYCLE SW = NO.

**NOTE:** Pumps with reed switches will be more accurate than those without

If running a pump without a reed switch, enter the RPM's from the pump nameplate. The totalizer (FLOW MODE only) for CELL or SCADA units will be inaccurate if the RPM value entered is incorrect. For increased accuracy, count the revolutions per minute with a stop watch and enter the number of RPMs counted in one minute.

1. Wait for the pump to be in the off portion of a cycle and display the **Configuration Screen** on page 34.

**NOTE:** If you access the Configuration screen while the pump is running, the accuracy of the calibration will be reduced. If this is a new install, the controller will display the Configuration screen by default.

2. Highlight PUMP and press Enter to display the Pump Setup Screen.
3. Use the Up/Down arrows to move the cursor to the Pump Mode Selection box and press Enter to display the list of mode options.
4. Use the Up/Down arrows to highlight FLOW and press Enter to display the Flow Mode fields.
5. Highlight the FLOW RATE field, and press Enter.
6. Use the arrow keys to highlight and select values for each digit in the desired GPD (gallons per day) or LPD (liters per day) value.
7. Verify the desired value is displayed in the FLOW RATE field, and press Enter.
8. Identify the estimated K-Factor from the table below. You may interpolate between values in the table.

Wolverine/ G-Chem Pumps			
Plunger Diameter	Stroke	K-Factor	
		Simplex	Duplex
3/16 in.	1/4 in.	30	60
	1/2 in.	60	120
	3/4 in.	90	179
	1 in.	120	239
1/4 in.*	1/4 in.	53	106
	1/2 in.*	106	212
	3/4 in.*	159	319
	1 in.*	212	425
3/8 in.*	1/4 in.	120	239
	1/2 in.*	239	478
	3/4 in.*	359	717
	1 in.*	478	956
1/2 in.*	1/4 in.	212	425
	1/2 in.*	425	850
	3/4 in.*	637	1275
	1 in.*	850	1700
5/8 in.	1/4 in.	332	664
	1/2 in.	664	1328
	3/4 in.	996	1992
	1 in.	1328	2656
3/4 in.	1/4 in.	478	956
	1/2 in.	956	1912
	3/4 in.	1434	2869
	1 in.	1912	3825

\*Available on G-Chem Pumps

Wolverine DA Pumps	
Plunger Diameter	K-Factor
3/8 in.	850
1/2 in.	1910
3/4 in.	4307
1 in.	6428

9. Use the arrow keys to highlight and select values for each digit in the K-FACTOR value.

10. Verify the desired value is displayed in the K-FACTOR field, and press Enter.
11. Highlight the INTERVAL field, and press Enter.
12. Highlight the SHORT interval and press Enter. This will set a 1-minute cycle interval to match the calibration column.
13. Highlight CYCLE SW and select YES (See step 14.) if the switch is present or NO if the switch is not present (See step 16.)
14. If the switch is present, highlight the TIMEOUT field, and press Enter.
15. Use the arrow keys to highlight and select values for each digit in the HH:MM:SS format. This timer runs during the pump On cycle, and will reset whenever a cycle is detected. When setting this value, allow enough time for at least one cycle to complete.
16. If switch is not present, enter the RPM value.
17. Verify the desired value is displayed in the TIMEOUT field or RPM, and press Enter.
18. Press Reset to return to the Configuration screen.

### Calibration Column Method

The calibration column method is described in steps 19-25.

19. Fill calibration column and close tank supply. Note the level of the fluid in the calibration column.
20. Note the starting fluid level of the calibration column.
21. Press Reset to resume pump operation.
22. If this is a new install, the pump will begin pumping immediately. Otherwise, press the Left and Right buttons simultaneously to start the pump.
23. Note the finishing fluid level of the calibration column.
24. Calculate the difference between the starting and ending fluid levels. If the calibration column is in units of gallons per hour (GPH) or liters per hour (LPH), convert to GPD or LPD by multiplying by 24.
25. Compare the calibration column value with the desired flow rate.

- a. If the calibration column indicates the system **over-pumped, increase** the K-FACTOR:
  - i - Repeat Step 1.
  - ii - Repeat Step 9, increasing the K-FACTOR field. Press Enter.
  - iii - Repeat Steps 16-22 until the calibration column matches the desired flow rate.
- b. If the calibration column indicates the system **under-pumped, decrease** the K-FACTOR:
  - i - Repeat Step 1.
  - ii - Repeat Step 9, decreasing the K-FACTOR field. Press Enter.
  - iii - Repeat Steps 16-22 until the calibration column matches the desired flow rate.

**NOTE 1:** If the desired flow rate causes the pump to not complete a full revolution of the cam in the short interval set in Step 12, temporarily increase the flow rate in Step 6. After Step 22, you will have the correct K-Factor and can change back to the desired flow rate and change the INTERVAL field to MEDIUM or LONG, verifying the pump completes at least 1 full rotation of the cam when running.

**NOTE 2:** If the desired flow rate is higher than the calibration column can read, temporarily decrease the flow rate in Step 6 to a value the column can read. After Step 22, you will have the correct K-Factor and can change back to the desired flow rate.

**NOTE 3:** You can follow the **Beaker Calibration Method**, see page 45, to replace Steps 19-25.

## Pump Setup Screen (Time Mode)

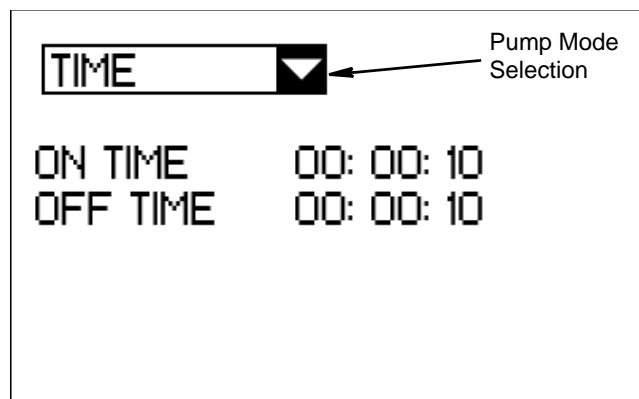


FIG. 21: Pump Setup screen (Time mode)

The Pump Setup (Time Mode) screen is used to set the following:

- **ON TIME** - The desired amount of time the pump is to remain on.
  - **OFF TIME** - The desired amount of time the pump is to remain off.
1. On the **Configuration Screen**, page 34, highlight PUMP and press Enter to display the Pump Setup screen.
  2. Use the Up/Down arrows to move the cursor to the Pump Mode Selection box and press Enter to display the list of mode options.
  3. Use the Up/Down arrows to highlight TIME and press Enter to display the Time Mode fields.
  4. Highlight the ON TIME field, and press Enter.
  5. Use the arrow keys to highlight and select values for each digit in the HH:MM:SS format.
  6. Verify the desired value is displayed in the ON TIME field, and press Enter.
  7. Repeat steps 4-6 for the OFF TIME field.
  8. Press Reset to return to the Configuration screen.

## Pump Setup Screen (Cycle Mode)

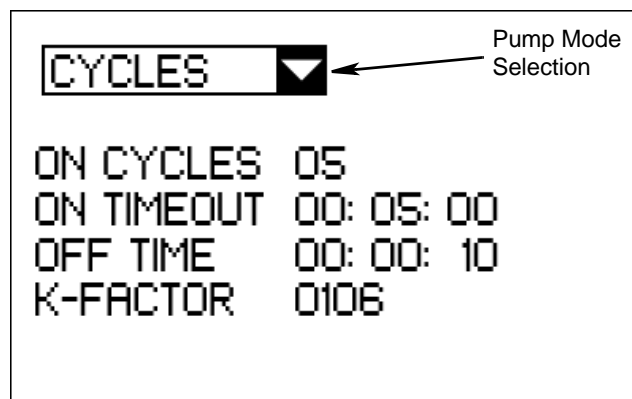


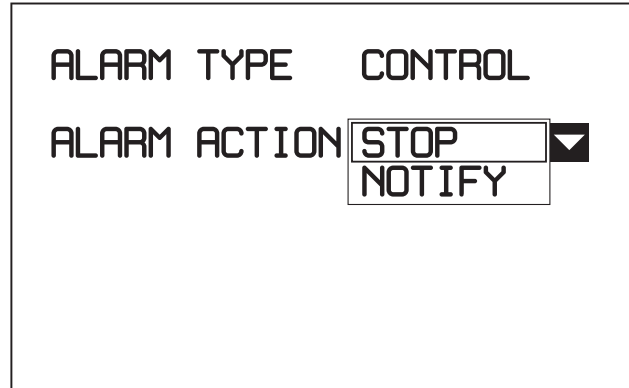
FIG. 22: Pump Setup screen (Cycle mode)

The Pump Setup (Cycle Mode) screen is used to set the following:

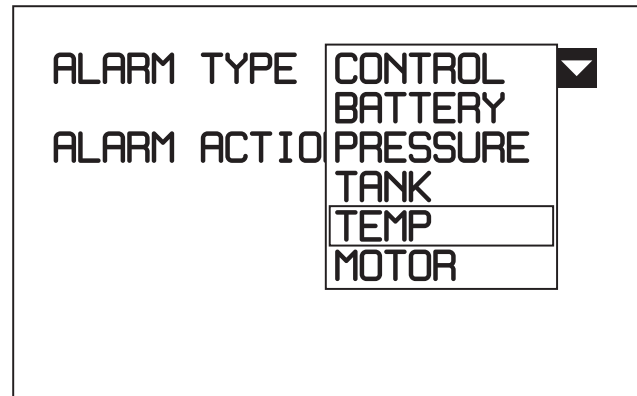
- **ON CYCLES** - The desired number of cycles the pump is to remain on. A cycle is defined as a single rotation of the pump cam, as detected by the cycle switch.
  - **ON TIMEOUT** - An alarm is triggered if a cycle is not detected within the time specified in the ON TIME-OUT field. It resets whenever a cycle is detected. This timer starts when the value in the OFF TIME field expires.
  - **OFF TIME** - The desired amount of time the pump is to remain off after the desired number of cycles in the ON CYCLES field have completed.
  - **K-FACTOR** - See **Pump Setup Screen (Flow Mode)** on page 34.
1. On the **Configuration Screen**, page 34, highlight PUMP and press Enter to display the Pump Setup screen.
  2. Use the Up/Down arrows to move the cursor to the Pump Mode Selection box and press Enter to display the list of mode options.
  3. Highlight CYCLES and press Enter to display the Cycle Mode fields.
  4. Highlight the ON CYCLES field, and press Enter.
  5. Use the arrow keys to highlight and select values for each digit.

6. Verify the desired value is displayed in the ON CYCLES field, and press Enter.
7. Highlight the ON TIMEOUT field, and press Enter.
8. Use the arrow keys to highlight and select values for each digit in the HH:MM:SS format. This timer runs during the pump On cycle, and will reset whenever a cycle is detected. When setting this value, allow enough time for at least one cycle to complete.
9. Verify the desired value is displayed in the ON TIMEOUT field, and press Enter.
10. Repeat steps 7-9 for OFF TIME field.
11. Highlight the K-FACTOR field, and press Enter.
12. Use the arrow keys to highlight and select values for each digit in the desired K-Factor.
13. Verify the desired value is displayed in the K-FACTOR field, and press Enter.
14. Press Reset to return to the Configuration screen.

## Alarms Setup Screen



**FIG. 23: Alarm Setup Screen, Alarm Action items**



**FIG. 24: Alarm Setup Screen, Alarm Type Items**

- **ALARM TYPE** - Highlight alarm type and press Enter to display related alarms.
  - CONTROL- See **Control Alarms**, page 39.
  - BATTERY - See **Battery Alarms**, page 39.
  - PRESSURE - See **Pressure Alarms**, page 40.
  - TANK - See **Tank Alarms**, page 40.
  - TEMP - See **Temperature Control Alarms**, page 41.
  - MOTOR - See **Motor Over Current Alarm**, page 42.

- **ALARM ACTION** - Specify the action to be taken when an alarm is triggered.
  - STOP - Stop the pump.
  - NOTIFY - Alarm is triggered, but pump continues running.

The table below shows which alarms the alarm action applies to and which ones are notify, alarm only, or signal events.

Alarm Actions			
Alarm Name	Stop	Notify	Signal Event
Input 1	✓	✓	
Input 2	✓		
Remote Input			✓
High Pressure	✓	✓	
Low Pressure	✓	✓	
Counts Not Achieved	✓	(Flow Mode Only)	
Low Battery	✓		
Analog In		✓	
Temperature			✓
Over Current	✓		
Power Save Mode			✓
Modbus Comms		✓	

### Control Alarms

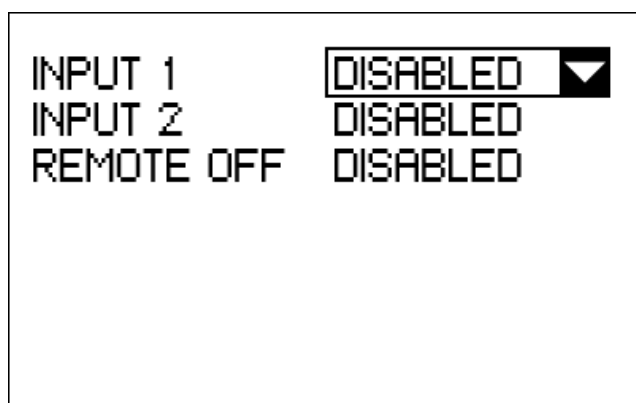


FIG. 25: Control alarms

- **INPUT 1** - Enable or disable a generic input alarm. When enabled, the alarm can be set for either normally closed or normally open switches. See **Alarms and Signal Events**, page 51.

- **INPUT 2** - Enable or disable a generic input alarm. When enabled, the alarm can be set for either normally closed or normally open switches. See **Alarms and Signal Events**, page 51.
- **REMOTE OFF** - Enable or disable a remote input event. When enabled, the alarm can be set for either normally closed or normally open switches. See **Alarms and Signal Events**, page 51.

### Normally Open/Normally Closed Settings

#### Normally Open:

- For INPUT 1 & 2, triggers alarm when signal is high (switch open).
- For REMOTE OFF, puts pump into standby when signal is high (switch open).

#### Normally Closed:

- For INPUT 1 & 2, triggers alarm when signal is low (switch closed).
- For REMOTE OFF, puts pump into standby when signal is low (switch closed).

### Battery Alarms

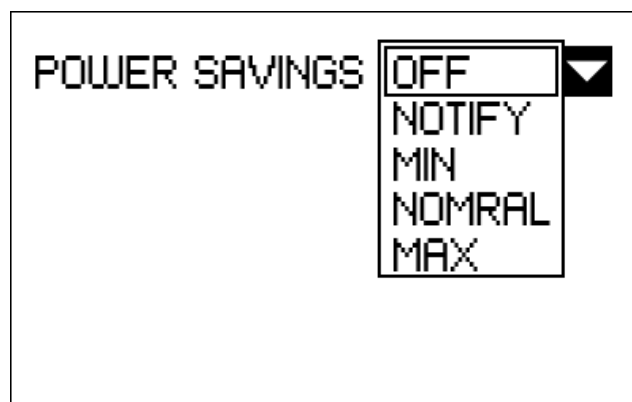
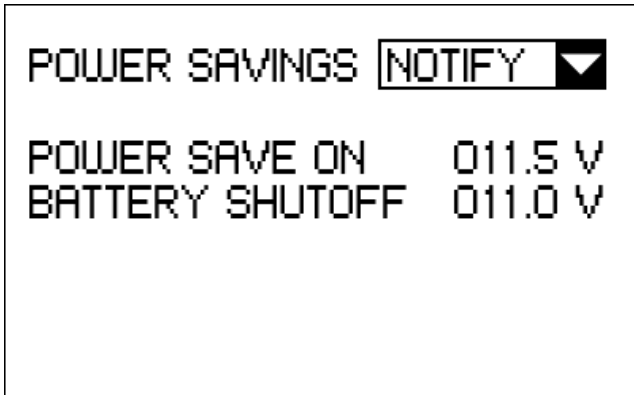


FIG. 26: Power savings selections

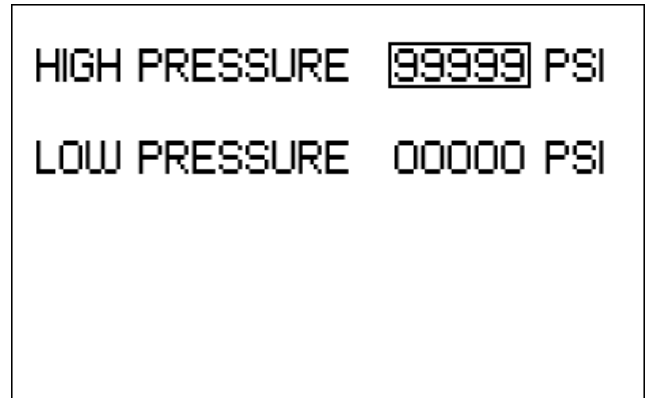
- **POWER SAVINGS** - Specifies the action taken by the controller when the pump enters Power Save mode. This is an optional feature that requires a battery monitor. (See **Typical 12 or 24 VDC Installation and Wiring**, page 10.) Actions include:
  - OFF - Turn Power Save mode Off.
  - NOTIFY - Warns user of low battery, but does not reduce pump On time.
  - MIN - Reduces pump On time to 75%.  
Ex: If On Time = 60 seconds, the pump will only run for 45 seconds.
  - NORMAL - Reduces pump On time to 50%.  
Ex: If On Time = 60 seconds, the pump will only run for 30 seconds.
  - MAX - Reduces pump On time to 25%.  
Ex: If On Time = 60 seconds, the pump will only run for 15 seconds.



**FIG. 27: Battery alarms**

- **POWER SAVE ON** -The controller enters Power Save mode when battery voltage drops below the value specified. This field is not displayed when Power Save mode is Off. Setting a value here enables power save mode and the controller will perform the action specified in the power savings select box.
- **BATTERY SHUTOFF** - An alarm is activated when the battery voltage drops below the value specified. This field is not displayed when Power Save mode is Off.

## Pressure Alarms



**FIG. 28: Pressure alarms**

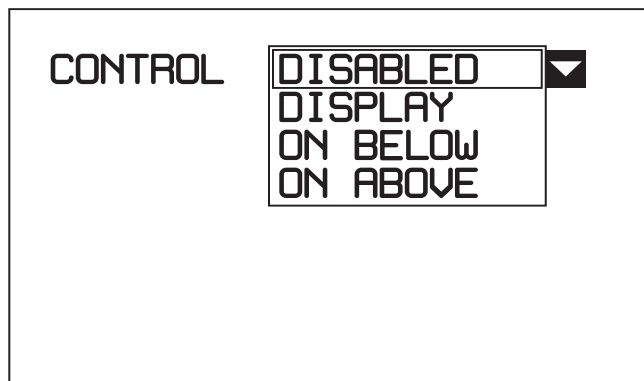
- **HIGH PRESSURE** - An alarm is activated when the pressure is higher than the value specified.
- **LOW PRESSURE** - An alarm is activated when the pressure is lower than the value specified.

## Tank Alarms

This is an optional feature that requires a tank level monitor. See Tank Level Monitoring Kit manual (3A5375).

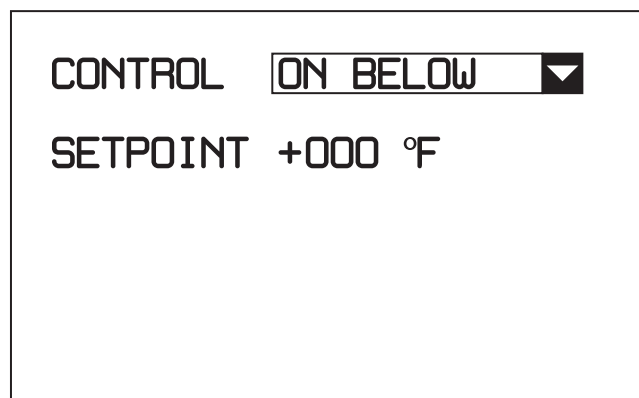


## Temperature Control Alarms

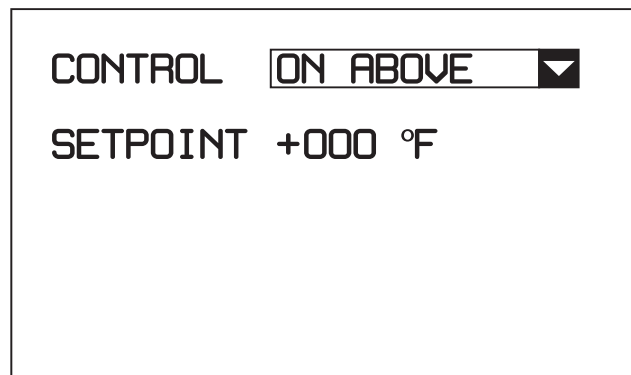


**FIG. 29: Temperature Control Setup Screen**

- **CONTROL** - Highlight type and press ENTER to display related alarms.
  - **DISABLED** - Disables reading and displaying temperature
  - **DISPLAY** - Display temperature on the run screen only, no pump control.
  - **ON BELOW** - Turn pump on below setpoint and display temp on run screen.
  - **ON ABOVE** - Turn pump on above setpoint and display temp on run screen
  - **SETPOINT** - The temperature at which the pump turns on at (-40°F to 118°F). Selecting ON ABOVE or ON BELOW enables temp control and will prompt user to enter the SETPOINT.



**FIG. 30: ON BELOW**



**FIG. 31: ON ABOVE**

Temp control allows the controller to read an external temperature probe to monitor the temperature and turn a pump on below or above a given temperature (See Fig. 16). ON BELOW is commonly used to turn a pump on below a certain temperature for cold weather applications.

DISPLAY only mode will not turn a pump on but will display the temperature on the controller. It'll also display and graph it in the historical charts on the web portal for CELL devices.

Graco offers a lug style temperature sensor (kit B32989) and a probe style temperature sensor (kit B32131). The user may also supply their own sensor but it must match the specs below to maintain accuracy.

- **Thermistor Type** = NTC
- **Resistance @ 25°C** = 10,000  $\Omega$
- **R-T Curve** = J
- **Beta (0-50°C)** = 3892K
- **Resistance Tol.** -20°C to 20°C =  $\pm 1\%$
- **Temp. Coefficient @ 25°C** = -4.4 %/°C
- **Temperature Range** = -55°C to 105°C

## Motor Over Current Alarm

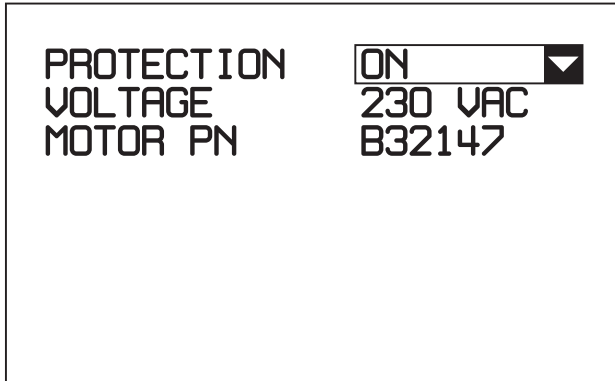


Fig. 32: PROTECTION ON Screen

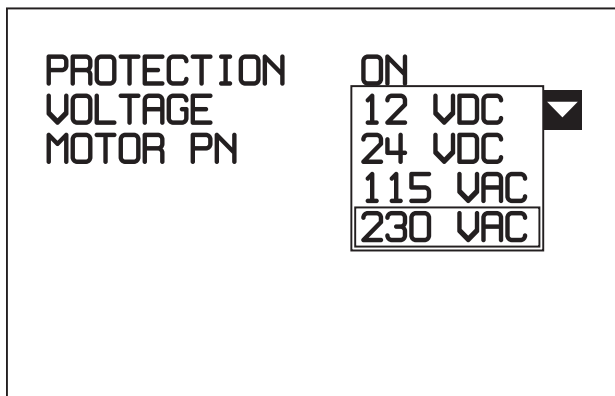


Fig. 33: VOLTAGE Screen

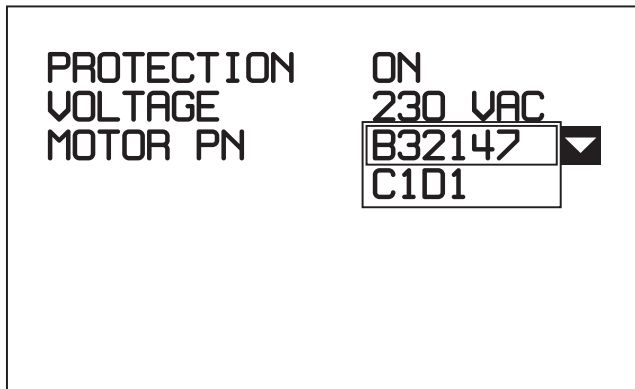


Fig. 34: MOTOR PN Screen

The Harrier+ controller continuously monitors the amperage load of the motor. The controller will stop the pump and enter an alarm state if the amperage rises above the motor's or controller's rated max limit, depending on the settings selected.

- PROTECTION - ON prompts for inputs on the system voltage and motor PN & will set the amperage limit according to the motor PN. OFF opens the amperage limit to the controller's rated max limit.
- VOLTAGE - The system and motor voltage.
- MOTOR PN - The specific motor PN or type of motor, ie: C1D1, used in the system.

When PROTECTION is ON, an alarm is activated when the amperage detected by the controller rises above the *motor's* rated amperage, for an extended period of time

When PROTECTION is OFF, an alarm is activated when the amperage detected by the controller rises above the *controller's* rated amperage, for an extended period of time.

## PIN Code Setup Screen

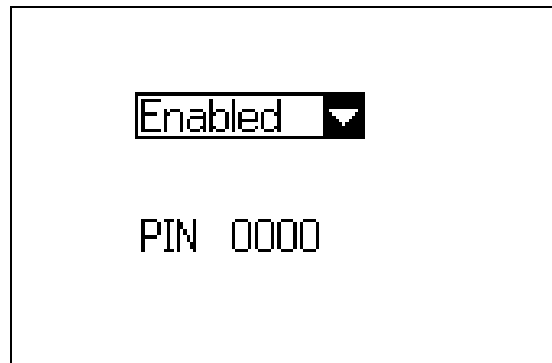


Fig. 35: PIN Code Setup screen

The PIN Code Setup screen allows you to enable a PIN Code (see FIG. 36) that prevents access to the Configuration screen (see FIG. 19) without the correct PIN Code.

1. On the **Configuration Screen**, page 34, highlight PIN CODE and press Enter to display the PIN Code setup screen.
2. Use the arrow keys to highlight the selection box, and press Enter.
3. Use the arrows to highlight either Enabled or Disabled, and press Enter.
4. If you selected Enabled, a pin box pops up. Use the arrow keys to highlight and select the desired value for the each digit in the PIN field. See FIG. 36.

**NOTE:** If you do not have the correct PIN code, you will not be able to regain access to the Configuration screen. Record your PIN Code before enabling PIN Code Entry. Contact Graco Customer Support if PIN is forgotten.

5. Verify the desired code is displayed in the PIN field, and press Enter.
6. Press Reset to return to the Configuration screen.

## PIN Code Entry Screen



**Fig. 36: PIN Code Entry screen**

The PIN Code Entry screen appears before the Configuration screen only if PIN Code Entry was enabled on the PIN Code Setup screen (see 35).

1. Hold down the Enter key for 3 seconds to display the PIN Code Entry screen.
2. Use the arrows to highlight and select a value for each digit in the PIN code.
3. Verify the desired PIN code is displayed, and press Enter.
  - If the PIN code you entered is correct, the Configuration screen is displayed.
  - If the PIN code you entered is incorrect, the PIN Code Entry screen remains displayed. The Code must be re-entered by repeating step 2.

## Network Setup Screen

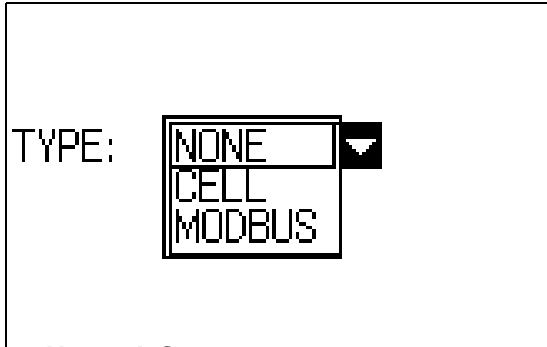


FIG. 37: Network Setup screen

The Network Setup screen is used to set the following:

- **CELL** - Allows controller to communicate to Harrier+ web portal. Only for controllers with cell modems. See **Models** on page 3.
  - **MODBUS** - Enables Modbus communication between the controller and a Supervisory Control and Data Acquisition (SCADA) system to remotely monitor and control your pump. (See **Typical Installations**, starting on page 10.) Only for SCADA systems without a cell modem. See **Models** on page 3.
1. On the Configuration screen (see FIG. 19), select NETWORK from the list of setup screens, and press Enter to display the Network Setup screen (see FIG. 37).
  2. Use the arrows to highlight the TYPE field, and press Enter.
  3. Use the Up/Down arrows to highlight the desired network connection, and press Enter.
  4. Turn the Harrier+ controller Off and On after changing TYPE.

## Cell Network Setup

1. From the Network Setup screen, select CELL in the TYPE field and press Enter to display the Activation Code screen.

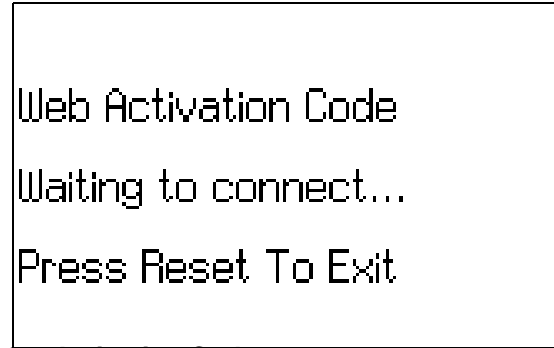


FIG. 38: Activation Code screen

If you press the Reset key while waiting to connect and return to the Network Setup screen, You will see the following screen.

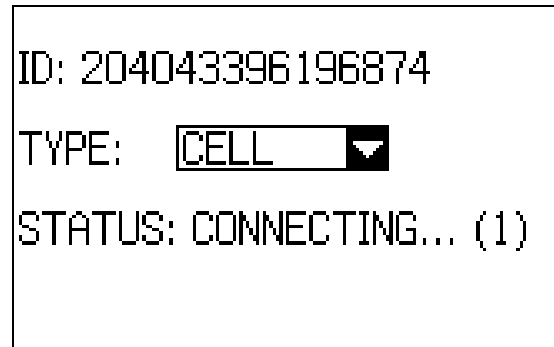


FIG. 39: Cell network connecting

Once connected, the network screen will display the pump name, pump ID, and signal strength.

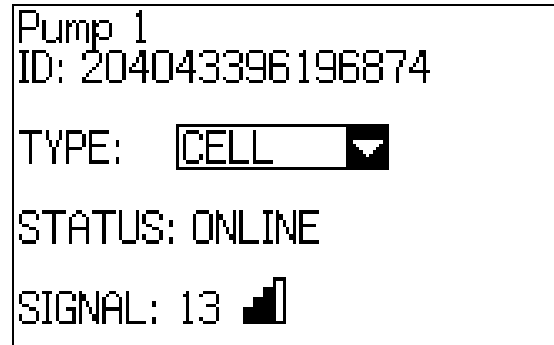


FIG. 40: Cell network connected

It is optimal to have more than one bar of signal strength. If you do not, you may move the equipment for better reception, or refer to **Troubleshooting** on page 70.

2. With CELL selected and STATUS: ONLINE, press the Enter key to display the Web Activation Code. This code is required for remote access to the pump when **Creating a New Account** on page 54.

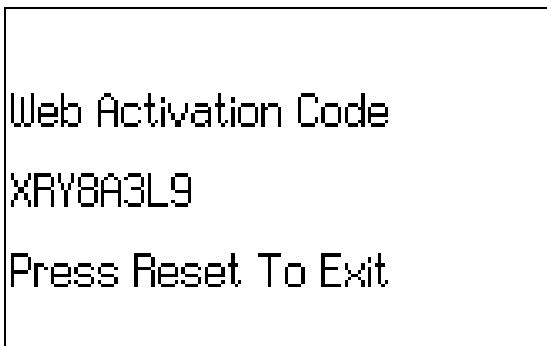


Fig. 41: Cell network Web Activation Code

3. Press Reset to return to the Network Setup screen.

### Modbus Network Setup

With MODBUS selected, fields for a SLAVE ID, baud rate, parity, and stop bits will appear. See **Appendix A: Modbus Interface**, page 76, for details on interfacing with the controller. These settings must match the SCADA system or PC modbus master.

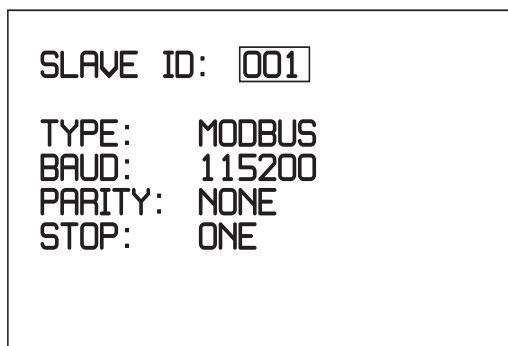


Fig. 42: Network Setup screen

- **SLAVE ID** - The slave ID identifies the Harrier+ controller within the SCADA system, Each controller in the SCADA system must have a unique slave ID between 1 and 247.
- **TYPE** - Select MODBUS for SCADA units. The controller uses MODBUS RTU/RS232 to communicate with a SCADA system. Converters or gateways can be connected to support other protocols.

- **BAUD** - Selectable baud rate serial port settings, options include 9,600 bits/sec, 19,200 bits/sec, 57,600 bits/sec, and 115,200 bits/sec.
- **PARITY** - Selectable serial port settings for parity, options include None, Odd, or Even.
- **STOP** - Selectable serial port settings for number of stop bits, options include One or Two.

1. Highlight the SLAVE ID field, and press Enter.
2. Use the arrow keys to highlight and select a value for each digit of the slave ID, and press Enter.
3. Use the arrow keys to navigate to each of the following fields: BAUD, PARITY, and STOP.
4. Press Enter to display each field option and use the arrow keys to highlight the option then press Enter to select.
5. Press Reset to return to the Configuration screen.

### Advanced Setup Screen

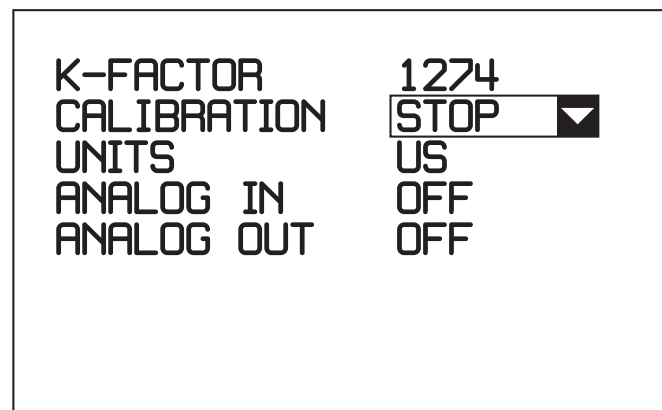


Fig. 43: Advanced Setup screen

The Advanced Setup screen is used to set the following:


- **K-FACTOR** - The current K-Factor. It cannot be edited on this screen, though it is automatically updated during calibration.
- **CAL VOLUME** - The volume pumped during calibration. Only appears during calibration.
- **CALIBRATION** - Calibrates the pump by automatically setting the K-Factor according to the volume dispensed. This will override any previous K-Factor entries on other setup screens. Calibration of the K-Factor is optional, though it does affect the accuracy of the actual flow rate and totalizers. Press start to initiate calibration.

Calibration can be stopped in one of two ways:

- Selecting STOP in this field.
  - Completing 5 cycles.
- **UNITS** - Specifies whether units are displayed as US or metric.
  - **ANALOG IN** - Allows an external 4-20 mA signal to vary the flow. (Flow Mode only) (See Analog In Screen).
  - **ANALOG OUT** - Enables the controller to output a 0-5V signal to control a variable speed motor (Flow Mode Only) (See Analog Out Screen).
1. On the Configuration screen, select ADVANCED from the list of setup screens, and press Enter to display the Advanced Setup screen.

### Beaker Calibration Method

The beaker calibration method is described in steps 2-6.



This device automatically dispenses fluid once START is selected in the CALIBRATION field. To reduce the risk of serious injury, including skin injection, ensure that hands are clear of the outlet line and that a calibration beaker is in place before starting calibration.

2. Only if pump calibration is needed using beaker method, direct an outlet line to the calibration beaker before starting calibration (Refer to the Wolverine pump manual (334513) for the location of the outlet line and for the appropriate Pressure Relief Procedure).
3. Highlight CALIBRATION, and press Enter.
4. Highlight START and press Enter to immediately begin dispensing fluid into beaker.

**NOTE:** Calibration can be stopped in one of two ways:

- Selecting STOP in this field.
  - Completing 5 cycles, as detected by the reed switch.
5. Measure the fluid volume dispensed into the beaker and enter it in the CAL VOLUME field of the

Advanced Setup Screen, which only appears after the calibration cycles are completed.

6. The K-Factor field is automatically updated with the new K-FACOTR that reflects the volume dispensed.
7. Highlight Analog In and press Enter on OFF or ON to pop up the Analog In setup screen (See Analog In).
8. Highlight Analog Out and press Enter on FLOW to pop up the Analog Out setup screen (See Analog Out).
9. Press Reset to return to the Configuration screen.

### Analog In

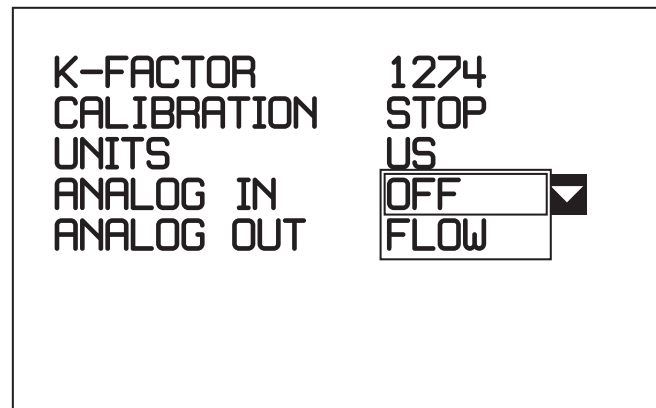


FIG. 44: ANALOG IN

Set ANALOG IN to FLOW to enable analog in and display the setup screen below.

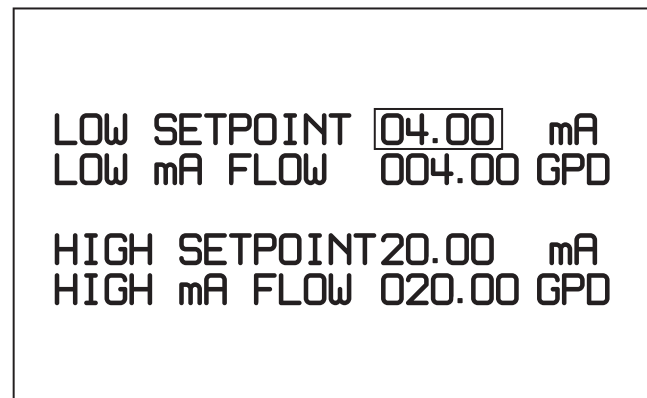


FIG. 45: ANALOG IN Setpoint Setup Screen

If analog in is enabled, a 4-20mA analog input signal can be used to automatically vary the flow rate (See FIG. 8 - FIG. 10). A common example is to use it to automatically adjust the flow rate based on a gas meter.

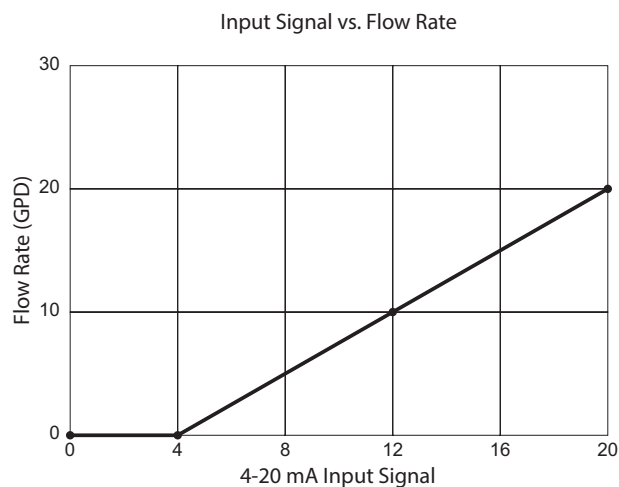
The flow rate is automatically calculated based on the 4-20mA input. It is scaled linearly between the high and low setpoints entered on this screen.

The Analog In Screen is used to set the following:

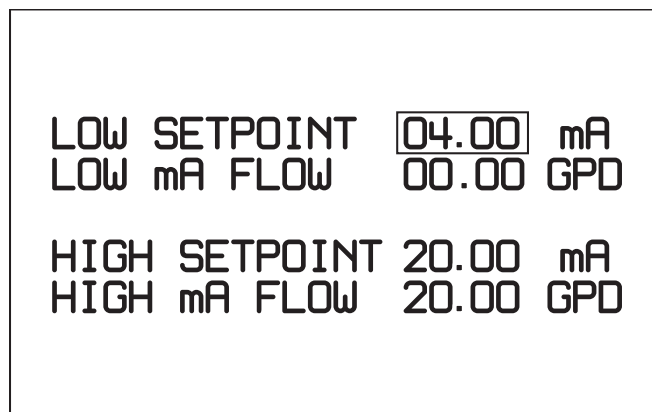
- **Low Setpoint** - The lowest mA value used on the 4-20mA range.
- **Low mA Flow** - The flow rate that corresponds to the low mA value. At "Low mA", the flow rate will be "Low mA Flow".
- **High Setpoint** - The highest mA value used on the 4-20mA range.
- **High mA Flow** - The flow rate that corresponds to the high mA value. At "High mA", the flow rate will be "High Flow Rate".

The flow rate cannot be adjusted manually when analog in is enabled, and therefore, is removed from the Pump Setup Screen and becomes read only on the web portal for CELL units.

**Example 1: Full Range Setup**



**Fig. 46: Full Range Setup**



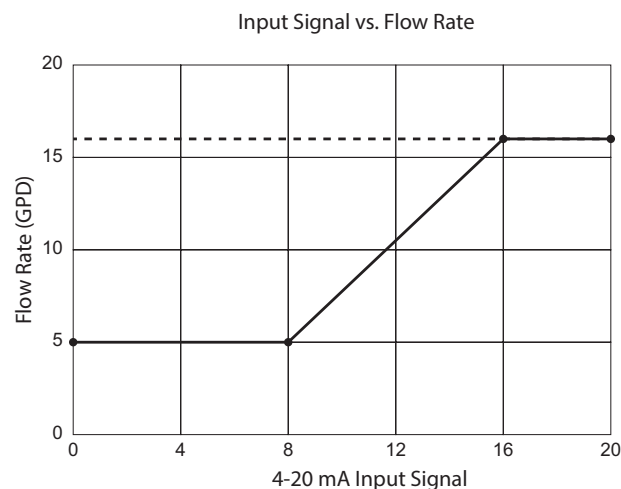
**Fig. 47: Full Range Setup**

1. Set inputs on Analog In Screen as shown.
2. Flow Rate is scaled linearly between 4 to 20mA and 0 to 20 GPD.

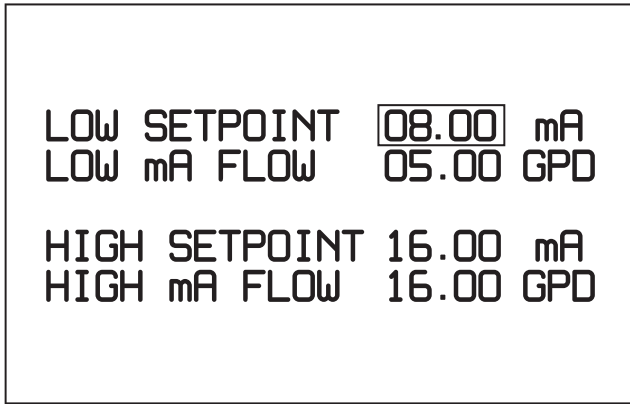
3. Signals less than 4mA are clamped to 0 GPD

4 mA = 0 GPD  
 12 mA = 10 GPD  
 20 mA = 20 GPD

**Example 2: Subset of Full Range Setup**



**Fig. 48: Subset of Full Range Setup**

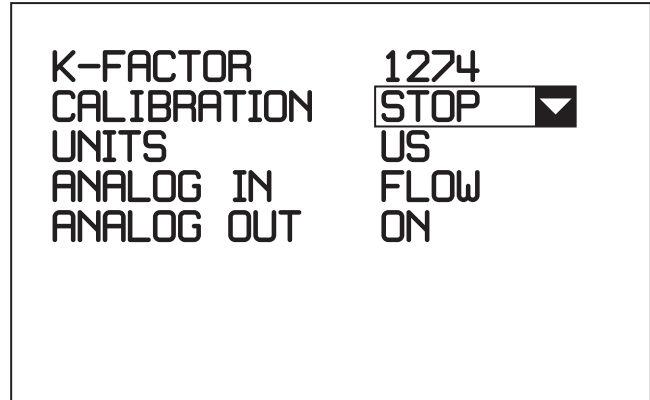


**FIG. 49: Subset of Full Range Setup**

1. Set inputs on Analog In Screen as shown.
2. Flow rate is scaled linearly between 8 to 16 mA and 5 to 16 GPD.
3. Signals less than 8 mA are clamped to the low flow rate, 5 GPD. Anything less than 8mA will set the flow rate to 5 GPD.
4. Signals greater than 16 mA are clamped to the high flow rate. Anything greater than 16mA will set the flow rate to 16 GPD.

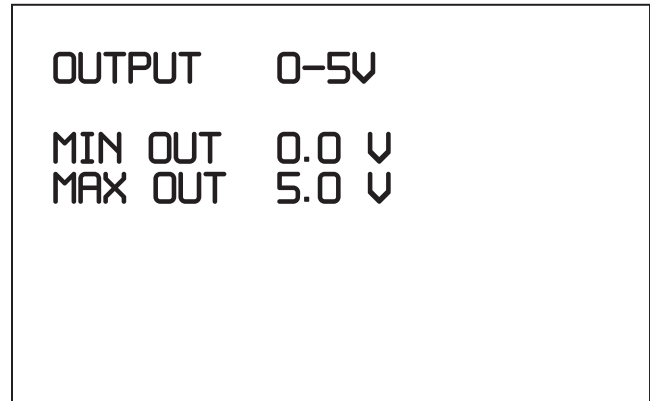
The analog input can also be used in combination with the analog output to control a variable speed pump as the input signal changes. As the flow rate is automatically adjusted based on the input signal, the controller will automatically adjust the speed control voltage signal accordingly.

## Analog Out



**FIG. 50: Analog Out Screen**

Set ANALOG OUT to ON to enable analog out and display the setup screen below.



**FIG. 51: Analog Output**

If analog out is enabled, a 0-5V analog output signal can be used to control a variable speed motor (See FIG. 12). A theoretical maximum flow-rate is calculated using the k-factor. The 0-5V analog output signal supplied to the motor is then scaled linearly between zero and the calculated maximum flow rate.

The Analog Out Screen is used to set the following:

- MIN OUT - The lowest voltage the controller will output and therefore, corresponds to the minimum speed the pump will run at.
- MAX OUT - The highest voltage the controller will output and therefore, corresponds to the maximum speed the pump will run at.

The analog output is scaled in one of two ways:



1. The voltage output is a fixed value based on a percentage of the desired flow rate entered on the pump screen vs. the max flow rate of the pump.
2. The voltage output varies automatically based on the analog input. It's scaled based on a percentage of the analog flow rate calculated based on the analog input vs the max flow rate of the pump. It follows the analog input. As the input increases or decreases, so does the output.

ie:

MIN OUT = 0V

MAX OUT = 5V

Desired or Analog Flow Rate = 5 GPD

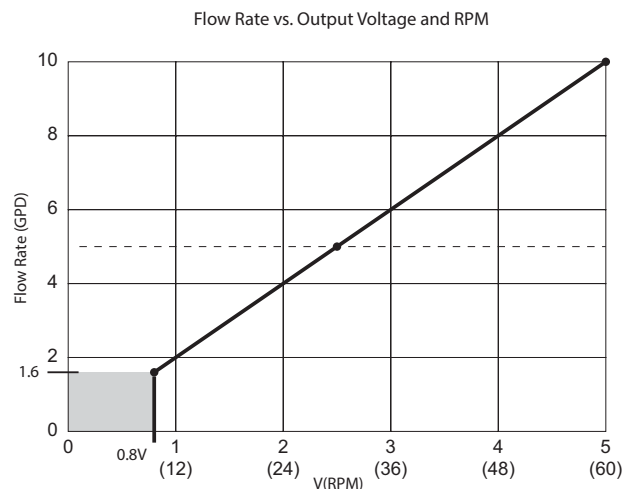
Max Flow Rate = 10 GPD

Analog Out = 2.5V

The max flow rate is a theoretical max based on the K-Factor.

The pump will stall at approximately 10 RPM = 0.8V on a 5V variable speed motor. This corresponds to a minimum GPD that can be pumped before the pump stalls. To prevent stalling, care must be taken to make sure the desired flow rate or the analog input signal aren't so low that they are trying to drive an output voltage less than 0.8V.

The variable speed pump runs continuously and adjusts the speed up or down to hit a desired flow rate. Running at 5V will run the pump at max speed. Running less than 0.8V will stall the pump and 0V will stop the pump.



**Fig. 52: Minimum Voltage at Which the Pump Stalls is 0.8V or 10 RPM**

MIN OUT = 0V = 0 RPM

MAX OUT = 5V = 60 RPM Nominal

Stall Deadband = 0V-0.8V

In this example, See FIG. 52, the minimum flow rate the pump can do before stalling is 1.6 GPD. The max flow rate is 10 GPD at 5V. At 2.5 V the flow rate is 5 GPD.

### Variable Speed Calibration

The pump must run at full speed while calibrating a variable speed pump. The controller will supply MAX OUT voltage to the motor while analog out is turned off to ensure full speed operation. Complete the steps below to set the pump to full speed & calibrate a variable speed pump.

1. Hit ENTER on the ANALOG OUT select box to bring up the analog out screen.
2. Set the Max Volts to 5V (Full Speed).
3. Exit back to the Advanced Screen by pushing the reset button.
4. Make sure ANALOG OUT says OFF.
5. Follow the calibration column or beaker method to calibrate your pump.
6. Set ANALOG OUT to ON once calibration is complete.

- Set the desired flow-rate using FLOW mode to set a fixed output or enable ANALOG INPUT to have the output follow an input signal.

## Fluid Pressure Setup Screen

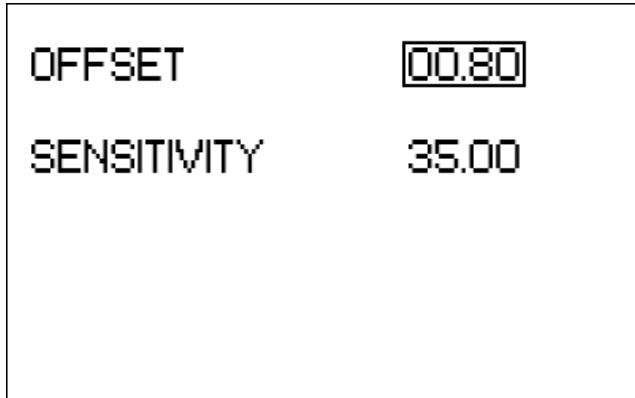


FIG. 53: Advanced Setup screen

The Fluid Pressure screen is used to set the following:

- OFFSET**- The calibration offset value from the pressure transducer label. This is an optional feature that requires a pressure transducer. (See **Typical Installations** starting on page 10.)
- SENSITIVITY** - The calibration sensitivity value from the pressure transducer label. This is an optional feature that requires a pressure transducer. (See **Typical Installations** starting on page 10.)

- If pressure transducer calibration is desired, high-light PRESS OFFSET and press Enter.
- Use the arrows to highlight and select a value for each digit of the pressure offset.
- Verify the desired value is displayed in the PRESS OFFSET field, and press Enter.
- If pressure transducer calibration is desired, high-light PRESS SENSITIVITY and press Enter.
- Use the arrows to highlight and select a value for each digit of the pressure sensitivity.
- Verify the desired value is displayed in the PRESS SENSITIVITY field, and press Enter.

## Tank Level Setup Screen

This is an optional feature that requires a tank level monitor. See Tank Level Monitoring Kit manual (3A5375).

## Run Screens

### Screen Identification

The following screen is only shown as an example of the information that is displayed on a Run screen. A complete description of the icons and symbols shown in FIG. 54 is provided on page 7.

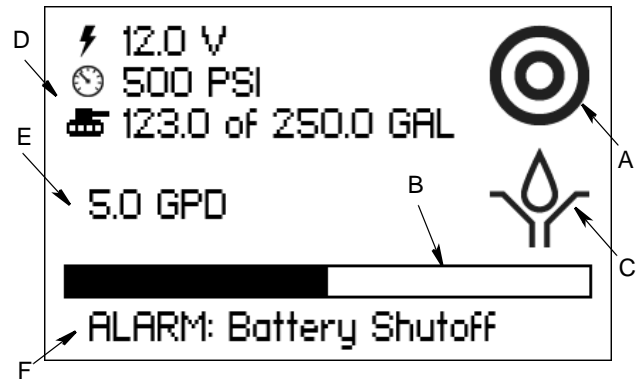


FIG. 54: Run Screen

- A Operating Mode Identification** - Displays Flow Mode Active, Time Mode Active, or Cycle Mode Active icons depending on which metering mode is selected.
- B Progress Bar** - Real-time, visual representation of the elapsed time during a Pump On or Pump Off cycle.
- C Pump On/Off Indicator** - Visual indication of whether the pump is completing an On Cycle or Off Cycle.
- D DC Voltage, Pressure, Temperature and Tank Level** - Real-time voltage and pressure values. DC Voltage is not displayed when Power Save mode is Off. Pressure appears for both AC and DC models. Displays 0 PSI when no pressure transducer is connected. Real-time tank level and temperature.
- E Pump Run Summary** -
  - Flow Mode - Displays current desired Flow Rate
  - Time Mode - Displays current desired On and Off Times
  - Cycle Mode - Displays current desired On Cycle and Off Time
- F Status Line** - Area where status messages are displayed.

## Alarms and Signal Events

When an alarm or signal event occurs, the Run screen displays a status message indicating an alarm or event is active (see F on FIG. 54) and the Function LED (see FIG. 1) is lit. When an alarm or event is active, the pump goes into Standby mode.

To clear an alarm,

- Press the Reset key on the controller (see **Keypad, Display, and Icons**, page 6).
- Press the Reset icon on the Web application (see **Pumps Detail Screen (Pump Connected)**, page 59). Available on CDMA and GSM models. (See **Models**, page 3.)
- Send a Reset command through the SCADA interface using the Modbus map (see **Appendix A: Modbus Interface**, page 76). Available on SCADA models. (See **Models**, page 3.)





The following is a list of alarm events that may display.

**Table 1: Alarm Events**

Name	Type	Trigger Condition	Fixes and Actions
Input 1 Ex. Tank Switch	Alarm	Switch activated according to the Normally Open / Normally Closed setting on the <b>Alarms Setup Screen</b> , page 38.  Ex: Tank level is low	Check the device being monitored and reset the alarm.  Ex: Refill the tank and press Reset on the controller.
Input 2	Alarm	Switch activated according to the Normally Open / Normally Closed setting on the <b>Alarms Setup Screen</b> , page 38.	Check the device being monitored and reset the alarm.
Disabled by Remote Ex. Temperature Switch	Signal Event	The remote input sets the pump to Standby mode automatically according to the Normally Open / Normally Closed settings on the <b>Alarms Setup Screen</b> , page 38. Ex: Temperature is high	None required. The signal event automatically clears and sets the pump to Run mode without input from the user. Ex: Temperature falls enough to trip temperature switch and start pump.
High Pressure	Alarm	Pressure above the threshold set by user on the <b>Alarms Setup Screen</b> , page 38.	Check the system pressure and reset the alarm.
Low Pressure	Alarm	Pressure below the threshold set by user on the <b>Alarms Setup Screen</b> , page 38.	Check the system pressure and reset the alarm.
Counts Not Achieved	Alarm	Cycle switch signal not detected within the value specified in the Timeout fields of the <b>Pump Setup Screen (Flow Mode)</b> , page 34, and the <b>Pump Setup Screen (Cycle Mode)</b> , page 37.	Check wiring. Replace the cycle switch and reset the alarm.

Name	Type	Trigger Condition	Fixes and Actions
Low Battery	Alarm	Battery voltage is below the value specified in the Battery Shutoff field of the <b>Alarms Setup Screen</b> , page 38.	Check solar panel connection. Replace battery. Alarm clears automatically when voltage is > threshold + 0.5V, or when the alarm is reset.
Analog In	Notification	The 4-20mA analog input is out of range, greater than 21mA or less than 3mA.	Measure the analog input & make sure it's within the 4-20mA range. Check wiring. Automatically clears when the signal rises above 4mA or below 20mA.
Temperature	Signal Event	Sets the pump to Standby mode automatically when the temperature rises above or below the set-points defined on the Alarms Setup Screen.	None required. The signal event automatically clears and sets the pump to Run mode without input from the user when the temperature changes. On Below: clears when temp is 2 degrees less than setpoint. On Above: clears when temp is 2 degrees more than setpoint. Check wiring if temperature is stuck at the max 118° F.
Over Current	Alarm	Motor amperage rises above the pump or controller rated maximum output capacity for an extended period of time.	Measure current draw of motor with current clamp & look for causes of overload condition like a closed ball valve. Reset the alarm.
Power Save Mode	Signal Event	Controller decreases the pump's on time by a MIN, NORMAL, & MAX percentage when the battery voltage drops below the POWER SAVE ON threshold (See the Alarms Setup Screens).	Check the battery voltage and charge batteries. Pump will run for less time to save battery voltage until condition is fixed or battery shutoff is reached.
Modbus Comms	Notification	Notifies user that modbus communication on SCADA units has been lost if the modbus comms alarm is enabled via SCADA.	Check the SCADA link to the controller, any converters, and wiring to re-establish communication.

# Harrier+ Web Portal

				
<b>AUTOMATIC SYSTEM ACTIVATION HAZARD</b>				
<p>Unexpected activation of the system could result in serious injury, including skin injection and amputation.</p>				
<p>This device has an automatic timer that activates the chemical injection system when power is connected or when exiting the programming function. The device can also be activated remotely from internet portals. Before you install or remove the controller from the system, disconnect and isolate all power supplies, and relieve all pressure.</p>				

The Harrier+ Web Portal allows you to remotely monitor and control your chemical injection pump from any computer or device with Internet access.

**NOTE:** Web Portal screens may be subject to continuing updates. See [harrier.graco.com](http://harrier.graco.com) for updates and the most recent information.

## Creating a New Account

1. Go to <https://harrier.graco.com> to display the Graco login screen and select **Register new account** to display the Register New Account screen.



### Register » New account

All fields are required.

EMAIL	<input type="text" value="Email"/>
FIRST NAME	<input type="text" value="First name"/>
LAST NAME	<input type="text" value="Last name"/>
PASSWORD	<input type="text" value="New password"/>

The pump activation key is displayed on the pump controller's network configuration screen. Choose "cell" from the drop-down menu on the controller to display the key.

PUMP ACTIVATION KEY	<input type="text" value="Pump activation key"/>
---------------------	--

Choose a name for your group below. This will create a new group. Good choices could include your company or your division. If you want to join an existing group, have the group manager send you an invitation from the group's page.

GROUP	<input type="text" value="Group"/>
-------	------------------------------------

Register

FIG. 55: Register New Account screen

2. Fill in the fields on the Register New Account screen, following the on-screen instructions, and click **Register** to display the Account Pending screen. Call Graco Customer Support if you need assistance.



---

## Account pending

Thank you for registering!

We've sent you an account activation message to the email address you provided. To finish activating your account, follow the link in that email.

If you don't receive an email from us within the next hour, please be sure to check your spam or junk folder.

Pump Control v1.0.281

---

**FIG. 56: Account Pending screen**

3. Check your email for an account activation message from Graco. Follow the instructions to activate your account and to display the Activation Complete screen.



---

## Activation complete

Thank you for verifying your email address. Your account is now active.

You may log in now using your email address and the password you specified when setting up your account.

If did not set a password for your account, you can do so by using the [Forgot Password](#) link on the login page.

[Return to login page](#)

Pump Control v1.0.290

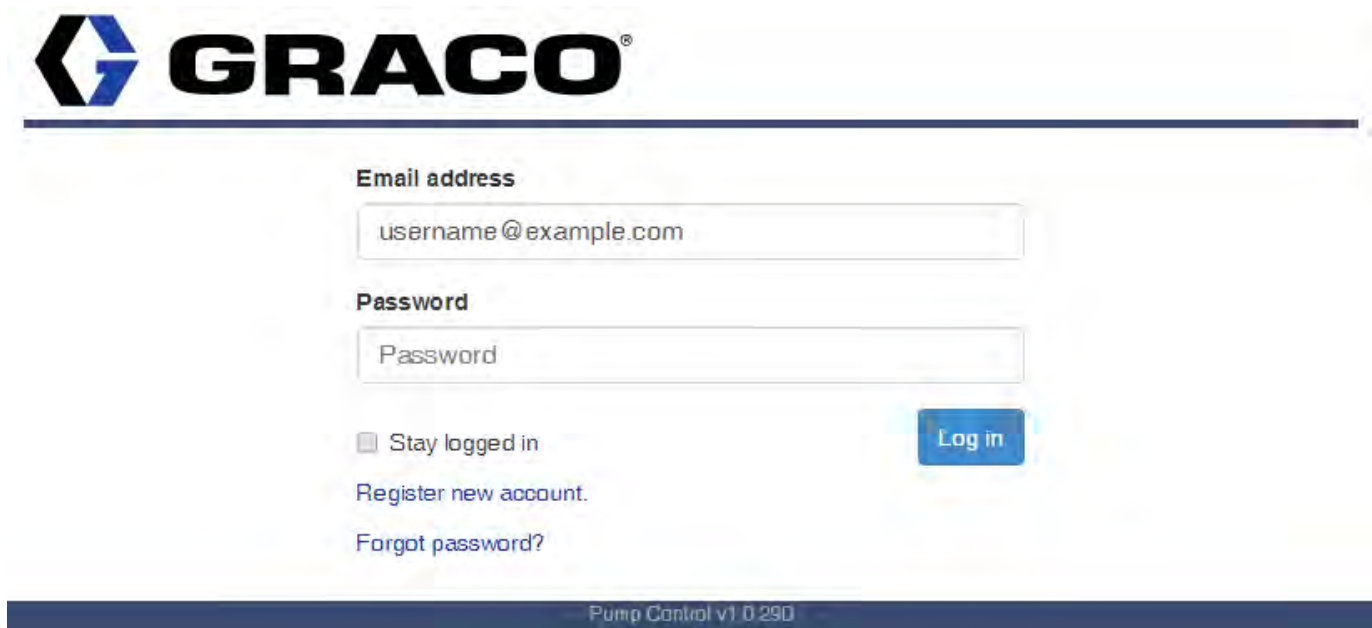
---

**FIG. 57: Activation Complete screen**

4. Click **Return to login page** to log in to the account.

## Logging In to the Web Portal

1. Go to <https://harrier.graco.com> to display the Graco login screen.



**GRACO**

Email address  
username@example.com

Password  
Password

Stay logged in

[Register new account.](#)

[Forgot password?](#)

Log in

Pump Control v1 0.290

**FIG. 58: Graco Login screen**

2. Enter your username and password.

**NOTE:** Uncheck the **Stay logged in** box for maximum security to prevent unintended users from accessing your account.

3. Click **Log in** to display the Pumps List screen.



**NOTE:** The Terms of Service screen is displayed the first time you log in with a new account. The Pumps List screen is displayed once you've read and agreed to the Terms of Service.



## Terms of service

You must read and agree to the updated Terms of Service shown below to continue using this site.

End User License Agreement (EULA)

Graco Inc. agrees to provide you access to and use of its Software, under the terms and conditions specified below:

Configuration

You agree to use this Software with at least the minimum hardware and software requirements as set forth in the product documentation.

License Grant

Graco grants you a license to use the Software. "Use" means storing, loading, installing, executing or displaying the Software. You may not modify the Software or disable any licensing or control features of the Software. You agree to use the Software only in conjunction with Graco hardware.

**FIG. 59: Terms of Service screen**

## Pumps List Screen

The Pumps List screen lists all of the available pumps in your group. The Pumps table features the following information:

- **Name** - This is the name of the pump within the group.
- **Group** - This is the name of pump's group, which is a user-defined collection or network of pumps and the users authorized to remotely view and control those pumps. It may be a company or a collection of users within a company. Group users are able to remotely view and control all pumps within the group. Refer to **Groups Detail Screen**, page 65.
- **Status** - This indicates whether the pump is running, on standby, offline, disabled by alarm, disabled by remote, or in power save mode.



[Pumps](#) [Groups](#) [Settings](#) [Help](#)

### Pumps

Name	Group	Status
<a href="#">Pump 1</a>	<a href="#">Example Group</a>	Standby

Pump Control v1.0.290

**FIG. 60: Pumps List screen**

You can view the status of any pump in the network by clicking the name of the pump. This will display the Pump Detail screen, which differs depending on whether the pump is connected or disconnected.

- If the pump is connected, the Pump Detail screen will display a variety of information about the pump.
- If the pump is disconnected, you will see the Pump Detail screen shown in FIG. 63.

## Pumps Detail Screen (Pump Connected)

The Pumps Detail screen displays the information available for a single connected pump. The information displayed below will vary depending on the pump metering mode. This screen is displayed when you click name of a connected pump on the Pumps List screen (FIG. 60).

The following information is available on this screen:

- **NAME** - This the name of the pump within the network. It can be edited by clicking the icon and entering a new name in the text box that appears.
- **STATUS** - This indicates the current network status of the pump. The icon can be used to toggle between Run and Standby. Putting the pump in Run mode will immediately start the pump. If the status indicates the pump has been disabled by an alarm, remote, or temperature, you will not be able to change the status until you reset the alarm in the ALARMS ACTIVE row.
- **ALARMS ACTIVE** - This indicates whether there are any active alarms for the pump. Any active alarms puts the pump into Standby mode, and the STATUS row will indicate that the pump is disabled by Alarm, Remote, or Temperature. You can reset active alarms by clicking the Reset icon in the Alarms Active row. The Reset icon only appears when an alarm is active.
- **METERING MODE** - This indicates whether the pump is running in Flow, Time, or Cycle mode. Some of the information on this screen is specific to a particular metering mode, and may not appear for all modes. The metering mode can only be changed from the Harrier+ controller on the Configuration screen. The information for each mode is listed below.

### Flow Mode

- **FLOW RATE** - This is the desired number of gallons or liters to be pumped per day. Becomes read only when analog is in enabled and changes to ANALOG FLOW RATE.
- **TOTALIZER** - This is the number of gallons pumped since last time the Totalizer was reset. The Totalizer is reset by clicking the icon.
- **GRAND TOTALIZER** - This the total number of gallons pumped since the pump was added to the network. It cannot be reset.

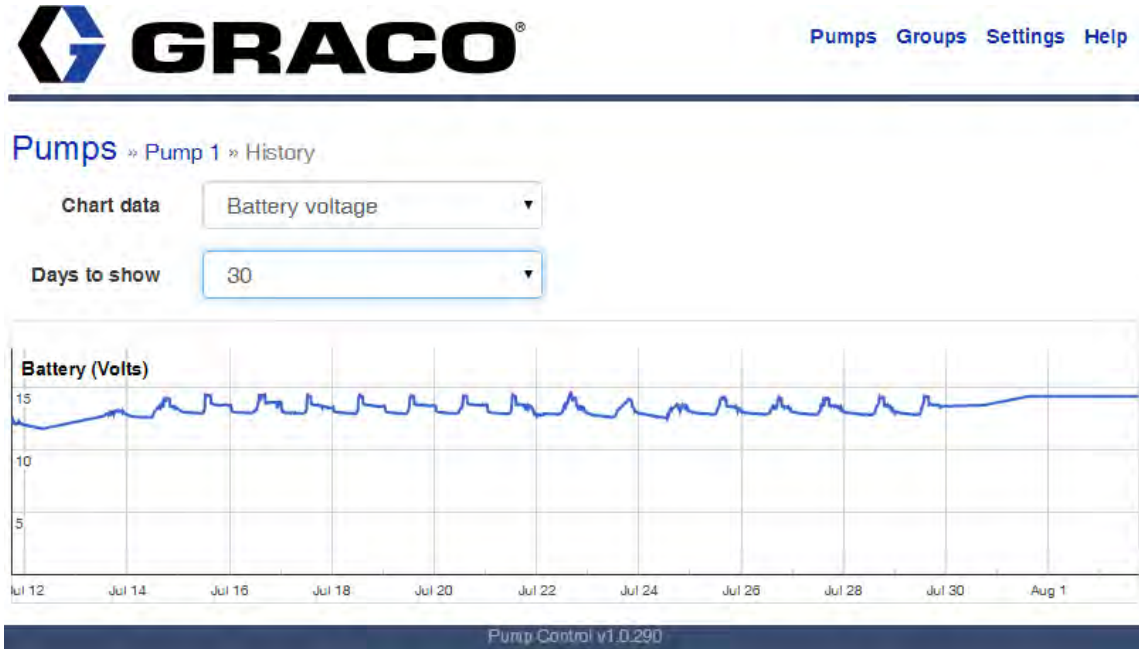
### Time Mode

- **ON TIME** - This is the desired amount of time the pump is to remain on.
- **OFF TIME** - This is the desired amount of time the pump is to remain off.

### Cycle Mode

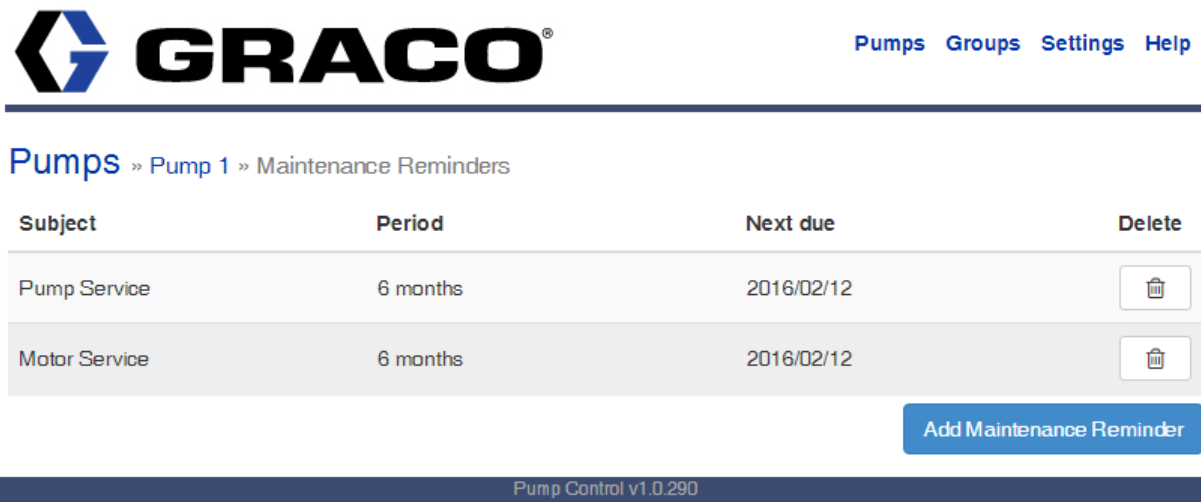
- **ON CYCLES** - This is the desired number of cycles the pump is to remain on.
- **ON TIMEOUT** - An alarm is triggered if a cycle is not detected within the time specified in the ON TIMEOUT field. This timer starts when the value in the OFF TIME field expires.
- **OFF TIME** - This is the desired amount of time the pump is to remain off after the desired number of cycles in the ON CYCLES field have completed.

- HISTORICAL CHARTS** - Clicking the icon displays the Historical Charts screen. For chart data, you may choose from Total pumped per day (the actual volume pumped, not the desired setting), Battery voltage, Fluid pressure, Monthly Report, Tank Level, or Temperature. For days to show, you may choose from the past 1, 7, 14, 30, or 90 days.



**Fig. 61: History Chart of Battery Voltage for 30 days**

- MAINTENANCE REMINDERS** - Clicking the icon displays the Maintenance Reminders screen, which allows you to add maintenance reminders; or lists any active reminders (such as Pump Service), their regularity, and when they are next due. Clicking Add Maintenance Reminder allows you to choose the type of reminder (Pump Service, Motor Service, Battery Service, and Chemical Tank Refill) and period (Immediate, or 1, 3, 6, 12, or 24 months). Reminders can also be customized by both subject and period (in months).



**Fig. 62: Maintenance Reminders screen**

**Power Save Mode** - These fields only appear when the Power Save mode is on. The following three fields (BATTERY VOLTAGE, POWER SAVE ON, and BATTERY SHUTOFF) will not appear when Power Save Mode is off.

- **BATTERY VOLTAGE** - Displays the current battery voltage if the optional battery monitor is connected.
- **POWER SAVE ON** - This is the battery voltage threshold at which Power Save mode is triggered. It can be edited by clicking the icon and entering a new voltage value in the text box that appears.
- **BATTERY SHUTOFF** - This is the battery voltage threshold for a low battery alarm to be triggered. It can be edited by clicking the icon and entering a new voltage value in the text box that appears.
- **PRESSURE LEVEL** - Displays the current pressure level if the optional pressure transducer is connected.
- **HIGH PRESSURE ALARM** - This is the pressure threshold for a high pressure alarm to be triggered. It can be edited by clicking the icon and entering a new pressure value in the text box that appears.
- **LOW PRESSURE ALARM** - This is the pressure threshold for a low pressure alarm to be triggered. It can be edited by clicking the icon and entering a new pressure value in the text box that appears.
- **TANK LEVEL** - Displays the current tank level.
- **LOW TANK NOTIFY** - Displays the low tank notify volume, the threshold for notify alarm to be triggered.
- **LOW TANK SHUTOFF** - Displays the low tank shutoff volume, the threshold for shutoff alarm to be triggered.
- **FLOW VERIFY PERCENTAGE** - Displays the maximum allowable correlation difference between the daily totalizer and daily tank level change. Only displayed if flow verify is enabled on controller.
- **TEMPERATURE** - The temperature is measured by the temp probe.
- **TEMP CONTROL** - Whether temp is disabled, display only, on above, or on below.
- **TEMP SETPOINT** - The temperature at which the pump turns on below or above this value. Only displayed if Temp control = on above or on below.
- **ALARM CUSTOMIZATION** - Allows the alarm #1, alarm #2, and auxiliary inputs to be custom named.
- **NETWORK** - This indicates whether the pump has network connectivity.
- **SIGNAL STRENGTH** - This is the network signal strength.
- **LOCATION** - This is a description of the pump's location. It can be edited by clicking the icon and entering a new location in the text box that appears.
- **MARKED LOCATION** - This is the longitude and latitude for the pump's location. This can be edited by the icon. You can either directly enter the longitude and latitude, or click the **Get Location** button to download your current coordinates. You can display a map view of your pump's location by clicking the coordinates. You must be next to the pump when you "Get Location".
- **GROUP** - This the name of group that was created or selected during account registration. Pumps are assigned to a group during account registration, or to an existing group at any time.

- **ACTIVATION KEY** - The Activation Key ties a pump (as identified by its Pump ID) to its assigned group. The Activation Key is generated at the pump by selecting "CELL" on the Network Setup screen. This field will only appear on this screen for group managers and administrators.
- **PUMP ID** - This is the Harrier+ controller's unique pump ID.
- **DOWNLOAD HISTORY** - Clicking the icon downloads a CSV file with a log of all data sent to and from the pump; such as, firmware updates, changes to settings, and status updates.
- **FIRMWARE VERSION** - This is the version number of the firmware running on the Harrier+ controller.

## Pumps Detail Screen (Pump Disconnected)

The Pumps Detail screen shown below is an example of the information available for a single disconnected pump. This screen is displayed when you click name of a disconnected pump on the Pumps List screen (FIG. 60).

The screenshot shows the GRACO web portal interface. At the top left is the GRACO logo. To the right are navigation links: Pumps, Settings, and Help. Below the logo is a breadcrumb trail: Pumps >> Pump 1. The main content area is a table with the following rows:

NAME	Pump 1	
HISTORICAL CHARTS		
MAINTENANCE REMINDERS		
NETWORK	Not connected	
LAST CONNECTED	2015-06-02 17:04:40 CDT	
PUMP ID	270113182612191782	

**FIG. 63: Pumps Detail screen (pump disconnected)**

The following information is available on this screen:

- **NAME** - This is the name of the pump within the network. It can be edited by clicking the icon and entering a new name in the text box that appears.
- **HISTORICAL CHARTS** - Clicking the icon displays the Historical Charts screen. For chart data, you may choose from Volume per Day, Battery, or Pressure. For days to show, you may choose from the past 1, 7, 14, 30, or 90 days.
- **MAINTENANCE REMINDERS** - Clicking the icon displays the Maintenance Reminders screen, which lists any active reminders, such as Pump Service, their regularity, and when they are next due. Clicking Add Maintenance Reminder allows you to choose the type of reminder (Pump Service, Motor Service, Battery Service, and Chemical Tank Refill) and period (Immediate, or 1, 3, 6, 12, or 24 months).
- **NETWORK** - This indicates whether the pump has network connectivity.
- **LAST CONNECTED** - This is the last date and time the Harrier+ controller had network connectivity.
- **PUMP ID** - This is the Harrier+ controller's unique pump ID.

## Groups List Screen

The Groups List screen displays the groups you belong to. This screen is displayed when you click the Groups link at the top of any screen.



[Pumps](#) [Groups](#) [Settings](#) [Help](#)

### Groups

Name	Pump count	User count
<a href="#">Example Group</a>	1	1

[Create group](#)

Pump Control v1.0.290

**FIG. 64: Groups List screen**

The following information is available on this screen:

- **Name** - This the name of all the groups you belong to. You can click any name to display a Groups Detail screen for the group (FIG. 65).
- **Pump count** - The number of pumps currently in a group.
- **User count** - The number of users currently in a group.



## Groups Detail Screen

The Groups Detail screen displays information about a group, including the group’s manager, members, and pump. This screen is displayed by clicking the name of a group on the Groups List screen (FIG. 64).



**FIG. 65: Group Detail screen**

The following information is available on this screen:

- **NAME** - This the name of the group. It can be edited by clicking the icon and entering a new name in the text box that appears.
- **MANAGER** - This is email address of the group’s manager. They can edit exiting group fields, as well as add and delete users and pumps.
- **USERS** - Users can remotely view and control all pumps associated with the group. Click the icon to display a list of existing group users. Managers can use this screen to invite new users to the group and to remove existing users.



**FIG. 66: Group User List screen**

- **PUMPS** - Pumps associated with the group can be viewed and controlled by users in the group. Click the icon to display a list of all pumps associated with the group. Managers can use this screen to add and remove associated pumps.



**FIG. 67: Groups Pumps screen**

## Invitation to Join a Group

If you want to join an existing group, the group manager can send you an invitation to join the group. You will receive an email from Graco inviting you to join the group. Click the link in the email to accept the invitation and display the Invitation screen shown in FIG. 68.



**FIG. 68: Accept Invitation screen**

Once you have accepted the invitation, you are able to remotely view and control all of the pumps in all of your groups. These pumps are added to your Pumps List screen.



**FIG. 69: Pumps List screen after new group invitation**

## Settings Screen

The Settings screen allows you to view and edit your user settings. This screen is displayed when you click the Settings link at the top of any screen.



[Pumps](#) [Groups](#) [Settings](#) [Help](#)

Users » [username@example.com](#)

EMAIL	username@example.com	
PASSWORD		
FIRST NAME	John	
LAST NAME	Smith	
TIME ZONE	UTC	
DISPLAY UNITS	U.S.	
SHOW DISCONNECTED PUMPS	Yes	<input checked="" type="checkbox"/>
ENABLE REMINDERS	Yes	<input checked="" type="checkbox"/>
MAINTENANCE REMINDERS		
GROUPS	<a href="#">Example Group</a>	

[Log out](#)

Pump Control v1.0.290

**FIG. 70: Users screen**

The following information is available on this screen:

- **EMAIL** - This is the email address associated with your username. You can edit this by clicking the icon and entering a new email address in the text box that appears.

- **PASSWORD** - This is your login password. You can edit this by clicking the icon and entering a new password in the text box that appears.
- **FIRST NAME** - Your first name.
- **LAST NAME** - Your last name.
- **TIME ZONE** - This is your time zone. You can edit this by clicking the icon and selecting another time zone from the drop-down menu that appears.
- **DISPLAY UNITS** - This indicates what units of measurement are used on screens and charts. You can edit this by clicking the icon and selecting either US or Metric from the drop-down menu that appears.
- **SHOW DISCONNECTED PUMPS** - This indicates whether the Pump List screen defaults to including disconnected pumps. You can toggle between Yes and No by clicking the icon.
- **ENABLE REMINDERS** - This indicates whether maintenance reminders are enabled. You can toggle between Yes and No by clicking the icon.
- **MAINTENANCE REMINDERS** - Clicking the icon displays the Maintenance Reminders screen, which lists any active reminders, such as Pump Service, their regularity, and when they are next due. Clicking Add Maintenance Reminder allows you to choose the type of reminder (Pump Service, Motor Service, Battery Service, and Chemical Tank Refill) and period (Immediate, or 1, 3, 6, 12, or 24 months).
- **GROUPS** - The groups you belong to.

## Help Screen

The Help screen directs to you resources for additional information about technical support, related products, and patent information. This screen is displayed when you click the Help link at the top of any screen.



[Pumps](#) [Groups](#) [Settings](#) [Help](#)

### Help

#### Technical support

If you have questions or encounter problems while using the web site, please contact us at [oilandgas@graco.com](mailto:oilandgas@graco.com).

#### Related products

Graco offers a wide array of related products and services. For more information, please visit the [main Graco web site](#).

#### Patent information

For patent information, see [www.graco.com/patents](http://www.graco.com/patents).

#### Terms of Service

Use of this site is subject to the [Terms of Service](#).

Pump Control v1.0.290

**FIG. 71: Help screen**

# Troubleshooting



Description	Problem	Solution
Unit does not power on or display is dim/unresponsive	Incorrect or loose wiring	Refer to <b>Installation</b> , page 9.
	Input voltage is out of range	Confirm power source is with the correct range.
	Tripped external fuse	Verify proper connections. Refer to <b>Installation</b> , page 9.
	Incorrect operating temperature	Verify ambient temperature is within recommended operating conditions.
Pressure transducer reading not working or inaccurate	Pressure transducer not calibrated	Refer to the <b>Fluid Pressure Screen</b> , page 46, for calibration information.
	Pressure transducer faulty	Replace pressure transducer
Pump not running	No power	Check wiring. Refer to <b>Installation</b> , page 9.
	There is an alarm	Check alarms. Refer to <b>Alarms and Signal Events</b> , page 51.
	Other	See Wolverine Chemical Injection Pump manual (334513).
Battery monitor not working	Not connected	Check wiring. Refer to <b>Installation</b> , page 9.
	Battery voltage too low	Check battery and wiring to the solar panel.
	Not enabled	Check setup screens. Refer to the <b>Alarms Setup Screen</b> , page 38.
Not connecting to a cell network	No signal	Check antenna orientation and mounting. Make sure antenna is pointing upwards towards sky. Make sure device is not located in a concrete building or near other interfering devices.
		Verify antenna cables are connected. Use only the antenna provided. Refer to <b>Antenna Connection</b> , page 9.
		Check cell service in the area. Consider high gain antenna kit.
	Incorrect network mode	Select CELL on the <b>Network Setup Screen</b> , page 44, and turn power to the controller Off and On.
	Modem not supported	Verify correct controller model for cell networks. Refer to <b>Models</b> , page 3.

Description	Problem	Solution
Not connecting to a SCADA network	Incorrect network mode	Select MODBUS on the <b>Network Setup Screen</b> , page 44, and turn power to the controller Off and On.
	Incorrect slave ID or Serial Port Settings	Verify the correct slave ID and serial port settings have been assigned to the controller on the <b>Network Setup Screen</b> , page 44, and turn power to the controller Off and On.
	Incorrect registers or values sent to the controller	Refer to <b>Appendix A: Modbus Interface</b> , page 76, for details on interfacing with the controller.
	Incorrect wiring	Check wiring. Refer to <b>Installation</b> , page 9, and verify the proper user-provided gateway adapter is connected correctly.

## Cellular Connection Status Codes

The Network Setup screen (see page 44) displays a status code while the modem is connecting to the cellular network with the current status code in parentheses (see FIG. 39 on page 44). These codes provide detail on which step the modem is currently on, but do not necessarily imply that an error is present. The modem will continue to retry the steps below until a connection to the cellular network is established. All steps will resolve themselves automatically with no user action; however, certain steps can be taken if the modem remains on the same step for an extended amount of time, as explained in the table below.

Status Code No.	Description	Explanation / Solution
1	Connection In Progress Status Code	Modem is trying to connect to the cellular network and will continue trying until a connection is established. No action is required.
2	AT Status Code	Modem is responding with an error or unexpected response. Cycle power.
3	Configuration Verbosity Status Code	Modem reported an error while enabling verbose error messages. Cycle power.
4	Signal Strength Status Code	Modem cannot detect a cell signal. Check cell service, antenna and antenna cables, try a high gain antenna, or cycle power.
5	Unique ID Status Code	Unable to retrieve the pump ID from the modem. Cycle power.
6	Registration Status Code	Modem is unable to register on the cellular network. Check cell service, antenna and antenna cables, try a high gain antenna, or cycle power.
7	Open Data Status Code	Modem is unable to open a data connection on the cellular network. Check cell service, antenna and antenna cables, try a high gain antenna, or cycle power.
8	Open Socket Status Code	Modem is unable to connect to the server. Check cell service, antenna and antenna cables, try a high gain antenna, or cycle power.
9	Location Status Code	Modem is unable to get the location. No action is required. Modem will automatically skip this error and retry.
10	SSL Status Code	Modem is unable to establish a secure connection and therefore, will not connect to the cellular network. Cycle power.

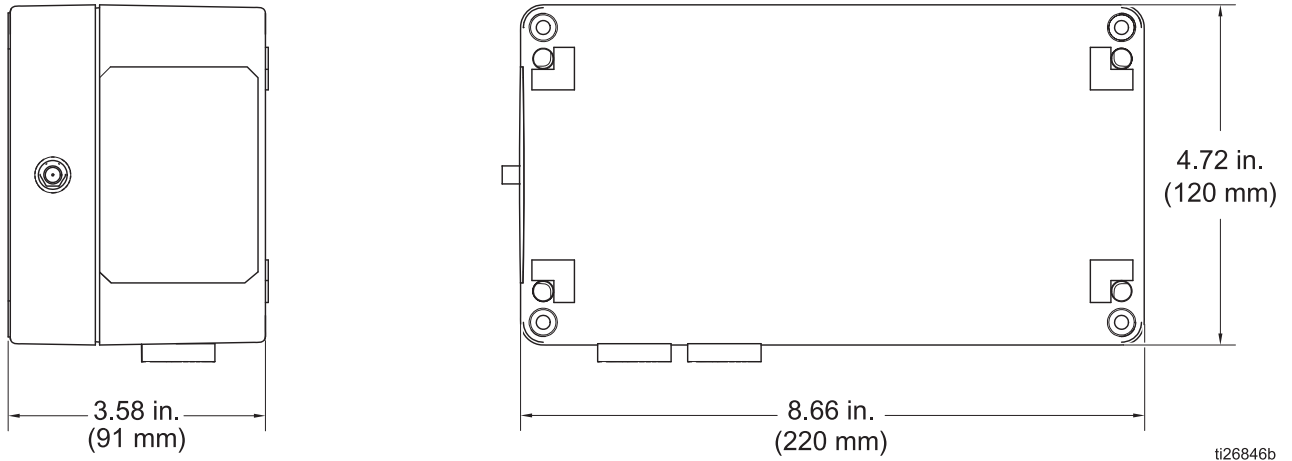


## Program Settings

Description	Page	Modes of Operation, Maximums / Minimums, and Additional Comments
Pump Modes	34-37	Flow, Time, Cycle
Flow Rate (Flow Mode)	34-36	0.1 - 600.0 GPD / 2,271.0 LPD. Restricted by K-Factor. Will automatically re-adjust value entered if K-Factor isn't large enough to support flow rate entered.
KFactor (Flow & Cycle Modes)	37-35	1 - 9999
Interval (Flow Mode)	34	Short, Medium, Long
Cycle SW (Flow Mode)	35	Yes, No
On Time Off Time Timeout (Time or Cycle Mode)	35	HH:MM:SS (00:00:01 - 99:59:59)
On Cycles (Cycle Mode)	37	01 - 99
Alarm Type	38-40	Control, Battery, Pressure, Tank, Temp, Motor
Alarm Action	38	Stop, Notify
Input 1 (Alarm Screen: Control)		Disabled, Normally Closed, Normally Open
Input 2 (Alarm Screen: Control)		Disabled, Normally Closed, Normally Open
Remote Off/Auxiliary Switch (Alarm Screen: Control)		Disabled, Normally Closed, Normally Open
Power Savings (Alarm Screen: Battery)	39	Off, Notify, Min, Normal, Max
Power Save On (Alarm Screen: Battery)		000.0 V - 999.9 V
Battery Shutoff (Alarm Screen: Battery)		000.0 V - 999.9 V
High Pressure Trigger (Alarm Screen: Pressure)		00000 - 99999 PSI
Low Pressure Trigger (Alarm Screen: Pressure)		00000 - 99999 PSI
Tank Alarms (Alarm Screen: Tank)		See Tank Level Setup
Control (Alarm Screen: Temp)		40
Setpoint (Alarm Screen: Temp)	-40°F - 118°F	
Protection (Alarm Screen: Motor)	42	On, Off
Voltage (Alarm Screen: Motor)		12 VDC, 24 VDC, 115 VAC, 230 VAC
Motor PN (Alarm Screen: Motor)		List of motor PN's, varies depending on voltage selected
PIN Number Setup		Enabled, Disabled
PIN Code Entry		0000 - 9999
Network Type	43	None, Cell, Modbus

Description	Page	Modes of Operation, Maximums / Minimums, and Additional Comments
Slave ID (Network Type: Modbus)	44	1-247
Baud (Network Type: Modbus)		9,600 bits/sec, 19,200 bits/sec, 57,600 bits/sec, 115,200 bits/sec
Parity (Network Type: Modbus)		None, Odd, Even
Stop (Network Type: Modbus)		One, Two
Calibration (Network Type: Modbus)		Stop, Start. Updates K-Factor.
Cal Volume	44	000.0 to 999.99 CC
Units	45	US: Gallons per day / PSI / Inches
		Metric: Liters per day / BAR / Centimeters
		Off/Flow
Analog In		Off/Flow
Low Setpoint (Analog In: Flow)		4.00 mA – 20.00 mA
Low mA Flow (Analog In: Flow)	46	See Flow Rate
High Setpoint (Analog In: Flow)		4.00 mA – 20.00 mA
High mA Flow (Analog In: Flow)		See Flow Rate
Analog Out	47	Off, On
Min Out (Analog Out: On)		0.0 – 5.9V
Max Out (Analog Out: On)		0.0 – 5.9V
Pressure transducer offset	48	00.00 to 99.99. Located on pressure transducer label. Used to calibrate pressure transducer.
Pressure transducer sensitivity		00.00 to 99.99. Located on pressure transducer label. Used to calibrate pressure transducer.
Tank Level		See Tank Level Setup

# Dimensions and Mounting Hole Layout



ti26846b

**FIG. 72: Harrier+ Dimensions and Mounting Hole Layout**

## Kits and Accessories

Part	Description
B32788	Standard Antenna Kit
B32699	High-Gain Antenna Kit
B32072	Line Pressure Sensor (6000 PSI)
B32771	Tank Level Monitor Kit
B32088	Calibration Column Kit (316 SST)
B32208	Calibration Column Kit (303 SST)
B32089	Tank Manifold with Calibration Column and Filter Kit (316 SST)
B33006	Analog Out
17G743	Antenna Wire/ Bulkhead
B32874	RS232 to RS485 Converter
B32989	Lug Style Temperature Probe
B32131	Barrel Style Temperature Probe
24X261	Token, Upgrade

# Appendix A: Modbus Interface

## PC Interface

If desired, you can connect a PC to your controller by providing an adapter between the PC and the RS232 SCADA Interface cable (see K in FIG. 4 and FIG. 6). Your serial port must be configured to match the PC.

- Comm Port = COM1
- Baud Rate = 115200, 57600, 19200, 9600
- Data Bits = 8
- Parity = None, Odd, Even
- Stop Bits = 1, 2
- Flow Control = None

The serial port settings are configurable & must be set before any communication to the controller is started. See Fig. 44. Power must be cycled on the controller after changing the slave ID.

## PLC Interface

Gateway adapters to the controller's RS232 SCADA interface (see K in FIG. 4 and FIG. 6) must be provided by user to support other protocols (see RS485 converter kit and wiring diagrams).

- Communication Mode: ModBus RTU/RS232
- Byte Order: Most Significant Byte (MSB) First
- 32-Bit Registers: Read 2 (16-bit) registers per parameter
- 16-Bit Registers: Read 1 (16-bit) register per parameter
- ModBus Register Offset: Protocol address = Modbus Register - 400001
- IE: Pump Status Modbus Register = 401004 and protocol address = 1003
- Comm Port Settings: Settings on the Harrier+ must match settings on the PLC
- See PC interface for configurable comm port settings.

The following tables list Modbus registers available to a PC or PLC. This map is subject to change depending on firmware revision. Contact customer service for the correct map for your specific firmware revision.

## Variable Maps

The following tables list Modbus registers available to a PC or PLC.

**Table 2: Harrier+ Modbus Read Parameters**

Modbus Register	Parameter Name	Data Type	Units	Range	Resolution	R/W Access	Notes
401000	Pressure PSI	uint32	PSI or BAR	0-14,000	1 PSI or .1 BAR	READ_ONLY	Val = Range x Resolution  Pressure sensor equipped units only
401002	Battery Milli-volts	uint32	mV	0-50,000	1mV or 0.001V	READ_ONLY	Val = Range x Resolution
401004	Pump Status	uint32	NA	0-3  0: = Standby 1: = Run 2: = Lockout Alarm 3: = Lockout Remote		READ_ONLY	
401006	Cycle Progress	uint32	%	0-100	1%	READ_ONLY	
401008	Total	uint32	Gal or Liter	0-0xFFFFFFFF	.01 Gal or .1 Liter	READ_ONLY	Val = Range x Resolution  Applies to Flow Mode only
401010	Grand Total	uint32	Gal or Liter	0-0xFFFFFFFF	.01 Gal or .1 Liter	READ_ONLY	Val = Range x Resolution  Applies to Flow Mode only
401012	Alarm Bitfield	uint32	NA	0-0xFFFFFFFF  Bit 0: Unused Bit 1: Low Tank Shutoff Bit 2: Low Tank Notify Bit 3: Analog In Bit 4: Modbus Comms Bit 5: Flow Accuracy Bit 6: Count Not Achieved Bit 7: Input 1 Bit 8: Input 2 Bit 9: Temperature Bit 10: Battery Shutoff Bit 11: Not Used Bit 12: High Pressure Bit 13: Low Pressure Bit 14: Over Current		READ_ONLY	
401014	Remote Disable Active	uint32	NA	0-0xFF  0: =FALSE 1: =TRUE		READ_ONLY	Default Val = 0xFF until 1st change in aux input is detected
401016	Tank Level	uint32	Gal or Liter	0-99,999 (Gal)	.1 Gal or .1 Liter	READ_ONLY	Val = Range x Resolution  TLM equipped units only

Modbus Register	Parameter Name	Data Type	Units	Range	Resolution	R/W Access	Notes
401018	Analog Flow Rate		Gal or Liter	10-60,000 (Gal)	.01 Gal or .1 Liter	READ_ONLY	Val = Range x Resolution  Use instead of desired flow rate when Analog In is enabled.
401020	Alarm Action	uint32	NA	0-1 0: = Stop 1: = Notify	NA	READ_ONLY	
401022	Metering Mode	uint32		0-2 0: = Flow 1: = Time 2: = Cycles	NA	READ_ONLY	
401024	On Time	uint32	Sec-onds	1-359,999 (0x57E3F)	1 sec	READ_ONLY	Max is 99 Hr, 59 min, 59 sec  Time Mode Only
401026	Off Time	uint32	Sec-onds	1-359,999 (0x57E3F)	1 sec	READ_ONLY	Max is 99 Hr, 59 min, 59 sec  Time Mode Only
401028	On Cycles	uint32	Cycles	0-99 (0-0x63)	1 cycle	READ_ONLY	Cycle Mode Only
401030	On Timeout	uint32	Sec-onds	1-359,999 (0x57E3F)	1 sec	READ_ONLY	Max is 99 Hr, 59 min, 59 sec  Flow and Cycle Mode
401032	Power Save Mode	uint32	NA	0-4 0: = Power Save Off 1: = Power Save Notify 2: = Power Save Min 3: = Power Save Normal 4: = Power Save Max	NA	READ_ONLY	
401034	Units	uint32	NA	0-1 0: = Imperial 1: = Metric	NA	READ_ONLY	
401036	Pressure Offset	uint32	NA	0-0x7FFFFFFF	NA	READ_ONLY	Pressure sensor equipped units only
401038	Pressure Slope	uint32	NA	0-0x7FFFFFFF	NA	READ_ONLY	Pressure sensor equipped units only
401040	K-Factor	uint32	NA	1-9,999	1 count	READ_ONLY	Flow Mode Only
401042	Desired Flow Rate	uint32	Gal or Liter	10-60,000 (Gal)	.01 Gal or .1 Liter	READ_ONLY	Use when Analog In is disabled  Flow Mode Only
401044	Software Version	uint32	NA	0-0xFFFFFFFF	NA	READ_ONLY	0X00xyyzz, where  xx = major yy = minor zz = build

Modbus Register	Parameter Name	Data Type	Units	Range	Resolution	R/W Access	Notes
401046	High Pressure Trigger	uint32	PSI or BAR	0-99,999	1 PSI or .1 BAR	READ_ONLY	Val = Range x Resolution Pressure sensor equipped units only
401048	Low Pressure Trigger	uint32	PSI or BAR	0-99,999	1 PSI or .1 BAR	READ_ONLY	Val = Range x Resolution Pressure sensor equipped units only
401050	Power Save Turn On	uint32	mV	0-99,999	1 mV or 0.001V	READ_ONLY	Val = Range x Resolution
401052	Battery Shut-off	uint32	mV	0-99,999	1 mV or 0.001V	READ_ONLY	Val = Range x Resolution
401054	Alarm 1 Trigger Type	uint32	NA	0-2 0: = Disabled 1: = Normally Closed 2: = Normally Opened	NA	READ_ONLY	
401056	Alarm 2 Trigger Type	uint32	NA	0-2 0: = Disabled 1: = Normally Closed 2: = Normally Opened	NA	READ_ONLY	
401058	Remote Off Trigger Type	uint32	NA	0-2 0: = Disabled 1: = Normally Closed 2: = Normally Opened	NA	READ_ONLY	
401060	Volume Mode Interval	uint32	NA	0-2 0: = Interval 1 Minute 1: = Interval 5 Minute 2: = Interval 10 Minute	NA	READ_ONLY	Flow Mode Only
401062	Tank Level Notify Trigger	uint32	Gal or Liter	0-99,999 (Gal)	.1 Gal or .1 Liter	READ_ONLY	TLM equipped units only.
401064	Tank Level Shutoff Trigger	uint32	Gal or Liter	0-99,999 (Gal)	.1 Gal or .1 Liter	READ_ONLY	TLM equipped units only.
401066	Flow Verify Enable	uint32	NA	0-1 0: = Disabled 1: = Enabled	NA	READ_ONLY	SCADA program must write custom alarm if desired
401068	Flow Verify Percentage	uint32	%	0-999	1%	READ_ONLY	SCADA program must write custom alarm if desired
401070	Max Tank Volume	uint32	Gal or Liter	0-99,999 (Gal)	.1 Gal or .1 Liter	READ_ONLY	Val = Range x Resolution TLM equipped units only.
401072	Analog Flow Rate Low mA Setpoint	uint32	Gal or Liter	10-60,000 (Gal)	.01 Gal or .1 Liter	READ_ONLY	Val = Range x Resolution Analog In must be enabled

Modbus Register	Parameter Name	Data Type	Units	Range	Resolution	R/W Access	Notes
401074	Analog Flow Rate High mA Setpoint	uint32	Gal or Liter	10-60,000 (Gal)	.01 Gal or .1 Liter	READ_ONLY	Val = Range x Resolution Analog In must be enabled
401076	Analog In Control	uint32	NA	0-1 0: = Off 1: = Flow	NA	READ_ONLY	
401078	Analog Control Low mA Setpoint	uint32	mA	400-2,000	.01mA	READ_ONLY	Val = Range x Resolution ie: 4 to 20mA Analog In must be enabled
401080	Analog Control High mA Setpoint	uint32	mA	400-2,000	.01mA	READ_ONLY	Val = Range x Resolution ie: 4 to 20mA Analog In must be enabled

**Table 3: Harrier+ Modbus Write Parameters**

Modbus Register	Parameter Name	Data Type	Units	Range	Resolution	R/W Access	Notes
401082	Pump Status	uint32	NA	0-1 Writeable 0-3 Readable 0: = Standby 1: = Run 2: = Lockout Alarm 3: = Lockout Remote	NA	READ_WRITE	
401084	Alarm Action	uint32	NA	0-1 0: = Stop 1: = Notify	NA	READ_WRITE	
401086	Metering Mode	uint32		0-2 0: = Flow 1: = Time 2: = Cycles	NA	READ_WRITE	Set & returns 0 if out of range Flow Mode only
401088	On Time	uint32	Sec-onds	1-359,999 (0-0x57E3F)	1 sec	READ_WRITE	Time Mode Only
401090	Off Time	uint32	Sec-onds	1-359,999 (0-0x57E3F)	1 sec	READ_WRITE	time Mode Only
401092	On Cycles	uint32	Cycles	0-99 (0-0x63)	1 cycle	READ_WRITE	Cycle Mode Only
401094	On Timeout	uint32	Sec-onds	1-359,999 (0-0x57E3F)	1 sec	READ_WRITE	Flow and Cycle Mode
401096	Power Save Mode	uint32	NA	0-4 0: = Power Save Off 1: = Power Save Notify 2: = Power Save Min 3: = Power Save Normal 4: = Power Save Max	NA	READ_WRITE	Set & returns 3 if out of range



Modbus Register	Parameter Name	Data Type	Units	Range	Resolution	R/W Access	Notes
401098	Units	uint32	NA	0-1 0: = Imperial 1: = Metric	NA	READ_WRITE	Set & returns 0 if out of range
401100	Pressure Offset	uint32	mV/V	0 - 0x7FFFFFFF	0.01 mV/V	READ_WRITE	
401102	Pressure Slope	uint32	mV/V	0 - 0x7FFFFFFF	0.01 mV/V	READ_WRITE	
401104	K-Factor	uint32	NA	1-9,999	1 count	READ_WRITE	Coerced to range if out of range, < 1 goes to 1 & > 9,999 goes to 9,999
401106	Desired Flow Rate	uint32	Gal or Liter	10-60,000 (Gal)	.01 Gal or .1 Liter	READ_WRITE	Clamps to min and max if out of range  Flow Mode Only with Analog In disabled
401108	High Pressure Trigger	uint32	PSI or Bar	0-99,999	1	READ_WRITE	Pressure sensor equipped units only
401110	Low Pressure Trigger	uint32	PSI or Bar	0-99,999	1	READ_WRITE	Pressure sensor equipped units only
401112	Power Save Turn On	uint32	mV	0-99,999	1 mV or 0.001V	READ_WRITE	
401114	Battery Shut-off	uint32	mV	0-99,999	1 mV or 0.001V	READ_WRITE	
401116	Alarm 1 Trigger Type	uint32	NA	0-2 0: = Disabled 1: = Normally Closed 2: = Normally Opened	NA	READ_WRITE	Set & returns 0 if out of range
401118	Alarm 2 Trigger Type	uint32	NA	0-2 0: = Disabled 1: = Normally Closed 2: = Normally Opened	NA	READ_WRITE	Set & returns 0 if out of range
401120	Remote Off Trigger Type	uint32	NA	0-2 0: = Disabled 1: = Normally Closed 2: = Normally Opened	NA	READ_WRITE	
401122	Volume Mode Interval	uint32	NA	0-2 0: = Short Interval 1 Minute 1: = Medium Interval 5 Minute 2: = Long Interval 10 Minute	NA	READ_WRITE	Set & returns 0 if out of range.  Flow Mode Only.
401124	Tank Level Notify Trigger	uint32	Gal or Liter	0-9,999	.1 Gal or .1 Liter	READ_WRITE	TLM equipped units only

Modbus Register	Parameter Name	Data Type	Units	Range	Resolution	R/W Access	Notes
401126	Tank Level Shutoff Trigger	uint32	Gal or Liter	0-9,999	.1 Gal or .1 Liter	READ_WRITE	TLM equipped units only
401128	Flow Verify Enable	uint32	NA	0-1 0: = Disabled 1: = Enabled	NA	READ_WRITE	Sets & returns 0 if out of range  SCADA program must write custom alarm if desired
401130	Flow Verify Percentage	uint32	%	0-200	1%	READ_WRITE	SCADA program must write custom alarm if desired
401132	Analog Flow Rate Low mA Setpoint	uint32	Gal or Liter	10-60,000(Gal)	.01 Gal or .1 Liter	READ_WRITE	Analog In must be enabled
401134	Analog Flow Rate High mA Setpoint	uint32	Gal or Liter	10-60,000(Gal)	.01 Gal or .1 Liter	READ_WRITE	Analog In must be enabled
401136	Analog In Control	uint32	NA	0-1 0: = Off 1: = Flow	NA	READ_WRITE	
401138	Analog Control Low mA Setpoint	uint32	mA	400-2,000	.01 mA	READ_WRITE	Must be less than High mA set-point, invalid inputs will be clamped between 4mA and the High mA Setpoint-1 Analog In must be enabled
401140	Analog Control High mA Setpoint	uint32	mA	400-2,000	.01 mA	READ_WRITE	Must be greater than Low mA setpoint+1, invalid inputs will be clamped between the Low mA Setpoint and 20 mA Analog In must be enabled

**Table 4: Reset Parameters**

Modbus Register	Parameter Name	Data Type	Units	Range	Resolution	R/W Access	Notes
401142	Totalizer Reset	uint32	NA	0-1 0: = FALSE 1: = TRUE	NA	WRITE ONLY	Reset Totalizer  Must write 1 to reset the totalizer
401144	Clear Alarms	uint32	NA	0-1 0: = FALSE 1: = TRUE	NA	WRITE ONLY	Reset Clear Alarm Status  Must write 1 to reset the alarms

**Table 5: 16 Bit Registers**

Modbus Register	Parameter Name	Data Type	Units	Range	Resolution	R/W Access	Notes
401146	Battery Milli-volts Upper Word	uint16	mV	Unused	NA	READ ONLY	
401147	Battery Milli-volts Lower Word	uint16	mV	0-50000	1mV or 0.001V	READ ONLY	Val = Range x Resolution
401148	Alarm Bitfield Upper Word	uint16	NA	Unused	NA	READ ONLY	
401149	Alarm Bitfield Lower Word	uint16	NA	0-0xFFFFFFFF Bit 0: Unused Bit 1: Low Tank Shutoff Bit 2: Low Tank Notify Bit 3: Analog In Bit 4: Modbus Comms Bit 5: Flow Accuracy Bit 6: Count Not Achieved Bit 7: Input 1 Bit 8: Input 2 Bit 9: Temperature Bit 10: Battery Shutoff Bit 11: Not Used Bit 12: High Pressure Bit 13: Low Pressure Bit 14: Over Current	NA	READ ONLY	
401150	Tank Height Upper Word	uint16	Inches or cm	Unused	NA	READ ONLY	
401151	Tank Height Lower Word	uint16	Inches or cm	0-14,400 (Inches)	0.01 Inches or 0.1 cm	READ ONLY	Val = Range x Resolution Val = Height in Inches (not gallons)  TLM equipped units only
401152	K-factor Upper Word	uint16	NA	Unused	1 count	READ ONLY	
401153	K-factor Lower Word	uint16	NA	1-99,99	1 count	READ ONLY	Flow Mode Only
401154	Pump Status Upper Word	uint16	NA	Unused	NA	READ ONLY	

Modbus Register	Parameter Name	Data Type	Units	Range	Resolution	R/W Access	Notes
401155	Pump Status Lower Word	uint16	NA	0-1 Writable 0-3 Readable  0: = Standby 1: = Run 2: = Lockout Alarm 4: = Lockout Remote	NA	READ ONLY	
401156	Grand Total 16-Bit	uint16	Gal or Liter	0-32,767 (Gal)	.01 Gal or .1 Liter	READ_WRITE	Val = Range x Resolution Val rolls back to 0 at 32,767  Flow Mode only
401157	Desired Flow Rate	uint16	Gal or Liter	10-60,000 (Gal)	.01 Gal or 0.1 Liter	READ_WRITE	Val = Range x Resolution  Flow Mode only with Analog In disabled
401158	Pump Status Inhibit	uint16	NA	0-1 Writeable  0: = Run 1: = Standby	NA	READ_WRITE	Opposite of Pump Status
401159	Clear Alarm Status	uint16	NA	0-1  0: = FALSE 1: = TRUE	NA	WRITE ONLY	
401160	Update Heartbeat Tick	uint16	NA	0-0xFFFF	NA	READ_WRITE	Write any value to this register to increment heartbeat counter if modbus comms alarm is enabled
401161	Modbus Comms Enable	uint16	NA	0-1  0: = Disabled 1: = Enabled	NA	READ_WRITE	
401162	Tank Height Notify Trigger	uint16	Inches or cm	0-14,400 (Inches)	0.01 Inches or 0.1 cm	READ_WRITE	Coerced to range if out of range, > 14400, set to 14400 & < 0, set to 0  Val = Height in Inches  TLM equipped units only
401163	Tank Height Shutoff Trigger	uint16	Inches or cm	0-14,400 (Inches)	0.01 Inches or 0.1 cm	READ_WRITE	Coerced to range if out of range, > 14400, set to 14400 & < 0, set to 0  Val = Height in Inches  TLM equipped units only

**Table 6: Analog Output Registers**

Modbus Register	Parameter Name	Data Type	Units	Range	Resolution	R/W Access	Notes
401164	Analog Out Control	uint32	NA	0-1 0: = OFF 1: = ON	NA	READ_ONLY	
401166	Aout Min Out	uint32	Volts	0-59	0.1 Volts	READ_ONLY	Val = Range x Resolution Only when Analog Out is enabled
401168	Aout Max Out	uint32	Volts	0-59	0.1 Volts	READ_ONLY	
401170	Aout Type	uint32	NA	0-14 0: = Volts 1: = MA	NA	READ_ONLY	
401172	Analog Out Control	uint32	NA	0-2 0: = OFF 1: = ON	NA	READ_WRITE	
401174	Aout Min Out	uint32	Volts	0-59	0.1 Volts	READ_WRITE	Val = Range x Resolution Only when Analog Out is enabled
401176	Aout Max Out	uint32	Volts	0-59	0.1 Volts	READ_WRITE	Val = Range x Resolution Only when Analog Out is enabled

**Table 7: Temperature Registers**

Modbus Register	Parameter Name	Data Type	Units	Range	Resolution	R/W Access	Notes
401178	Temperature	uint32	°F or °C	-40 to 118 (°F)	1 °	READ_ONLY	
401180	TempControl	uint32	NA	0-3 0: = DISABLED 1: = DISPLAY 2: = ON BELOW 3: = ON ABOVE	NA	READ_ONLY	
401182	TempSetpoint	uint32	°F or °C	-40 to 118 (°F)	1 °	READ_ONLY	Temp Control must be set to On Above or On Below to use the setpoint

Modbus Register	Parameter Name	Data Type	Units	Range	Resolution	R/W Access	Notes
401184	TempControl	uint32	NA	0-3 0: = DISABLED 1: = DISPLAY 2: = ON BELOW 3: = ON ABOVE	NA	READ_WRITE	
401186	TempSetpoint	uint32	°F or °C	-40 to 118 (°F)	1 °	READ_WRITE	Only writes if $\geq -40$ & $\leq 118$ deg F Temp Control must be set to On Above or On Below to use the setpoint

# Technical Data

<b>Input Contact</b>	
Power Source (DC) - models B32627, B32629, B32631	9 - 26 VDC
Power Source (AC) - models B32628, B32630, B32632	100 VAC to 240 VAC - 50/60 Hz
Power consumption, max load (DC)	416 Watts
Power consumption, max load (120 VAC)	600 Watts
Power consumption, max load (240 VAC)	720 Watts
Cycle Control Pressure Input	Normally open cycle switch
Remote Disable (Auxiliary) Input	Configurable active high/low for normally open or normally closed switch
<b>Outputs</b>	
<b>Pump control</b>	Pump Control Voltage = Power Source
Voltage	Power Source
Max Switching Voltage (DC)	26 VDC
Max Switching Voltage (AC)	240 VAC
Max Switching Current (DC)	
Models B32627, B32629, B32631	25 A
Max Switching Current (AC)	
120 VAC	5 A
240 VAC	3 A
Minimum Switching Capacity	100 mA @ 5 VDC
<b>Enclosure Material</b>	Polycarbonate + PET
<b>Membrane Material</b>	Polyester
<b>Environmental</b>	
Protection Grade (Controller must be housed inside enclosure)	Type 1
Operating Temperature Range	- 40°F to 131°F (- 40°C to 55°C)
Storage Temperature	- 13°F to 131°F (- 25°C to 55°C)
<b>Duty Cycle</b>	
AC Models	100%
DC Models	90% (60 seconds typical)

# Graco Standard Warranty

Graco warrants all equipment referenced in this document which is manufactured by Graco and bearing its name to be free from defects in material and workmanship on the date of sale to the original purchaser for use. With the exception of any special, extended, or limited warranty published by Graco, Graco will, for a period of twelve months from the date of sale, repair or replace any part of the equipment determined by Graco to be defective. This warranty applies only when the equipment is installed, operated and maintained in accordance with Graco's written recommendations.

This warranty does not cover, and Graco shall not be liable for general wear and tear, or any malfunction, damage or wear caused by faulty installation, misapplication, abrasion, corrosion, inadequate or improper maintenance, negligence, accident, tampering, or substitution of non-Graco component parts. Nor shall Graco be liable for malfunction, damage or wear caused by the incompatibility of Graco equipment with structures, accessories, equipment or materials not supplied by Graco, or the improper design, manufacture, installation, operation or maintenance of structures, accessories, equipment or materials not supplied by Graco.

This warranty is conditioned upon the prepaid return of the equipment claimed to be defective to an authorized Graco distributor for verification of the claimed defect. If the claimed defect is verified, Graco will repair or replace free of charge any defective parts. The equipment will be returned to the original purchaser transportation prepaid. If inspection of the equipment does not disclose any defect in material or workmanship, repairs will be made at a reasonable charge, which charges may include the costs of parts, labor, and transportation.

**THIS WARRANTY IS EXCLUSIVE, AND IS IN LIEU OF ANY OTHER WARRANTIES, EXPRESS OR IMPLIED, INCLUDING BUT NOT LIMITED TO WARRANTY OF MERCHANTABILITY OR WARRANTY OF FITNESS FOR A PARTICULAR PURPOSE.**

Graco's sole obligation and buyer's sole remedy for any breach of warranty shall be as set forth above. The buyer agrees that no other remedy (including, but not limited to, incidental or consequential damages for lost profits, lost sales, injury to person or property, or any other incidental or consequential loss) shall be available. Any action for breach of warranty must be brought within two (2) years of the date of sale.

**GRACO MAKES NO WARRANTY, AND DISCLAIMS ALL IMPLIED WARRANTIES OF MERCHANTABILITY AND FITNESS FOR A PARTICULAR PURPOSE, IN CONNECTION WITH ACCESSORIES, EQUIPMENT, MATERIALS OR COMPONENTS SOLD BUT NOT MANUFACTURED BY GRACO.** These items sold, but not manufactured by Graco (such as electric motors, switches, hose, etc.), are subject to the warranty, if any, of their manufacturer. Graco will provide purchaser with reasonable assistance in making any claim for breach of these warranties.

In no event will Graco be liable for indirect, incidental, special or consequential damages resulting from Graco supplying equipment hereunder, or the furnishing, performance, or use of any products or other goods sold hereto, whether due to a breach of contract, breach of warranty, the negligence of Graco, or otherwise.

## **FOR GRACO CANADA CUSTOMERS**

The Parties acknowledge that they have required that the present document, as well as all documents, notices and legal proceedings entered into, given or instituted pursuant hereto or relating directly or indirectly hereto, be drawn up in English. Les parties reconnaissent avoir convenu que la rédaction du présente document sera en Anglais, ainsi que tous documents, avis et procédures judiciaires exécutés, donnés ou intentés, à la suite de ou en rapport, directement ou indirectement, avec les procédures concernées.

# Graco Information

For the latest information about Graco products, visit [www.graco.com](http://www.graco.com).

For patent information, see [www.graco.com/patents](http://www.graco.com/patents).

**TO PLACE AN ORDER**, contact your Graco distributor or call to identify the nearest distributor.

**Phone:** 612-623-6928 or **Toll Free:** 1-800-533-9655, **Fax:** 612-378-3590

*All written and visual data contained in this document reflects the latest product information available at the time of publication. Graco reserves the right to make changes at any time without notice.*

Original instructions. This manual contains English. MM 3A4130

**Graco Headquarters:** Minneapolis

**International Offices:** Belgium, China, Japan, Korea

**GRACO INC. AND SUBSIDIARIES • P.O. BOX 1441 • MINNEAPOLIS MN 55440-1441 • USA**  
**Copyright 2015, Graco Inc. All Graco manufacturing locations are registered to ISO 9001.**

[www.graco.com](http://www.graco.com)  
Revision G, 5/2019