

Parts



# GX19 Electric Airless Sprayer

3A4242A

EN ZH

***For professional use only.***

***Not approved for use in explosive atmospheres or hazardous locations.***

***For portable airless spraying of architectural paints and coatings.***

**Model: 17M853**

*3000 psi (207 bar, 20.7 MPa) Maximum Working Pressure.*

*User supplied spray gun and hose must be rated at a minimum of 3000 psi (207 bar, 20.7 MPa).*



## Important Safety Instructions

Read all warnings and instructions in this manual and related manuals. Be familiar with the controls and the proper usage of the equipment. Save these instructions.

### Related Manuals

**Operation 3A3212 English**

### 相关手册

**手术 3A3310 中文**

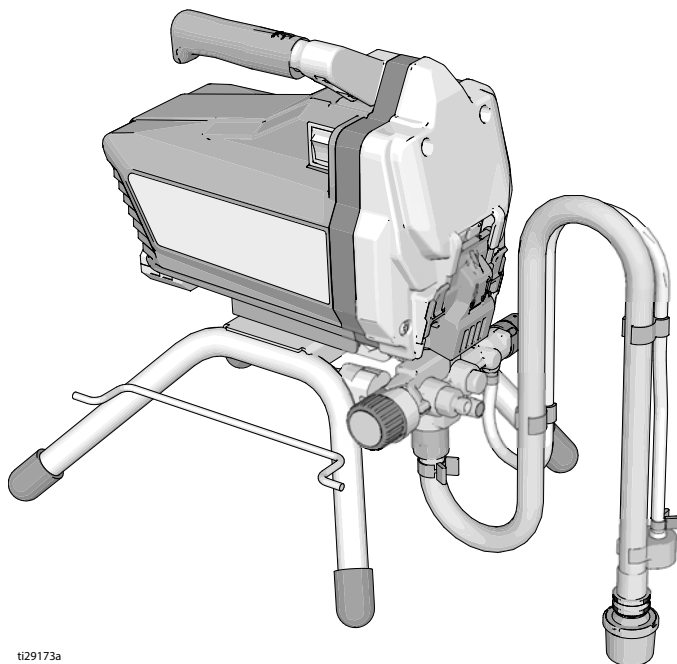

ti29173a

**PROVEN QUALITY. LEADING TECHNOLOGY.**

# GX19 电动无气喷涂机

## GX19 电动无气喷涂机

仅限专业人员使用。

不得用于爆炸性环境或危险场所。

用于建筑喷涂的轻便型无气喷涂机。

型号：GX17M853

3000 磅 / 平方英寸 (207 巴，20.7 兆帕) 最大工作压力。

用户提供的喷枪和软管必须至少 3000 磅 (207 巴，20.7 兆帕) 的额定





### 重要安全说明

请阅读本手册、相关手册和设备（包括电源线）上的所有警告及说明。熟悉该设备的控制装置和正确用法。妥善保存这些说明。



# 17M853 Stand Sprayer

## 17M853 Stand Sprayer

Ref.	Torque
 1	140-160 in-lb (16 - 18 N•m)
 2	30-35 in-lb (3.5 - 4.0 N•m)
 3	110-120 in-lb (12 - 14 N•m)

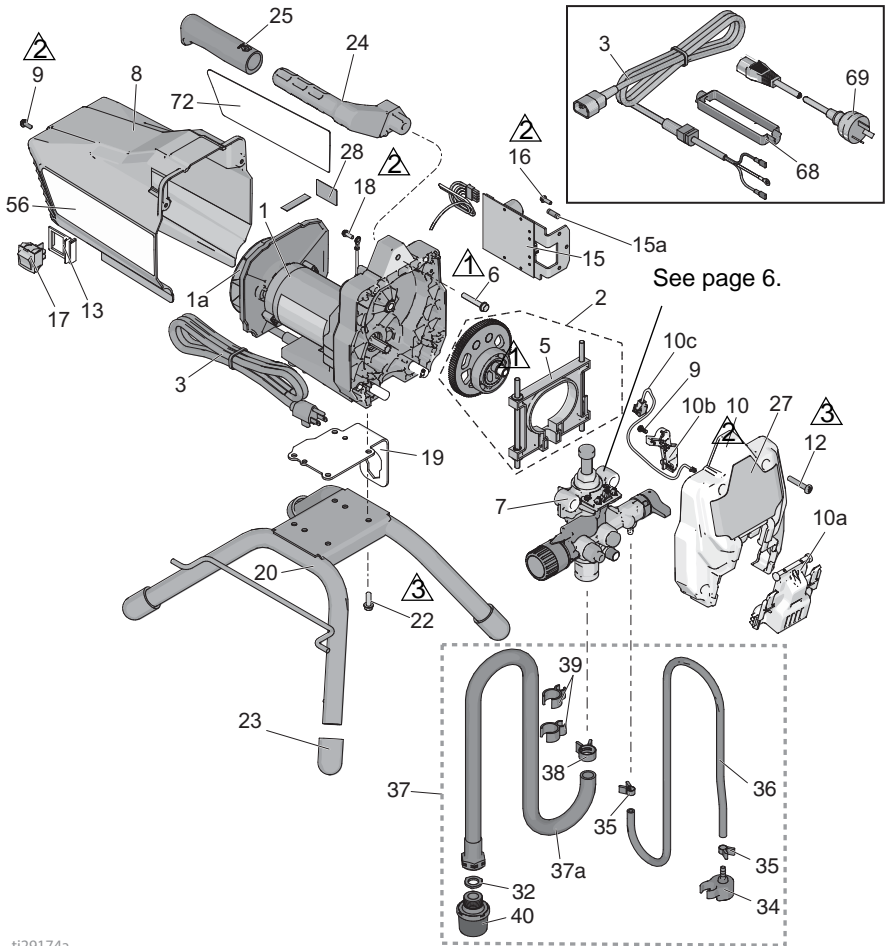

ti29174a





## 17M853 Stand Sprayers Parts List

Ref.	Part	Description	Qty.	Ref.	Part	Description	Qty.
1	17F758	KIT, motor, 230V <i>includes 1a</i>	1	19	17G329	PLATE, motor, mount	1
1a	16X980	KIT, fan, 230V	1	20	15E823	FRAME, standmount	1
2	17J863	KIT, gear and yoke <i>includes 5</i>	1	22	260212	SCREW, hwh, thread forming	4
3	17J405	CORD, power	1	23	15G857	CAP, leg	4
5	17J864	KIT, yoke	1	24	276864	HANDLE, sprayer	1
6	117493	SCREW, mach, hwhd	1	25	116139	GRIP, handle	1
7	17K842	PUMP, displacement	1	27	17J025	LABEL, front	1
8	17J865	SHIELD, motor <i>includes 9, 56</i>	1	32	115099	WASHER, hose	1
9	118444	SCREW, mach, hwhd 10-24 x 0.5 in.	3	34	244035	DEFLECTOR, barbed	1
10	17J866	KIT, cover, front <i>includes 9, 10a, 10b, 10c, 12</i>	1	35	115489	CLAMP, drain tube	2
10a	17F233	COVER, pump, locking	1	36	195084	TUBE, drain	1
10b	17F262	COVER, wire	1	37	17D156	TUBE, suction, assembly <i>includes 32, 34, 35, 36, 37a, 38, 39, 40</i>	1
10c	128551	CABLE, PC, jumper	1	37a	17D155	TUBE, suction <i>includes 32</i>	1
12	115478	SCREW, mach, Torx, pan hd	4	38	116295	CLAMP, tube	1
13	15X737	SWITCH, bracket	1	39	195400	CLIP, spring	2
15	17J885	KIT, control <i>includes 15a, 16</i>	1	40	288716	KIT, strainer	1
15a	119276	FUSE, 12.5A slow blow	1	56▲	17K017	LABEL, warning	1
16	117501	SCREW, plastite	1	57▲	17A134	CARD, medical alert (not shown)	1
17	118899	SWITCH, rocker	1	68	195551	RETAINER, plug	1
18	115498	SCREW, mach, slot, hex whd	1	69	242005	CORD SET, AU	1
				72	17J026	LABEL, side, GX 19	1

▲ Replacement Danger and Warning labels, tags, and cards are available at no cost.

# Pump Assembly Parts

## Pump Assembly Parts

Ref.	Torque	Ref.	Torque
 1	140-160 in-lb (16 - 18 N•m)	 4	220-250 in-lb (25 - 28 N•m)
 2	270-330 in-lb (30 - 37 N•m)	 5	320-380 in-lb (36 - 43 N•m)
 3	30-35 in-lb (3.5 - 4.0 N•m)		

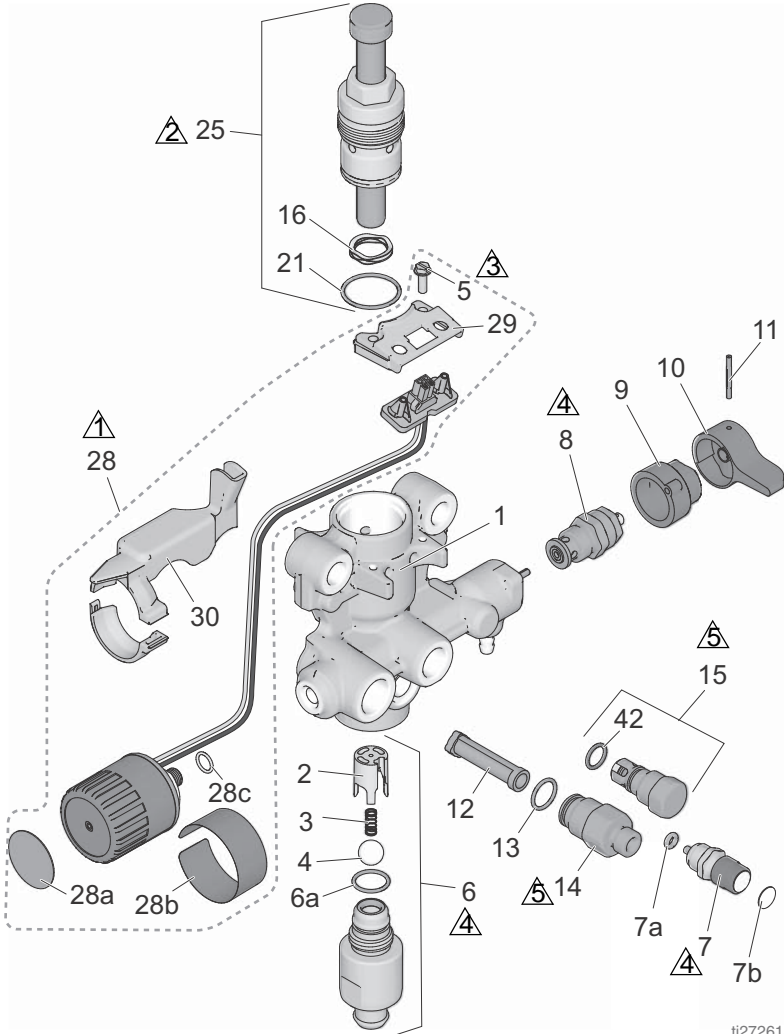

ti27261a

## Pump Parts List

Ref. Part	Description	Qty.	Ref. Part	Description	Qty.
1	17G447 HOUSING, pump	1	14	24Y327 KIT, repair outlet	1
2	17D364 GUIDE, ball	1		<i>includes 12, 13</i>	
3	128336 SPRING, compression	1	15	17J880 KIT, outlet valve repair	1
4	105445 BALL, 0.5 in.	1		<i>includes 42</i>	
5	117501 SCREW, mach, slot	2	16	128323 SPRING, valve	1
	HWH		21	16D531 PACKING, O-ring	1
6	17J876 KIT, inlet housing	1	25	24Y472 KIT, repair, piston pump	1
	<i>includes 2, 3, 4, 6a</i>			<i>includes 16, 21</i>	
6a	124582 PACKING, O-ring	1	28	17J881 KIT, pressure control	1
7	17J878 KIT, PushPrime	1		<i>includes 5, 28a, 28b,</i>	
	<i>includes 7a, 7b</i>			<i>29, 30</i>	
7a	16P303 PACKING, O-ring	1	28a	15A464 LABEL, control	1
7b	17K420 LABEL, PushPrime	1	28b	17C831 LABEL, control	1
8	235014 VALVE, drain, assy. 9,	1	28c	106555 O-ring	1
	<i>10, 11</i>		29	17F227 BRACKET, electrical	1
9	224807 BASE, valve <i>includes</i>	1		connector	
10	187625 HANDLE, valve, drain	1	30	17F229 KIT, shield, wire	1
11	111600 PIN, grooved	1	42	122486 PACKING, O-ring	1
12	288747 KIT, filter	1			
13	120776 PACKING, O-ring	1			

# Graco Information

For the latest information about Graco products, visit [www.graco.com](http://www.graco.com).

For patent information, see [www.graco.com/patents](http://www.graco.com/patents).

**TO PLACE AN ORDER**, contact your Graco distributor or call 1-800-690-2894 to identify the nearest distributor.

*All written and visual data contained in this document reflects the latest product information available at the time of publication.*

*The manufacturer reserves the right to make changes at any time without notice.*

Original Instructions. This manual contains English. MM 3A4242  
技术手册原文翻译。This manual contains Chinese. MM 3A4242

**GRACO INC. AND SUBSIDIARIES • P.O. BOX 1441 • MINNEAPOLIS MN 55440-1441 • USA**

**Copyright 2016, Graco Inc. All Graco manufacturing locations are registered to ISO 9001.**  
[www.graco.com](http://www.graco.com)

Revision A - July 2016