

Pulse[®] Metered Dispense Valve Oil Bar

3A5573C

EN

For fixed mounting of up to three Pulse metered dispense valves.

Not approved for use in explosive atmospheres or hazardous locations. For professional use only.

Model No.: 25D130 - Configures metered dispense valves for installation in the oil bar.

NOTE: One Model 25D130 is required for each model 24N415 metered dispense valve.

Maximum Working Pressure: 1500 psi (103 bar, 10 MPa)

Model No.: 25D121 - Oil Dispenser Bar



Important Safety Instructions

Read all warnings and instructions in this manual and all related Pulse system manuals. Save all instructions.

Related Manuals

3A5412 - Pulse Metered Dispense Valve

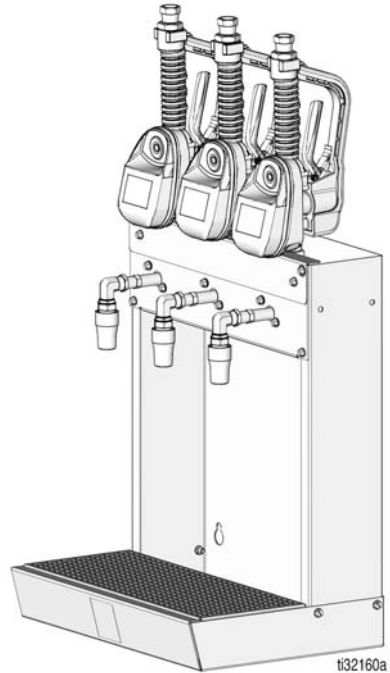

Refer to Parts, page 8 for reference numbers used in these instructions.

Installation

Prepare the Metered Dispense Valve for Installation

1. Secure the metered dispense valve in a vise (FIG. 1).
4. Install Graco identification label (7) over the existing GRACO identification label in the orientation shown in FIG. 4.

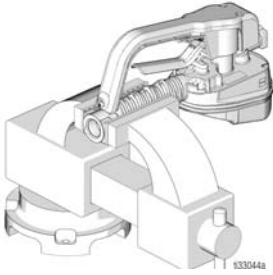

FIG. 1

2. Install strainer (9) and fitting (3) in the inlet (FIG. 2). Use wrench to tighten fitting.

NOTE: An o-ring is not required for the strainer (9) installation. An o-ring is required and installed on fitting (3).

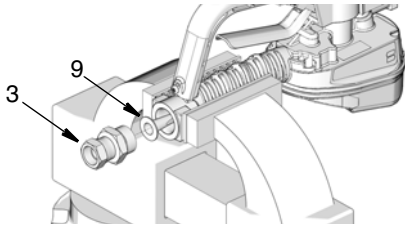

FIG. 2

3. Install fitting (1) in the outlet as shown in FIG. 3. Tighten fitting with a wrench.

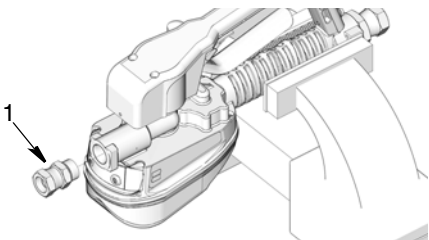

FIG. 3

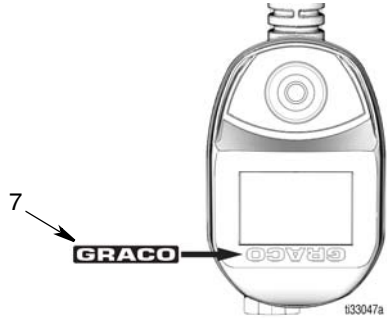

FIG. 4

5. Use the Utility Menu to flip the display for easy viewing when the metered dispense valve is installed in the Oil Bar. See the Pulse Metered Dispense Valve instruction manual for this procedure.

Assemble the Oil Bar

The oil bar requires assembly prior to use.

1. Attach dispenser wrapper (21) to drain pan (22) using screws (27), lock washers(28) and nuts (29) and existing holes. Tighten nuts securely. (See FIG. 5).

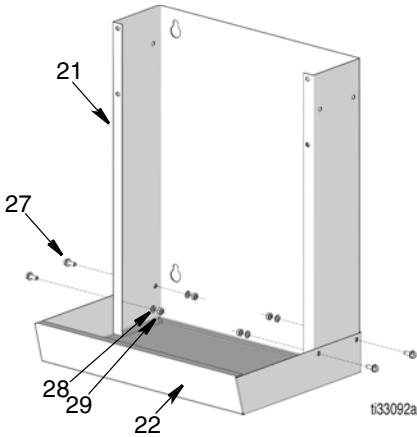

FIG. 5

2. Use the existing mounting holes in the back of the oil bar to secure it to a wall. Select a location that is easily accessible to the user and will adequately support the weight of the oil bar, metered dispense valves and plumbing.

NOTE: Fasteners for this installation are not included in the kit and must be provided by the user. When selecting fasteners consider the weight of the oil bar, metered dispense valves, plumbing fixtures and dispensed oil in the container placed on the shelf. See Technical Specifications, page 10.

3. Attach the meter mounting plate (24) to the wrapper dispenser (21) using screws (27), lock washers(28) and nuts (29) and existing holes. Tighten nuts securely. Refer to FIG. 6 for the correct installation orientation for these parts.

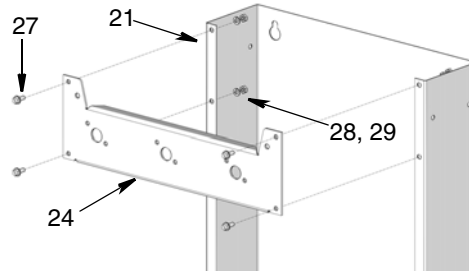

FIG. 6

4. Connect cover panel plate (25) to meter mounting plate (24) using screws (27) and existing holes. Tighten screws securely. Refer to FIG. 7 for the correct installation orientation for these parts.

NOTE: Do not assemble cover panel plate (25) prior to meter installation.

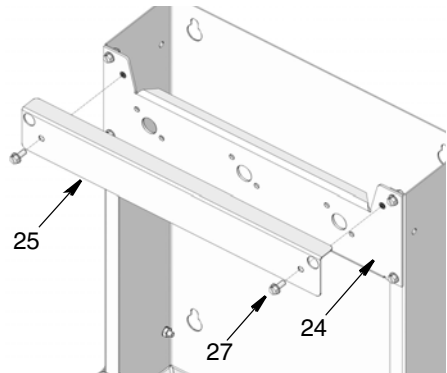

FIG. 7

5. Install pan strainer (23) in drain pan (22).

Installation

Install the Metered Dispense Valve in the Oil Bar

1. Wrap threads of pipe nipple (8) with PTFE tape or thread sealant as shown in FIG. 8. Install pipe nipple (8) in opening of manifold (2). Tighten securely. Refer to FIG. 8 to determine the correct installation position.

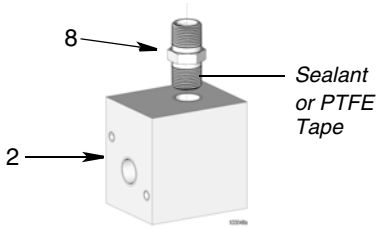

FIG. 8

2. **If installed when assembling the Oil Bar**, remove screws (27) and remove access panel (25).

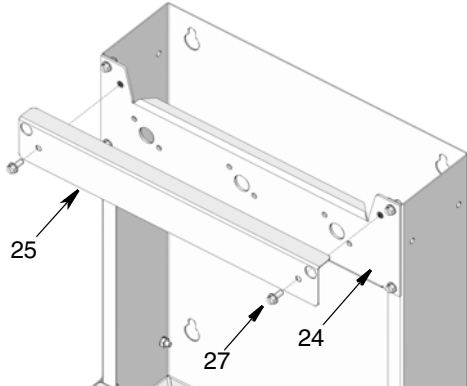

FIG. 9

3. Position manifold (2) inside oil bar, orienting opening (a) on the front of the manifold with opening (b) in the mounting plate (24) as shown in FIG. 10.

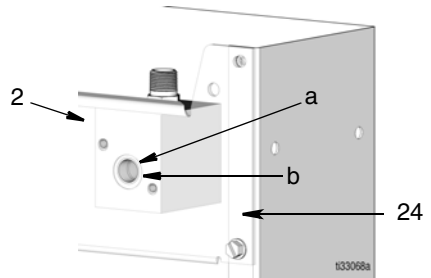

FIG. 10

4. Install screws (5) and washers (4) to hold the manifold (2) in place. Tighten securely.

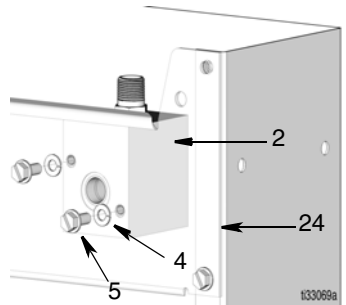

FIG. 11

5. Install the metered dispense valve in oil bar housing by connecting fitting (1) on metered dispense valve to pipe nipple (8) in manifold (2) as shown in FIG. 12. Tighten securely.

NOTE: Do NOT apply thread sealant or PTFE tape to threads of fitting (1).

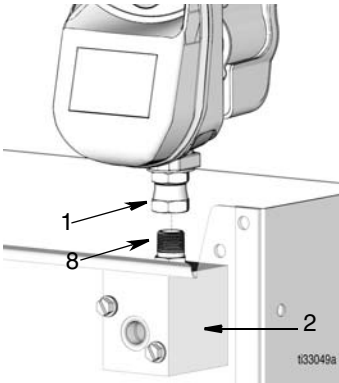

FIG. 12

6. Wrap threads on the long end of nipple adapter (10) with PTFE tape or thread sealant as shown in FIG. 13.

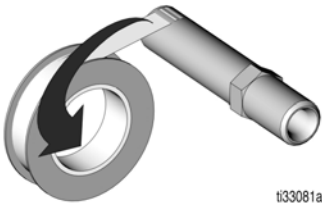

FIG. 13

7. Install the end of the nipple adapter (10) that was wrapped in the PTFE tape or treated with thread sealant into the manifold (2) through the hole (b) in the oil bar mounting plate (24).

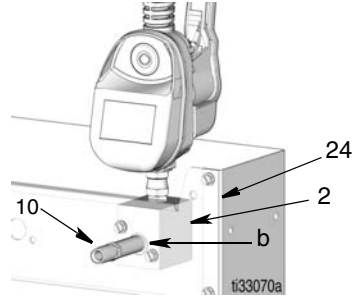

FIG. 14

8. Connect the swivel elbow (6) and high flow nozzle (11) to nipple adapter (10) in the orientation shown in FIG. 15. Tighten securely.

NOTE: Do NOT apply thread sealant or PTFE tape to threads.

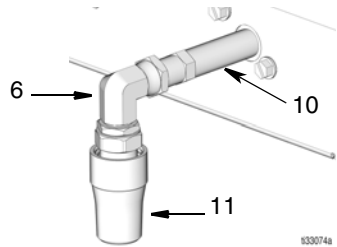

FIG. 15

9. Connect fluid distribution lines (c) to fitting (3).

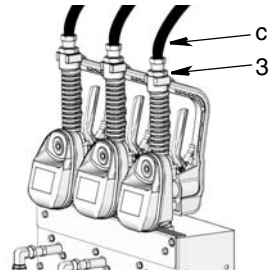

FIG. 16

Repair and Maintenance

Pressure Relief Procedure



PRESSURIZED FLUID HAZARD

This equipment stays pressurized until pressure is manually relieved. To help prevent serious injury from pressurized fluid, such as skin injection, splashing fluid and moving parts, follow the Pressure Relief Procedure when you stop dispensing and before cleaning, checking, or servicing the equipment.

PERSONAL PROTECTIVE EQUIPMENT

Wear appropriate protective equipment when in the work area to help prevent serious injury, including eye injury, hearing loss, inhalation of toxic fumes, and burns.

1. Turn off power supply to the pump.
2. Place a container under the drain valve on the oil bar (FIG. 18). Open the nozzle.
3. Pull trigger to dispense as much of the fluid as possible to relieve pressure.
4. Leave the nozzle open until you are ready to pressurize the system.

Oil Bar Disassembly

1. Relieve pressure. See the Pressure Relief Procedure.
2. Disconnect fluid distribution lines (c) from fitting (3) (see FIG. 17).

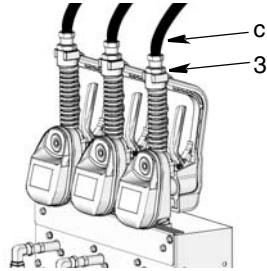

FIG. 17

3. Pull trigger to dispense as much of the fluid remaining in the line as possible (FIG. 18).

NOTE: A collection container should already be in place and the nozzle should be open after performing Pressure Relief Procedure (Step 1).

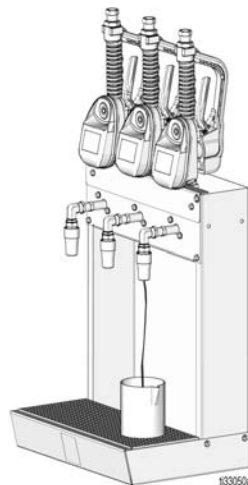

FIG. 18

4. Remove screws (27) and access panel (25) (see FIG. 19).

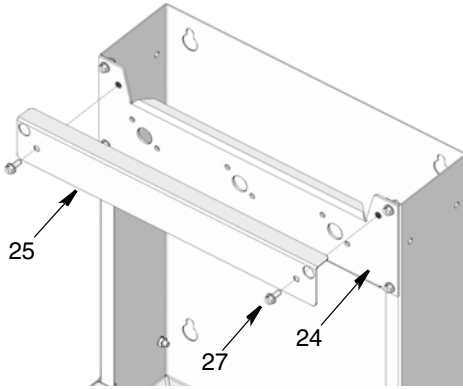

FIG. 19

5. Disconnect fitting (1) from pipe nipple (8) in manifold (2) as shown in FIG. 20.

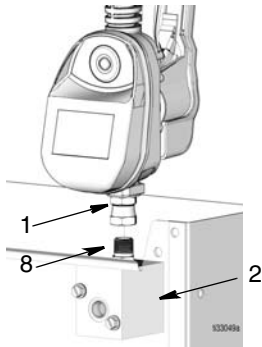

FIG. 20

6. Unscrew nipple adapter assembly (10, 6 and 11) from manifold (1).

NOTE: The nipple adapter (10), elbow (6) and swivel nozzle (11) do not have to be disassembled. These pieces can be removed from the manifold as a single assembly (FIG. 21).

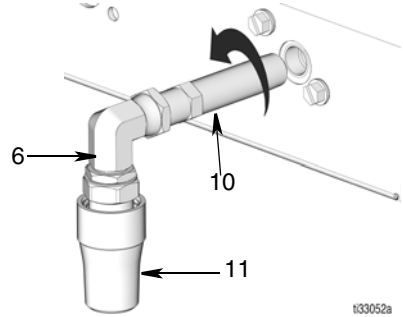

FIG. 21

7. Remove screws (5) and washers (4) from manifold (2). Lift manifold (2) straight up and out of the oil bar housing (FIG. 22).

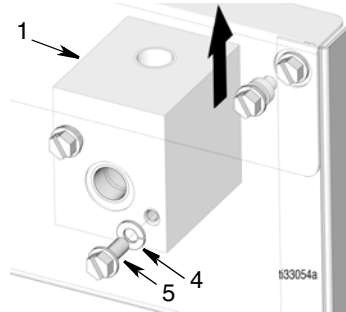

FIG. 22

8. To protect the metered dispense valve, lay it face down on a padded surface while performing any maintenance or service work on the metered dispense valve or oil bar.

Oil Bar Reassembly

To reassemble the oil bar, follow the **Installing Metered Dispense Valve in Oil Bar** instructions beginning on page 4.

Parts

Model 25D130

Ref	Part No.	Description	Qty
1	131244	FITTING, 3/4 ORB UNF X 3/8 NPSM	1
2	131245	MANIFOLD, dispenser	1
3	131246	FITTING, 1-1/16 ORB UNF X 1/2 NPSM	1
4	100016	WASHER, lock	2
5	108296	SCREW, hex	2
6	121079	SWIVEL, elbow, ORB X NPSM	1
7	130195	LABEL, brand, oil bar	1
8	156849	PIPE, nipple	1
9	15M308	STRAINER, wire mesh	1
10	160790	FITTING, nipple, adapter	1
11	255461	NOZZLE, high flow	1

Metered Dispense Valve 24N415 is shown for reference only. It must be ordered separately.

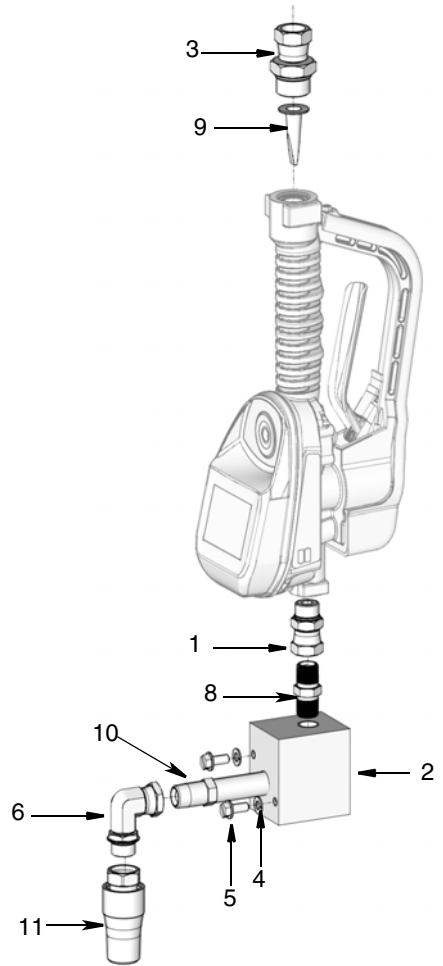

Model 25D121

Ref	Part No.	Description	Qty
21	181316	WRAPPER, dispenser	1
22	16D537	PAN, drain, coating	1
23	181319	STRAINER, pan	1
24	131242	PLATE, mount	1
25	131243	PLATE, cover panel	1
26	104663	PLUG, pipe	1

Ref	Part No.	Description	Qty
27*	108296	SCREW, hex	18
28*	100016	WASHER, lock	16
29*	100015	NUT, hex	16
30*	159346	WASHER	6

* Extra parts included for connecting multiple oil bars together.

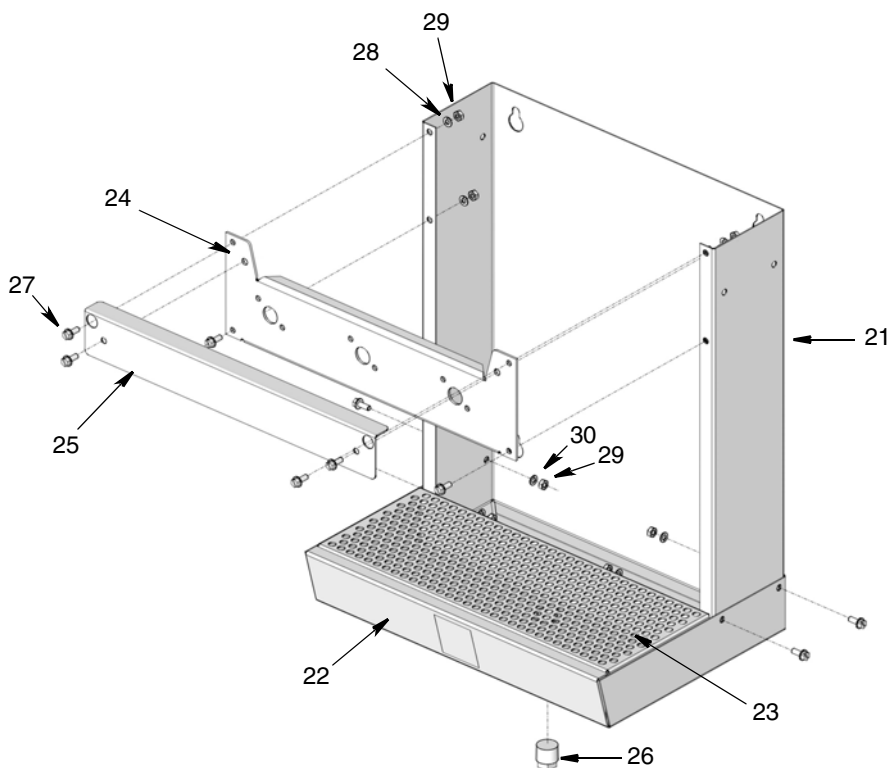

Technical Specifications

Technical Specifications

Oil Bar		
	US	Metric
Maximum Working Pressure	1500 psi	103 bar, 10 MPa
Wetted Materials	Carbon steel, aluminum, Buna-n rubber	
Weight		
Model 25D121	30 lbs	13.61 kg
Model 25D130	5 lbs	2.26 kg

Graco Standard Warranty

Graco warrants all equipment referenced in this document which is manufactured by Graco and bearing its name to be free from defects in material and workmanship on the date of sale to the original purchaser for use. With the exception of any special, extended, or limited warranty published by Graco, Graco will, for a period of twelve months from the date of sale, repair or replace any part of the equipment determined by Graco to be defective. This warranty applies only when the equipment is installed, operated and maintained in accordance with Graco's written recommendations.

This warranty does not cover, and Graco shall not be liable for general wear and tear, or any malfunction, damage or wear caused by faulty installation, misapplication, abrasion, corrosion, inadequate or improper maintenance, negligence, accident, tampering, or substitution of non-Graco component parts. Nor shall Graco be liable for malfunction, damage or wear caused by the incompatibility of Graco equipment with structures, accessories, equipment or materials not supplied by Graco, or the improper design, manufacture, installation, operation or maintenance of structures, accessories, equipment or materials not supplied by Graco.

This warranty is conditioned upon the prepaid return of the equipment claimed to be defective to an authorized Graco distributor for verification of the claimed defect. If the claimed defect is verified, Graco will repair or replace free of charge any defective parts. The equipment will be returned to the original purchaser transportation prepaid. If inspection of the equipment does not disclose any defect in material or workmanship, repairs will be made at a reasonable charge, which charges may include the costs of parts, labor, and transportation.

THIS WARRANTY IS EXCLUSIVE, AND IS IN LIEU OF ANY OTHER WARRANTIES, EXPRESS OR IMPLIED, INCLUDING BUT NOT LIMITED TO WARRANTY OF MERCHANTABILITY OR WARRANTY OF FITNESS FOR A PARTICULAR PURPOSE.

Graco's sole obligation and buyer's sole remedy for any breach of warranty shall be as set forth above. The buyer agrees that no other remedy (including, but not limited to, incidental or consequential damages for lost profits, lost sales, injury to person or property, or any other incidental or consequential loss) shall be available. Any action for breach of warranty must be brought within two (2) years of the date of sale.

GRACO MAKES NO WARRANTY, AND DISCLAIMS ALL IMPLIED WARRANTIES OF MERCHANTABILITY AND FITNESS FOR A PARTICULAR PURPOSE, IN CONNECTION WITH ACCESSORIES, EQUIPMENT, MATERIALS OR COMPONENTS SOLD BUT NOT MANUFACTURED BY GRACO. These items sold, but not manufactured by Graco (such as electric motors, switches, hose, etc.), are subject to the warranty, if any, of their manufacturer. Graco will provide purchaser with reasonable assistance in making any claim for breach of these warranties.

In no event will Graco be liable for indirect, incidental, special or consequential damages resulting from Graco supplying equipment hereunder, or the furnishing, performance, or use of any products or other goods sold hereto, whether due to a breach of contract, breach of warranty, the negligence of Graco, or otherwise.

FOR GRACO CANADA CUSTOMERS

The Parties acknowledge that they have required that the present document, as well as all documents, notices and legal proceedings entered into, given or instituted pursuant hereto or relating directly or indirectly hereto, be drawn up in English. Les parties reconnaissent avoir convenu que la rédaction du présente document sera en Anglais, ainsi que tous documents, avis et procédures judiciaires exécutés, donnés ou intentés, à la suite de ou en rapport, directement ou indirectement, avec les procédures concernées.

Graco Information

For the latest information about Graco products, visit www.graco.com.

For patent information, see www.graco.com/patents.

TO PLACE AN ORDER, contact your Graco distributor or call to identify the nearest distributor.

Phone: 612-623-6928 or Toll Free: 1-800-533-9655, Fax: 612-378-3590

All written and visual data contained in this document reflects the latest product information available at the time of publication.

Graco reserves the right to make changes at any time without notice.

Original instructions. This manual contains English. MM 3A5573

Graco Headquarters: Minneapolis

International Offices: Belgium, China, Japan, Korea

GRACO INC. AND SUBSIDIARIES • P.O. BOX 1441 • MINNEAPOLIS MN 55440-1441 • USA

Copyright 2018, Graco Inc. All Graco manufacturing locations are registered to ISO 9001.

www.graco.com

Revision, September 2019