

# PALMGREN®

## GENERAL PURPOSE ANGLE VISES

**MODELS:**  
**9611152**  
**9611253**  
**9611255**



*Read carefully and follow all safety rules and operating instructions before first use of this product.*

**DESCRIPTION**

Palmgren General Purpose Angle Vises are assembled in the U.S., and are constructed from fine grain cast iron with replaceable steel jaw plates. Lead screws on all models are precision cut V-thread. Palmgren General Purpose Angle Vises permit accurate positioning at any angle from horizontal to vertical. Model 9611255 comes with a 360° swivel base with a 5/8" keyway. Center of base is open for holding work through body of vise. Base and bed are parallel to 0.002" on all vises.

**SAFETY RULES**

- Understand and obey all safety instructions supplied with drill press, mill or other machines on which vise is used.
- Bolt or clamp vise to work surface in at least two mounting locations using mounting lugs on swivel base or angle base.
- Be sure workpiece is clamped securely between jaws before starting machining operation.
- Do not over tighten—vise can develop a large clamping force. Use only force which is needed.
- Do not pound or hammer on workpiece. This vise is designed to clamp the workpiece in a desired position for machining operations only.

Model	A	B	C	D	E	F	G	Weight
9611152	1-1/2"	2"	1-1/2"	1"	5-3/4"	7-1/2"	2-3/8"	4 lbs
9611253	2-7/16"	3-3/16"	2-1/2"	1-1/2"	7-1/2"	10-3/4"	3-7/8"	10 lbs
9611255	2-7/16"	3-1/8"	2-1/2"	1-1/2"	8"	11-1/2"	4-9/16"	14 lbs

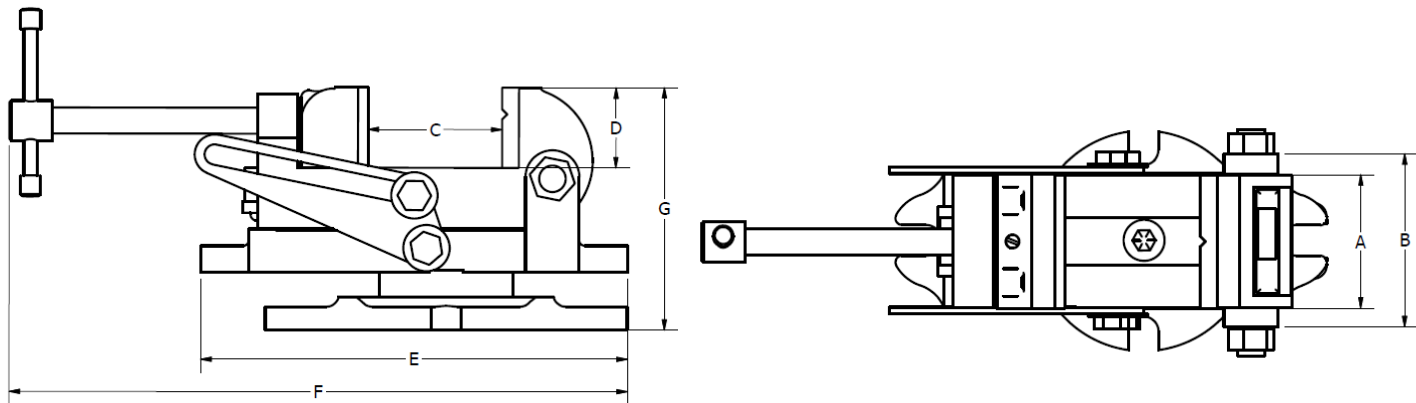

Figure 1 - Dimensions

**DIMENSIONS**

Refer to Figure 1.

**OPERATION**

Refer to Figure 2.

- Mount vise to work surface in desired location.
- Open jaws of vise and place workpiece between jaws in desired position. Secure workpiece between jaws by rotating leadscrew with handle (Ref. No. 3). Be sure workpiece is held securely in vise before starting machining operation.

**MAINTENANCE**

Particles of metal or wood can damage machined surfaces, causing difficult or inaccurate operation.

- The vise is shipped with a protective coating. This coating should be removed before operation. Use penetrating oil to remove protective coating.
- Keep machined surfaces and all moving parts clean and free of dirt, chips and foreign materials.
- Keep machined surfaces and lead screws lubricated with medium weight machine oil.

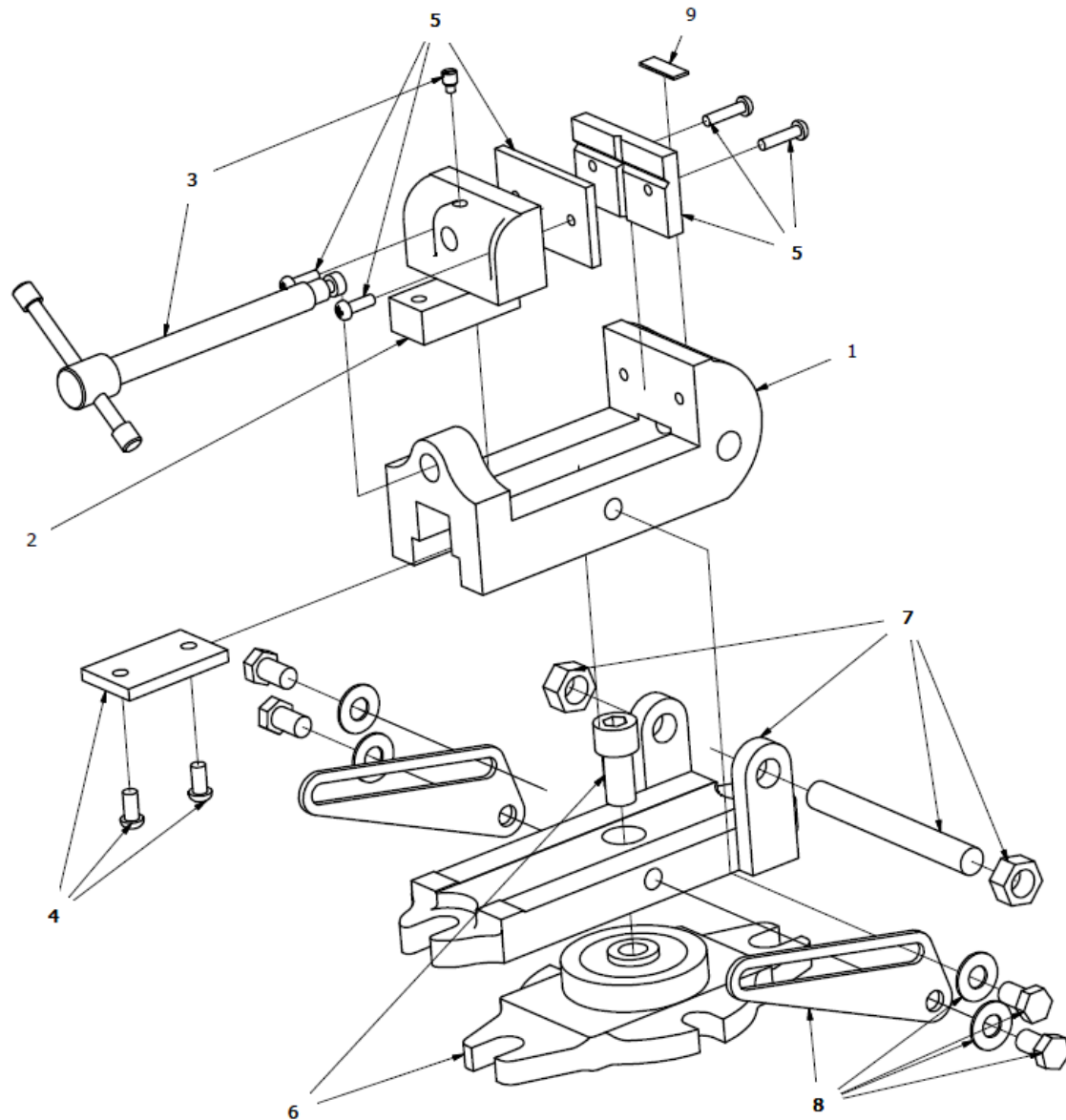

Figure 2 - Replacement Parts Illustration for General Purpose Angle Vises

**REPLACEMENT PARTS LIST FOR GENERAL PURPOSE ANGLE VISES**

Ref. No.	Description	Model 9611152	Model 9611253	Model 9611255
1	Body	N/A	N/A	N/A
2	Follower	N/A	N/A	N/A
3	Lead Screw Assembly	9610008.00	9610010.00	9610010.00
4	Bottom Plate Kit	9610024.00	9610025.00	9610025.00
5	Jaw Plate Kit	9610014.00	9610015.00	9610015.00
6	Swivel Base Kit	-	-	9610047.00
7	Angle Base Kit	9610101.10	9610201.10	9610201.10
8	Single Side Plate Kit	9610050.00	9610051.00	9610051.00
9	Palmgren Nameplate	N/A	N/A	N/A

(N/A) - Not available as a replacement part.

## WARRANTY

Palmgren warrants their products to be free of defects in material or workmanship. This warranty does not cover defects due directly or indirectly to misuse, abuse, normal wear and tear, failure to properly maintain the product, heated, ground or otherwise altered, or used for a purpose other than that for which it was intended. The warranty does not cover expendable and/or wear parts (i.e. v-belts, coated screws, abrasives), damage to tools arising from alteration, abuse or use other than their intended purpose, packing and freight. The duration of this warranty is expressly limited to the terms noted below beginning from the date of delivery to the original user. The Palmgren products carry the following warranties on parts with a 1 year warranty on labor:

- USA Machine vises – Lifetime
- IQ Machine vises – Lifetime
- Bench vises – Lifetime
- Positioning tables – Lifetime
- Bench grinders, buffers and belt grinders – 3 years
- Tapping machines – 3 years
- Drilling machines – 3 years
- Finishing machines – 3 years
- Band saws – 3 years
- Work stands – 3 years
- Arbor presses – 3 years
- Milling machines – 3 years
- Lathes – 3 years
- Accessories – 1 year

The obligation of Palmgren is limited solely to the repair or replacement, at our option, at its factory or authorized repair agent of any part that should prove deficient. Purchaser must lubricate and maintain the product under normal operating conditions at all times. Prior to operation become familiar with product and the included materials, i.e. warnings, cautions and manuals. **Failure to follow these instructions will void the warranty.**

This warranty is the purchaser's exclusive remedy against Palmgren for any deficiency in its products. Under no circumstances is Palmgren liable for any direct, indirect, incidental, special or consequential damages including lost profits in any way related to the use or inability to use our products. This warranty gives you specific legal rights which may vary from state to state.

### SERVICE & REPAIR

1. If a Palmgren product requires a repair or warranty service **DO NOT** return the product to the place of purchase.
2. All warranty related work must be evaluated and approved by Palmgren/C.H. Hanson.
3. Prior to returning any item the user must obtain factory approval and a valid RGA number.
4. For instructions and RGA number call toll free (800) 827-3398.