



SHOP-TAP TAPPING ARMS



Read carefully and follow all safety rules and operating instructions before first use of this product.

DESCRIPTION

Palmgren's Shop-Tap pneumatic tapping machine is a medium duty general purpose machine suitable for tapping small to medium size taps. The arm is equipped with lubricated for life bearings at all swivel points, provides weightless operation through the use of gas counter balance springs and permits the operator to bring the tap to the hole with ease.

UNPACKING

Check for shipping damage. If damage has occurred, a claim must be filed with the carrier immediately. Check for completeness. Immediately report any missing parts to dealer.

Refer to Figure 1.

Locate and account for the following components:

- A Base assembly
- B Filter, regulator & lubricator kit
- C Spindle motor
- D Air supply hose
- E Control arm

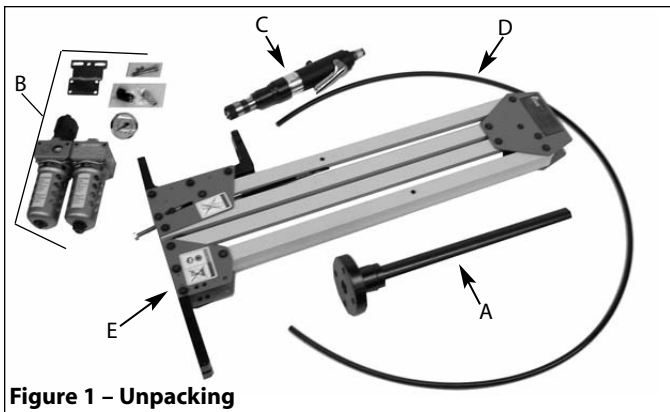

Figure 1 – Unpacking

SPECIFICATIONS

MODEL 80400

Spindle RPM.....	400
Torque @ 90PSI	27 Ft•lbs
Air consumption required	24 CFM
Max. tap size in steel	1/2" (12mm)
Max. tap size in aluminum.....	9/16" (14mm)
Quick change tool holder size	#1
Work area	20" to 57" radial distance from base
Weight.....	40 lbs.

MODEL 80401

Spindle RPM.....	700
Torque @ 90PSI	16 Ft•lbs
Air consumption required	24 CFM
Max. tap size in steel	3/8" (10mm)
Max. tap size in aluminum	1/2" (12mm)
Quick change tool holder size	#1
Work area	20" to 57" radial distance from base
Weight.....	40 lbs.

SAFETY RULES

WARNING: Some dust created by power sanding, sawing, grinding, drilling and other construction activities contains chemicals known to cause cancer, birth defects or other reproductive harm. Some examples of these chemicals are:

- Lead from lead-based paints.
- Crystalline silica from bricks and cement and other masonry products.
- Arsenic and chromium from chemically-treated lumber.

Your risk from these exposures vary, depending on how often you do this type of work. To reduce your exposure to these chemicals: work in a well ventilated area and work with approved safety equipment. Always wear **OSHA/NIOSH** approved, properly fitting face mask or respirator when using such tools.

WARNING: Always follow proper operating procedures as defined in this manual — even if you are familiar with use of this or similar tools. Remember that being careless for even a fraction of a second can result in severe personal injury.

BE PREPARED FOR JOB

- Wear proper apparel. Do not wear loose clothing, gloves, neckties, rings, bracelets or other jewelry which may get caught in moving parts of machine.
- Wear protective hair covering to contain long hair.
- Wear safety shoes with non-slip soles.
- Wear safety glasses complying with United States ANSI Z87.1. Everyday glasses have only impact resistant lenses. They are **NOT** safety glasses.
- Wear face mask or dust mask if operation is dusty.
- Always wear ear protection. The work area may include exposure to excessive noise levels which will require necessary ear protection.
- Be alert and think clearly. Never operate power tools when tired, intoxicated or when taking medications that cause drowsiness.

PREPARE WORK AREA FOR JOB

- Keep work area clean. Cluttered work areas invite accidents.
- Do not use power tools in dangerous environments. Do not use power tools in damp or wet locations. Do not expose power tools to rain.
- Work area should be properly lighted.
- Always be sure machine is anchored securely to the floor or bench.
- Keep visitors at a safe distance from work area.
- Keep children out of workplace. Make workshop childproof. Use padlocks, master switches and remove switch keys to prevent any unintentional use of power tools.

TOOL SHOULD BE MAINTAINED

- Always unplug tool prior to inspection.
- Consult manual for specific maintaining and adjusting procedures.
- Keep tool lubricated and clean for safest operation.
- Remove adjusting tools. Form habit of checking to see that adjusting tools are removed before switching machine on.
- Keep all parts in working order. Check to determine that the guard or other parts will operate properly and perform their intended function.

GENERAL SAFETY INFORMATION (CONTINUED)

- Check for damaged parts. Check for misalignment of moving parts, binding, breakage, mounting and any other condition that may affect a tool's operation.
- A guard or other damaged part should be properly repaired or replaced. Do not perform makeshift repairs. (Use parts list provided to order replacement parts.)
- Never brush away chips while the machine is in operation. All clean up should be done when the machine is stopped.
- Never modify machine without consulting manufacturer.
- Use sharp cutters and keep the tool clean for safest operation.

KNOW HOW TO USE TOOL

- Use right tool for job. Do not force tool or attachment to do a job for which it was not designed.
- Disconnect tool when performing maintenance.
- Avoid accidental start-up. Make sure that tool switch is in OFF position before connection to air supply.
- Do not force tool. It will work most efficiently at the rate for which it was designed.
- Leave hands free to operate machine. Protect hands from possible injury.
- Never leave a tool running unattended. Turn the power off and do not leave tool until it comes to a complete stop.
- Do not overreach. Keep proper footing and balance.
- Always avoid contact with coolant; guard the eyes, especially.
- All workpieces must be clamped to work table when using tapping machine. It is unsafe to use your hands to hold any work-piece.
- Keep hands away from moving parts.
- Know your tool. Learn the tool's operation, application and specific limitations.

CAUTION: Think safety! Safety is a combination of operator common sense and alertness at all times when tool is being used.

ASSEMBLY

Refer to Figures 2-11.

CAUTION: Do not attempt assembly if parts are missing. Use this manual to order replacement parts.

MOUNT BASE ASSEMBLY

Refer to Figure 2.

Mount base assembly to a solid horizontal surface using 3/8" or 10mm bolts (hardware not provided). Figure 2 shows the footprint of the base assembly.

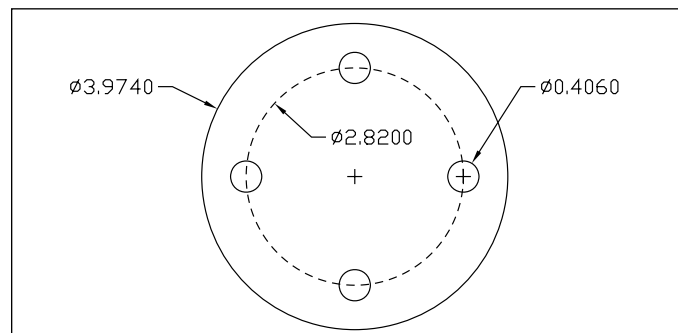

Figure 2 – Base Footprint (Dimensions in Inches)

ATTACH CONTROL ARM

Refer to Figure 3.

- Slide control arm over base assembly.
- Control arm height can be adjusted by position of the collar. Loosen set screw on collar, reposition to desired height and tighten set screw to secure in place.

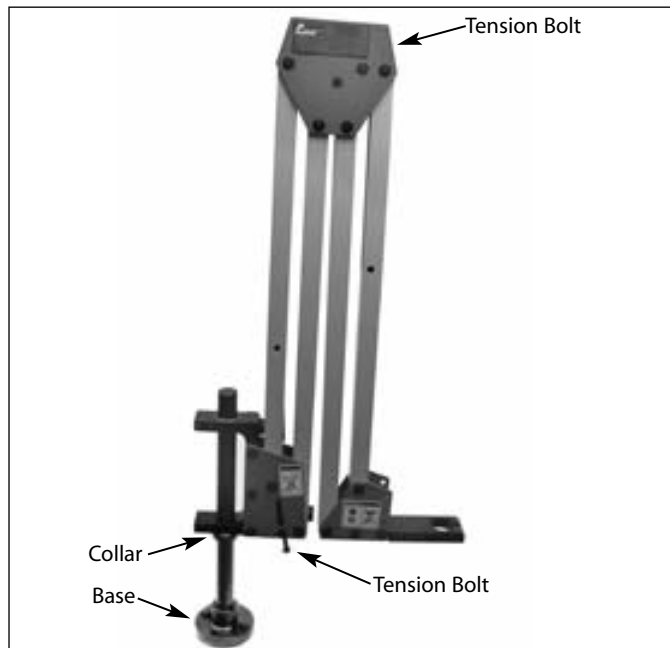

Figure 3 – Install Control Arm

ATTACH SPINDLE MOTOR

Refer to Figure 4.

- Insert spindle motor into bracket of control arm, make sure spindle is completely seated into the bracket.
- Secure spindle motor tightly into bracket using socket head bolt.

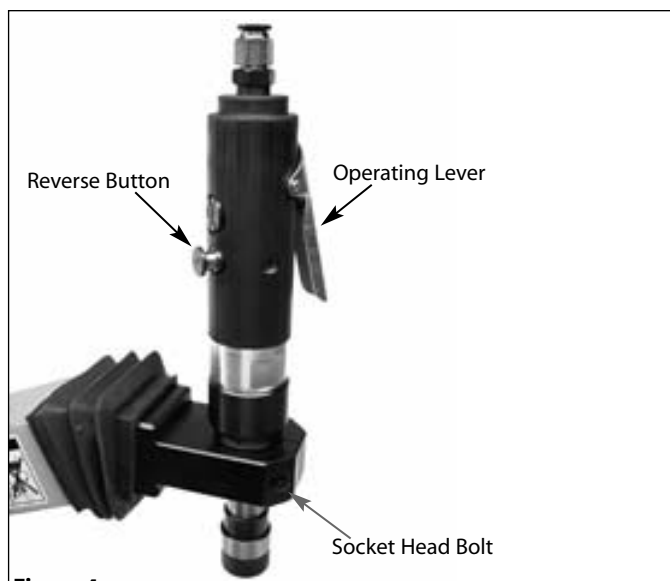

Figure 4

ASSEMBLY (CONTINUED)

MOUNT LUBRICATION UNIT

Refer to Figure 5.

- Remove front cover of lubricator body by lifting tab at top of cover and pulling cover outward.
- Insert the two mounting bolts as shown.

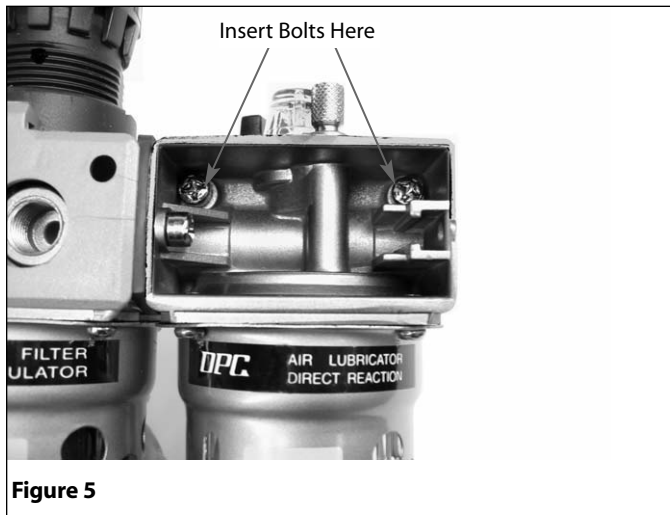

Figure 5

- Attach mounting bracket to the back of lubrication body with two nuts.
- Replace front cover.

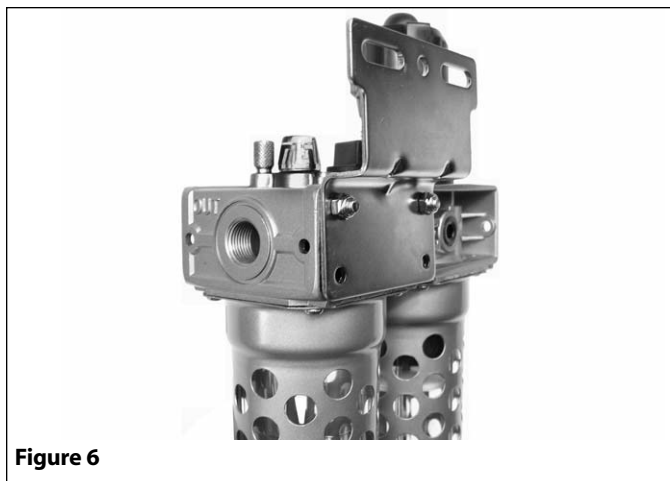

Figure 6

- Secure lubrication unit to the control arm bracket using socket head bolts provided. Attach bracket using the center hole and right slot of bracket.

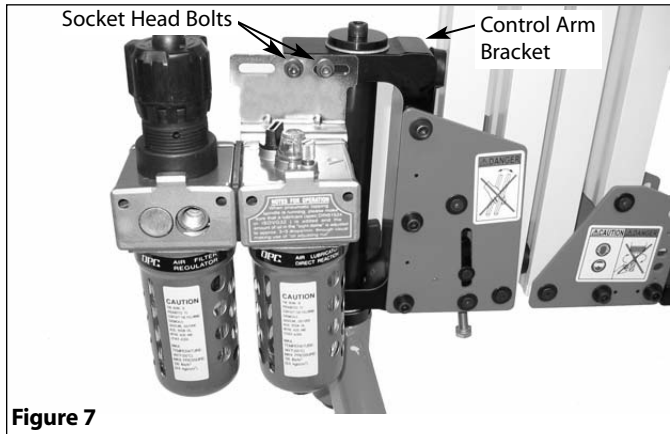

Figure 7

- Attach pressure gauge, quick connect and air hose fittings.

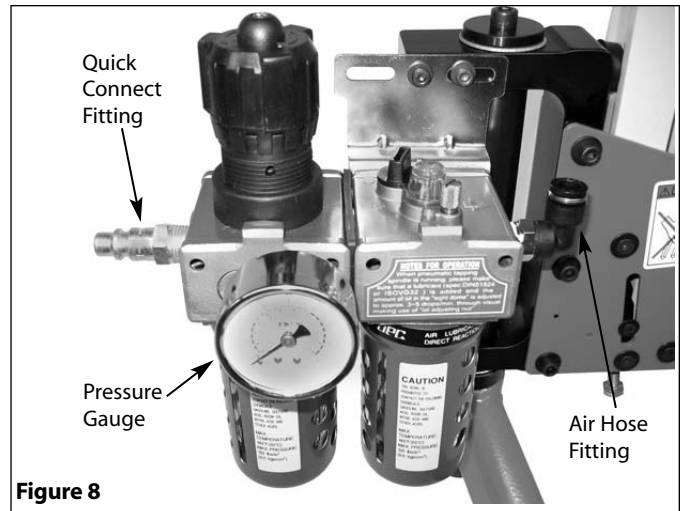

Figure 8

ATTACH AIR HOSE

Refer to Figure 9.

- Attach air hose into outlet fitting of lubrication unit, through clip at top of control arm, then into inlet fitting of spindle.
- Press hose firmly into fittings. Fittings are spring loaded. Hose can be removed by depressing lip of fitting.

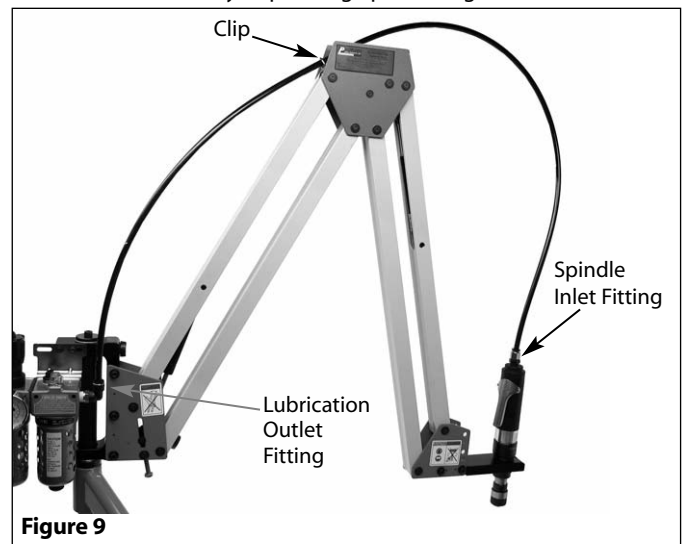

Figure 9

OPERATION

PREPARATION AND ADJUSTMENTS

Refer to Figures 10-12.

Caution: Add lubricant BEFORE connecting air supply to lubrication unit.

- Add lubricant (ISOVG32 or DIN51524 type oil) to the lubricator body. Unscrew the oil fill plug and add approximately 8-10 ounces of oil. Replace plug and tighten securely.
- Machine is supplied with a 3/8" quick connect. Connect air supply hose to quick connect. Models 80410 and 80411 require a minimum 5HP air compressor. Models 80412 and 80413 require a minimum 10HP air compressor.
- Pull the pressure adjusting knob up and adjust air pressure to 90 PSI (6 kgf/cm²). Rotate clockwise to increase pressure, counterclockwise to decrease pressure. If tapping 5/16" (8mm) or larger, adjust the air pressure to 115 PSI (8 kgf/cm²). After adjusting, press knob down to its locked position.

OPERATION (CONTINUED)

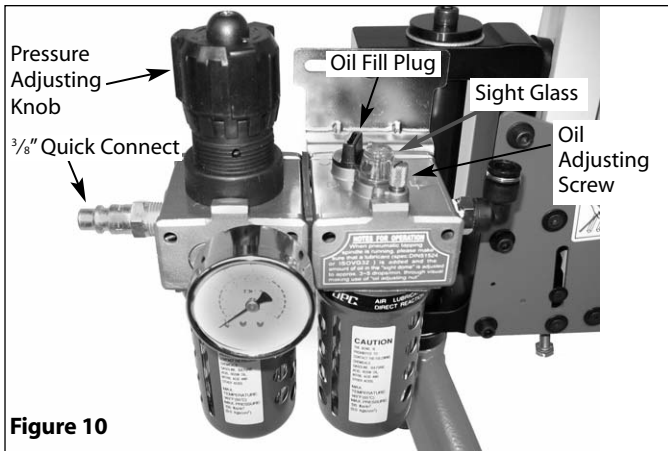

Figure 10

Caution: Do not exceed 135 PSI (9.5 kgf/cm²). This will cause bursting of the filter and lubricator bowls.

- Depress and hold the operating lever of the spindle. While the spindle is operating, check the oil flow rate through the sight glass on top of the lubricator body. The lubricator should operate at 3-5 drops/minute. Rotate the oil adjusting screw clockwise to decrease the oil flow rate; counterclockwise to increase the oil flow rate.
- Slide tap into tap holder (not included) until tap locks in place. Tap can be removed by simultaneously depressing flange and pulling out tap.

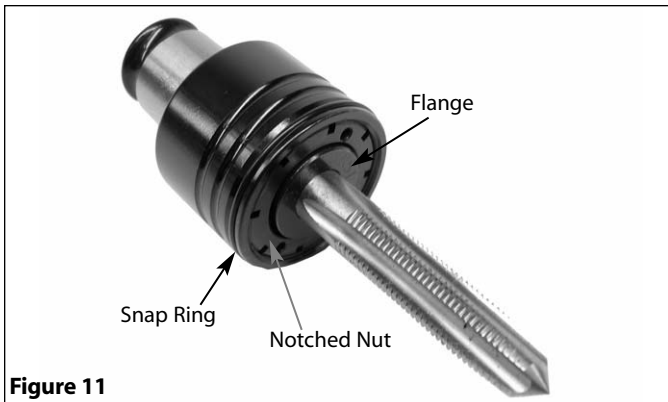

Figure 11

- Insert tap holder with tap into spindle. Pull up spindle chuck sleeve, insert tap holder with tabs aligned to slots in chuck sleeve, and then release sleeve.

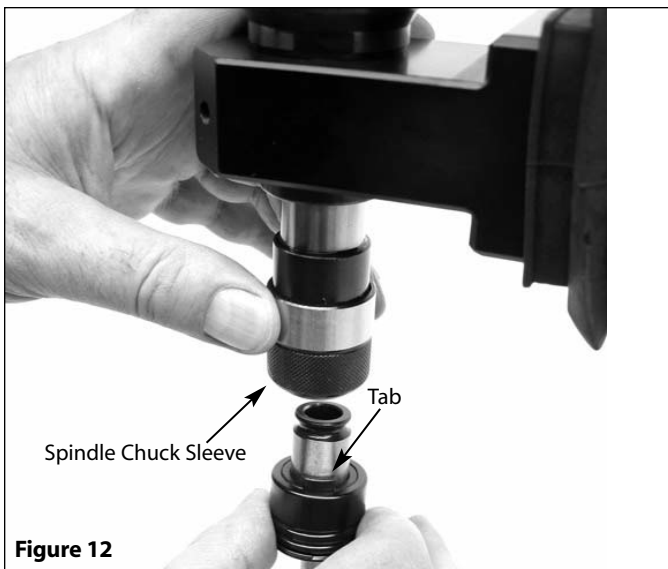

Figure 12

OPERATING PROCEDURE

Refer to Figures 4 and 11.

- Bring the spindle motor with tap to the hole to be tapped.
- Place the tip of the tap on the hole and depress the operating lever. The tap will self-center and begin cutting. Let the tap arm guide the tap into the hole.
- After tapping to the required depth, press the reverse button while also depressing the operating lever. The tap will reverse out from the hole.
- If the tap holder “clicks” or “ratchets”; the tap holder clutch torsion needs to be adjusted.

To adjust tap holder clutch (see Figure 11):

- Remove the spring clip from the groove of the tap holder.
- Turn the notched nut clockwise to increase torsion, counterclockwise to decrease torsion.
- Replace spring clip into the groove of the tap holder.
- Spindle motor speed can be adjusted by turning the screw above the reverse button (see Figures 4).
- Consult machinery reference books or your machine tool dealer for information concerning tap lubricant types, tapping speeds and tap types.

MAINTENANCE

WARNING: Make certain that unit is disconnected from air supply before attempting to service or remove any component.

- Keep machine and workshop clean. Keep mechanisms clean and free of foreign particles.
- Bearings located in arms are permanently lubricated and require no further lubrication

LUBRICATION UNIT

Refer to Figure 13.

- Always keep the lubricator oil reservoir full and make sure lubricator operates at 3-5 drops/minute.
- FILTER VALVE will open automatically and discharge when air pressure is less than 10 PSI (0.7 kgf/cm²). Filter valve can also be operated manually – discharge filter daily.
- LUBRICATOR RESERVOIR has manual drain.

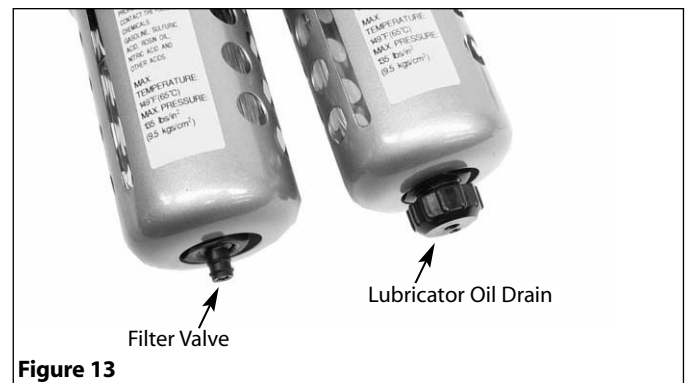

Figure 13

DAMPER SPRINGS

Refer to Figure 3.

- If the control arm moves stiffly or falls, the gas damper springs need adjustment or replacement. The tension bolts (see Figure 3) will increase tension when turned clockwise, and decrease when turned counter clockwise.

ACCESSORIES

- Contact your Palmgren distributor for tap holders, angle motor brackets and drill chuck attachments.

TROUBLESHOOTING

SYMPTOM	POSSIBLE CAUSE(S)	CORRECTIVE ACTION
Clutch slips and tap will not turn	<ol style="list-style-type: none"> 1. Tap holder clutch torsion needs to be adjusted 2. No tap lubrication 3. Dull tap 4. Hole and tap misaligned 5. Hole diameter too small 6. Wrong tap for workpiece material 	<ol style="list-style-type: none"> 1. Adjust tap holder clutch torsion (see Figure 14) 2. Apply lubrication to tap 3. Replace tap 4. Reposition tap arm 5. Enlarge hole 6. Replace tap
Spindle motor does not turn or stops	<ol style="list-style-type: none"> 1. Check air supply pressure 2. Excessive pressure drop (30 PSI) 3. Insufficient lubrication 4. Clogged spindle motor exhaust filter 5. Clogged air supply filter 6. Worn vanes 	<ol style="list-style-type: none"> 1. Adjust pressure between 90-115 PSI 2. Air supply compressor not large enough 3. Make sure oil flow rate from lubricator is 3-5 drops per minute 4. Clean or replace filter 5. Clean or replace filter 6. Replace vanes
Control arm drops or is difficult to move	Worn damper spring	Replace damper spring

Figure14 - Replacement Parts Illustration for Shop-Tap Tapping Arms

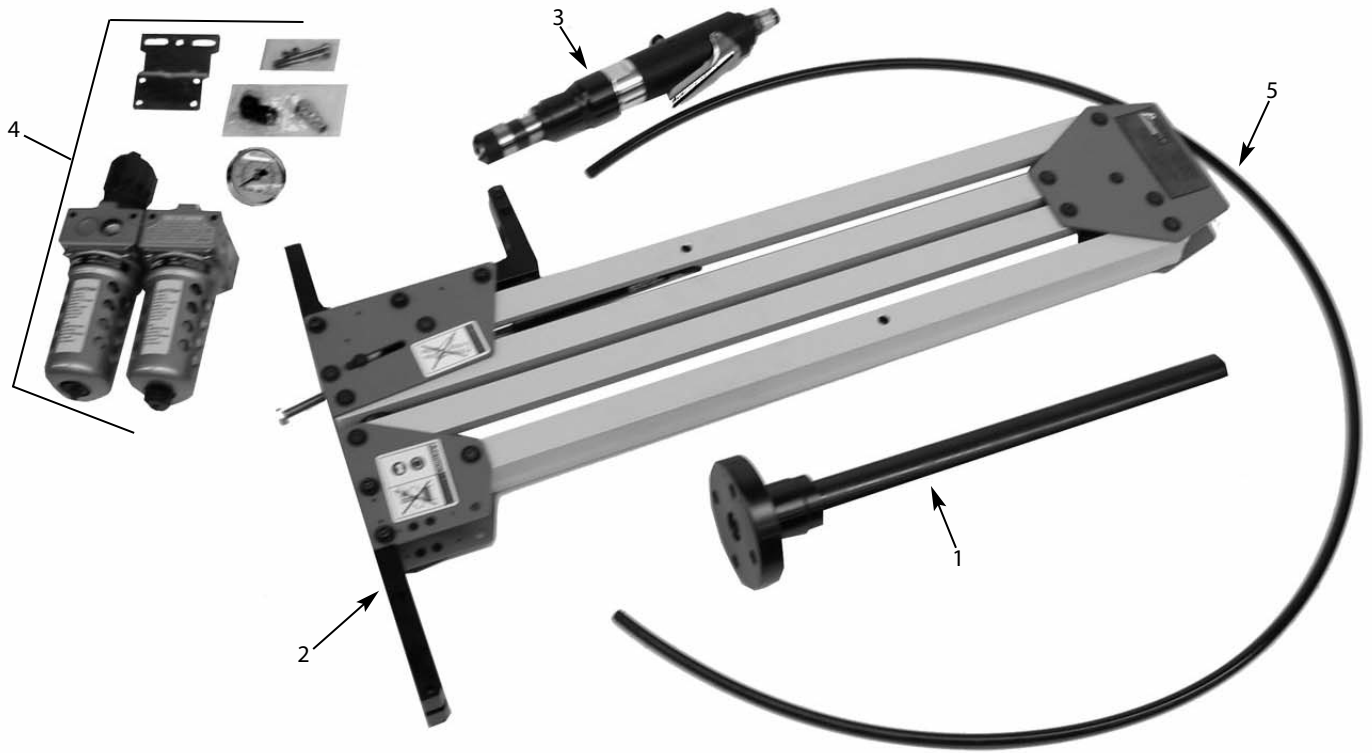

REPLACEMENT PARTS LIST FOR SHOP-TAP TAPPING ARMS

Ref. No.	Description	Part Number for:		Qty.
		80400	80401	
1	Base Assembly	26058.00	26058.00	1
2	Control Arm	26065.00	26065.00	1
Δ	Gas Spring	26070.00	26070.00	2
3	Spindle Motor	25997.00	25998.00	1
Δ	Rotor Vanes (set)	26004.00	26004.00	1
Δ	Exhaust Filter	26006.00	26006.00	1
Δ	Air Inlet Fitting	26007.00	26007.00	1
Δ	Trigger Assembly	26009.00	26009.00	1
4	Lubrication Unit	26011.00	26011.00	1
Δ	Pressure Gauge	26012.00	26012.00	1
Δ	Filter Bowl	26013.00	26013.00	1
Δ	Lubricator Bowl	26014.00	26014.00	1
Δ	Quick Change Fitting	25768.00	25768.00	1
Δ	Outlet Fitting	25958.00	25958.00	1
Δ	Air Filter	26015.00	26015.00	1
5	Air Hose	26068.00	26068.00	1
Δ	Operator's Manual	25771.09	25771.09	1

Δ Not Shown.

ONE YEAR LIMITED WARRANTY

Palmgren warrants to the original purchaser that all products covered under this warranty are free from defects in material and workmanship for a period of one year from the date of the original purchase.

We will repair or replace at our option, any part or parts of the product and accessories covered under this warranty which, after examination, proves to be defective in workmanship or material during the warranty period.

This warranty does not apply to repair or replacement required due to misuse, abuse, normal wear and tear, or repairs attempted or made by other than our Service Department or an Authorized Service Representative. Proper use and care instructions are provided in the operator's manual. Failure to follow these instructions will void the warranty.

This warranty gives you specific legal rights and you may also have other legal rights which may vary from state to state.

Responsibility of Original Purchaser (Initial User):

- To process warranty claim on this product, DO NOT return it to the retailer. The product must be evaluated by **Palmgren**. Call (800) 621-6145 for instructions.
- Retain original cash register sales receipt or invoice as proof of purchase for warranty work.
- Use reasonable care in the operation and maintenance of the product as described in the operator's manual.
- Deliver or ship the product(s) to **Palmgren**. Freight costs, if any must be paid by the purchaser.

This Warranty Does Not Cover:

- Merchandise sold as reconditioned, used as rental equipment, and floor or display models.
- Repair and transportation costs of merchandise determined not to be defective.
- Expendable parts or accessories supplied with the product which are expected to become inoperative or unusable after a reasonable period of use. See the operator's manual for a list of accessories and expendable parts.

