

LTR	REVISION DESCRIPTION	DATE	E.C.N.
A1	NEW RELEASE	1/21/04	8551
B1	ADDED (80K & D80K) TO DESCRIPTION	4/30/04	8623
C1	ADDED FOUR SLOTS FOR DP REELS	2/13/08	11006
D1	ADDED CR6 NOTE	7/13/15	17075SUP17
E1	REMOVED PURCHASED FROM	10/26/15	17296

DRAWING NO. 600980

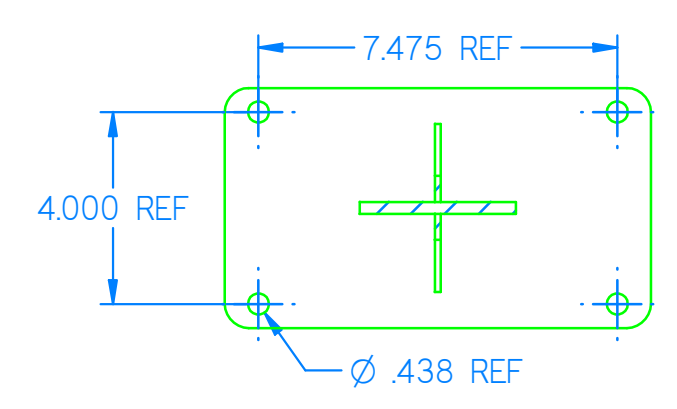
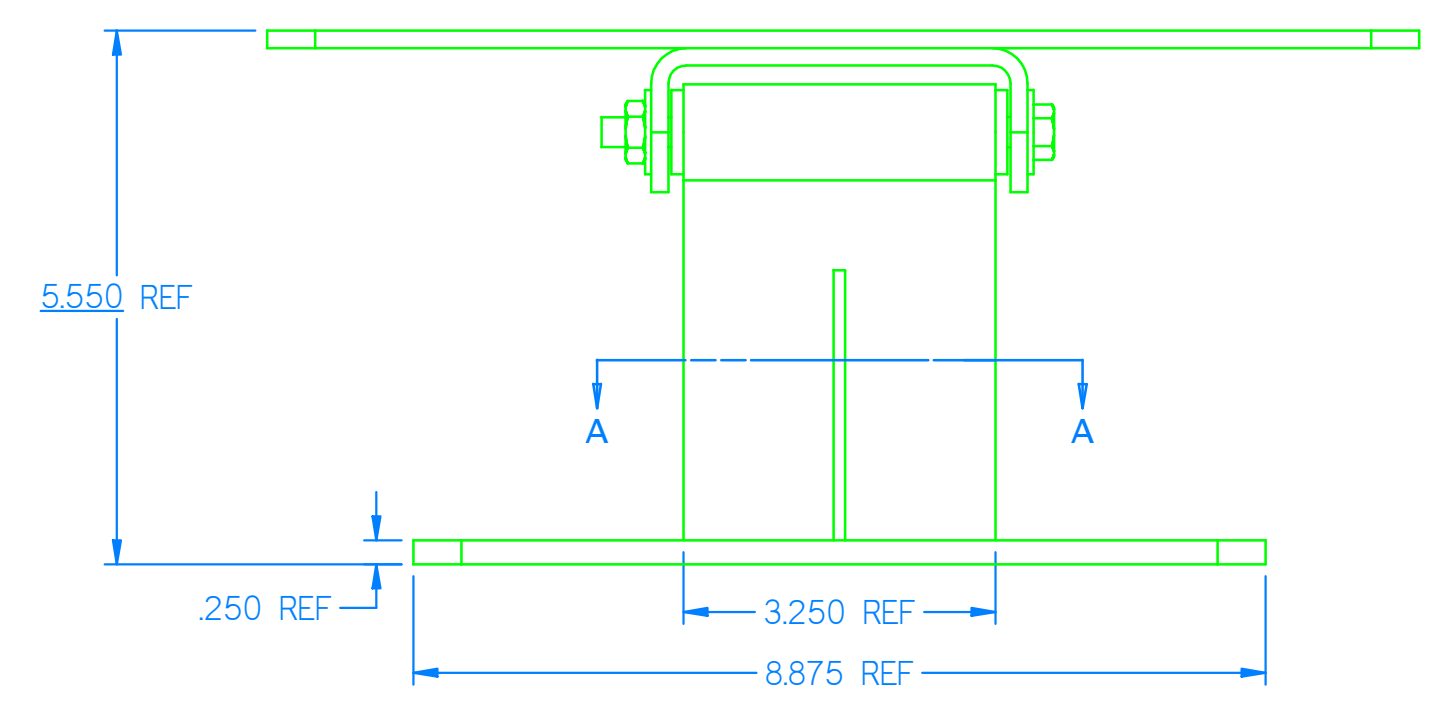
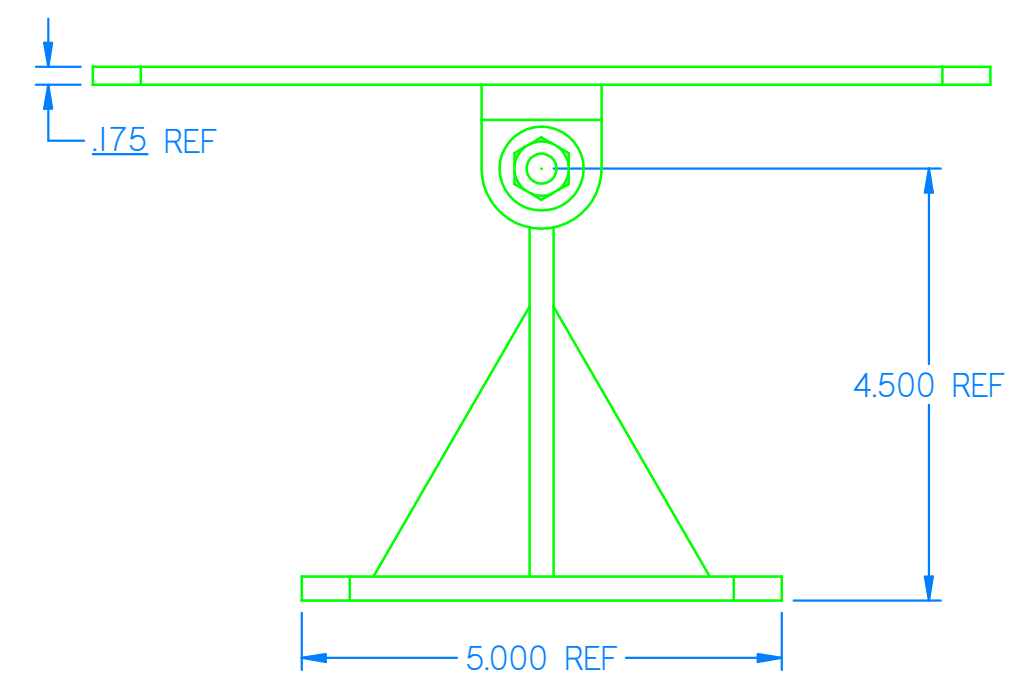
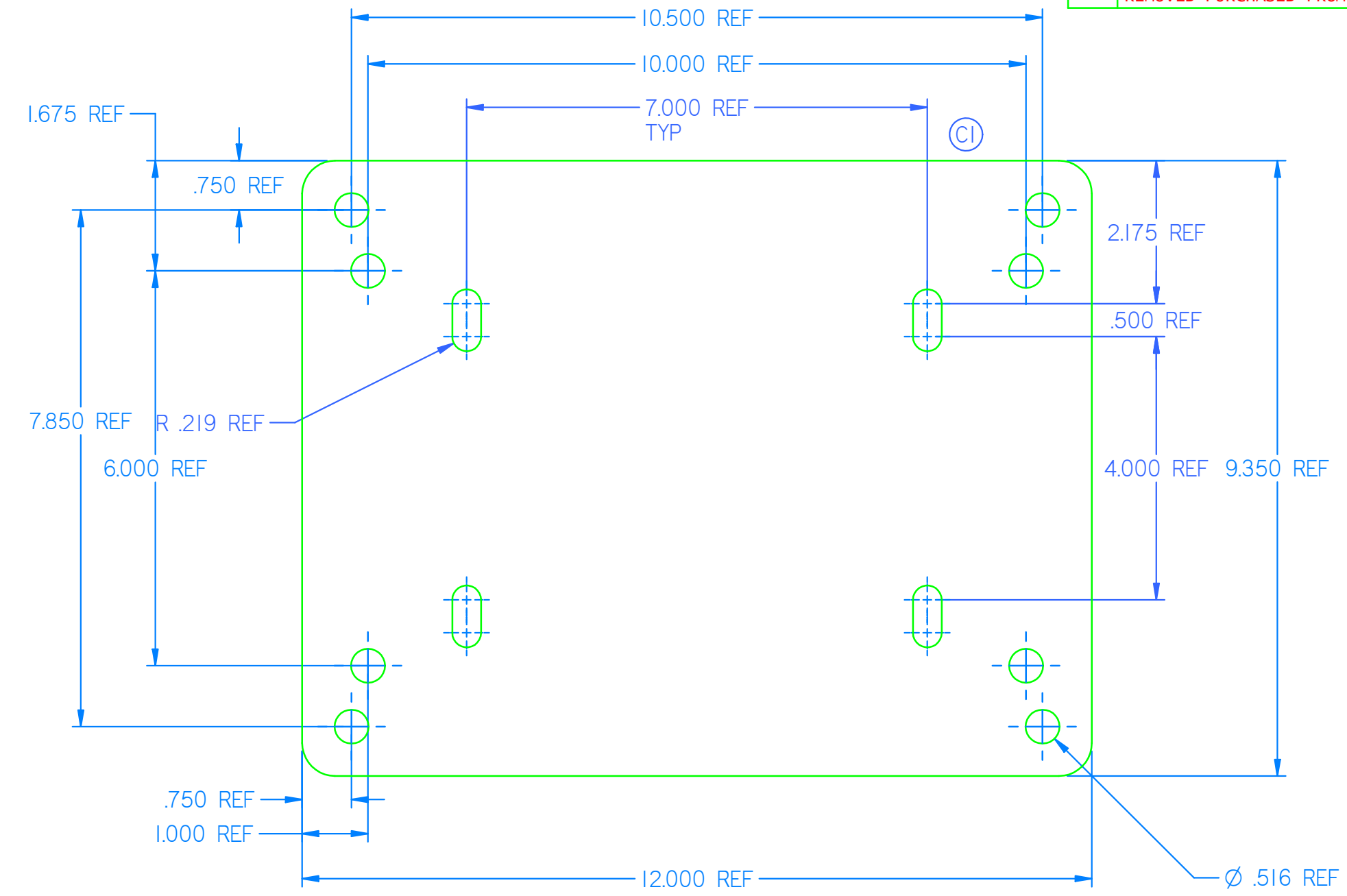
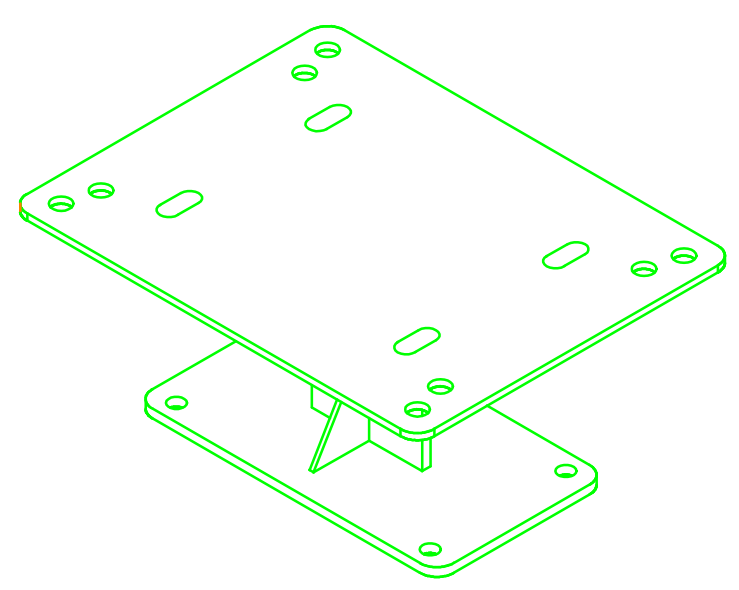

SECTION A-A
MOUNTING VIEW
(1:4 SCALE)

NOTE: (E1)
 - REELCRAFT WILL SUPPLY CARTON LABELS WITH ORDERS INCLUDED BUT NOT SHOWN:
 - (1) REQ'D BAGGED MOUNTING HARDWARE

(D1) THE PRODUCT SHALL NOT CONTAIN HEXAVALENT CHROMIUM IN CONCENTRATIONS ABOVE 0.1% W/W ON EACH HOMOGENOUS MATERIAL

MATERIAL AS PURCHASED	UNLESS OTHERWISE NOTED: DIMENSIONS ARE INCHES. TOL.-ANGLES±2° CONC..010T.I.R. FRACTIONS REF. TO IND. STDS. REMOVE BURRS, BREAK SHARP CORNERS NOT TO EXCEED .015 MACH. SURFACES ARE $\sqrt{125}$ MAX	REELCRAFT REELCRAFT INDUSTRIES INC. COLUMBIA CITY, IN 46725 U.S.A.	80000 D80000
FINISH BLACK	DRAWN BY JTF 1/21/04	DRAWING TITLE WALL MOUNTED SWING BRACKET (B1) (80000 & D80000)	NEXT ASS'Y USED ON
HEAT TREAT NONE	CHECKED BY	THIS MATERIAL IS OWNED BY REELCRAFT INDUSTRIES INC. AND IS NOT TO BE REPRODUCED OR DISTRIBUTED WITHOUT WRITTEN PERMISSION	EXP. NO. RE6550
WEIGHT 11.5 LB	ENG. APPROVAL ELW MFG. APPROVAL WPS SCALE 1/2 C	600980	DRAWING NO.

SIMILAR TO: 600626