

# Guillotine Pipe Cutter

Model 1697

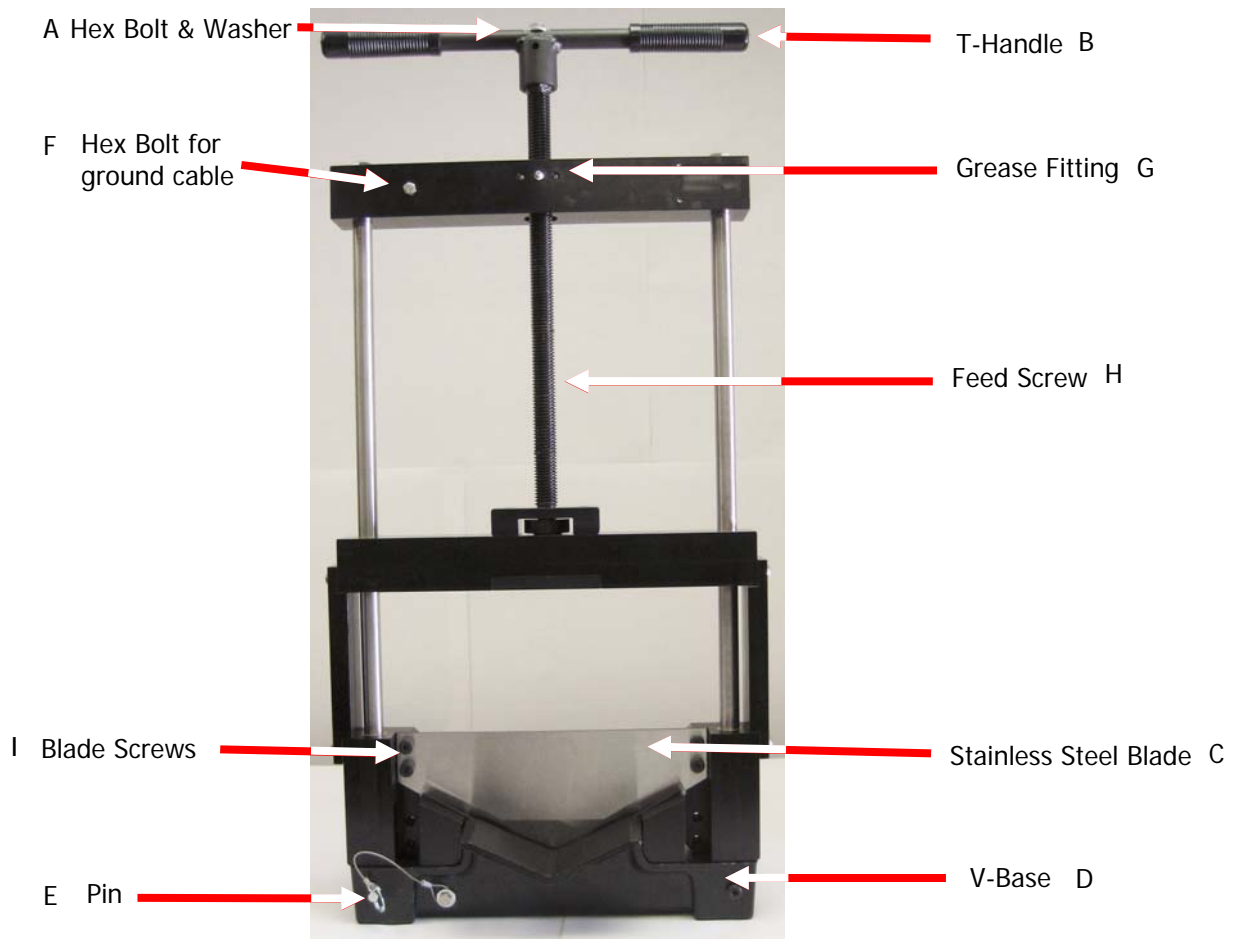

## For cutting 8" diameter (225mm) SDR11 pipes

Removable T-Handle design, which when removed exposes a 1" hex nut. This nut can also be driven with a ratchet and 1" socket.

A Hex Bolt and washer

E Pin

B T-Handle

F Hex Bolt for Ground Cable

C Stainless Steel Blade

G Grease Fitting

D V-Base

H Feed Screw

I Blade Screws

# Guillotine Pipe Cutter

Model 1697

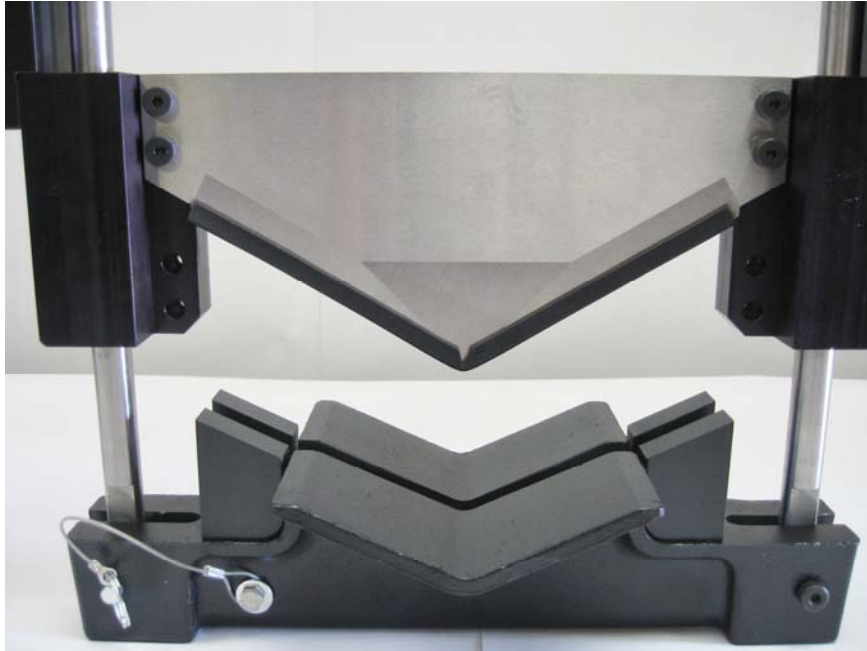

While wearing gloves, remove rubber guard before cutting pipe.

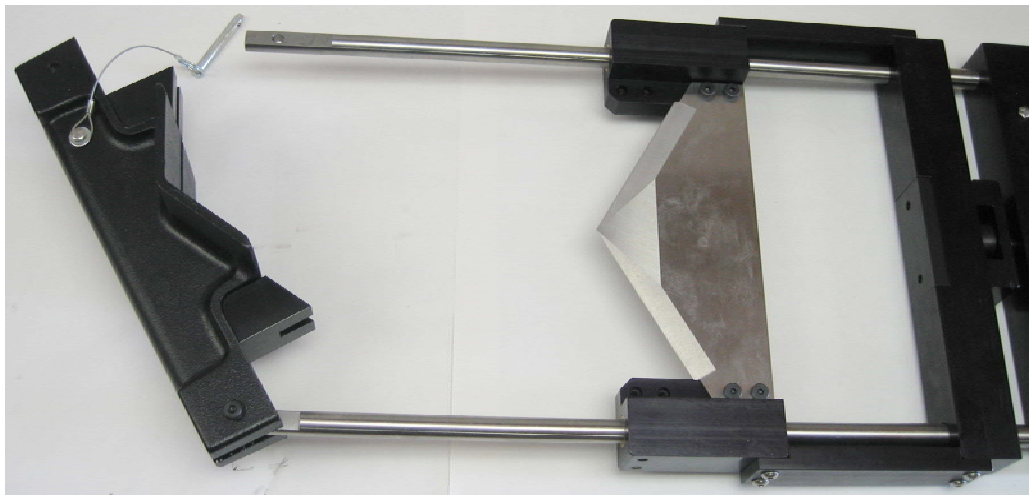

Turn handle and open blade all the way. Pull pin to allow bottom of V-Base to swing out. Place cutter over pipe. Swing V-Base back and replace pin.

# Guillotine Pipe Cutter

Model 1697

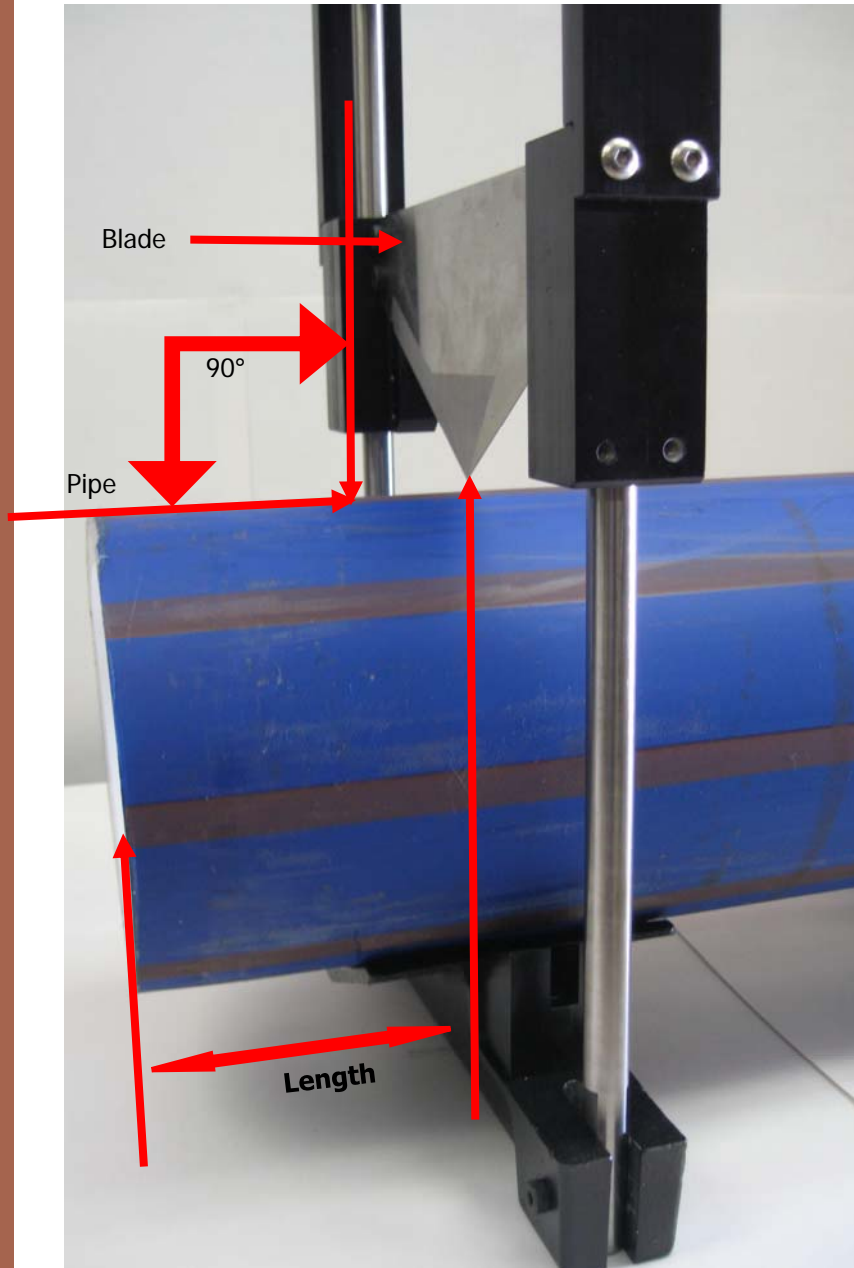

Make sure pipe is properly placed in V-Base. Blade must be perpendicular to the pipe before a cut can begin.

Length = Pipe Diameter

Minimum suggested cut length is the pipe diameter.

Example:

8" OD pipe

Minimum cut length is 8" long

# Guillotine Pipe Cutter

Model 1697

---



Make sure feed screw is kept greased and free of dirt. If dirty, wipe clean and reapply grease per instructions below.

Open blade all the way. Add 2 to 3 pumps of grease prior to use. Grease will collect in pocket under threaded bushing. As you close the blade, grease will be applied to the feed screw. Approximately 1/2 way down, add 2 to 3 more pumps of grease. Then continue to close the blade. Open blade all the way and you are now ready to cut pipe.

Sharpening the blade (or replacing the blade):

- 1) Open the cutter so the entire blade is visible.
  - 2) Remove four (4) blade screws (I), then use Wheeler Rex Model 7325 Blade Sharpener to sharpen the blade. Always wear gloves. Do not use a hand held grinder to sharpen blades!
-

# Guillotine Pipe Cutter

Model 1697

## WARNING

### GENERAL TOOL OPERATION WARNINGS

#### FOR ALL TOOLS-

1. **Keep Guards in Place** and in working order.
2. **Remove Adjusting Keys and Wrenches** from tool before turning it on.
3. **Keep Work Area Clean.** Cluttered areas and benches invite accidents.
4. **Avoid Dangerous Environment.** Don't use power tools in damp or wet locations. Keep work area well lit. Don't expose power tools to rain.
5. **If you must use an electric tool** in a damp or wet location; make sure it is plugged into a circuit which is protected by a ground fault interrupt.
6. **Keep Children Away. ALL VISITORS SHOULD BE KEPT A SAFE DISTANCE FROM WORK AREA.**
7. **Store Idle Tools** in dry, high, or locked-up place out of reach of children.
8. **Don't Force Tool.** It will do a better and safer job at the rate for which it is designed.
9. **Use Right Tool.** Don't force a small tool or attachment to do the job of a heavy-duty tool.
10. **Wear Proper Apparel.** No loose clothing or jewelry to get caught in moving parts. Rubber gloves and footwear are recommended when working outdoors.
11. **Use Safety Glasses.**
12. **Don't Abuse Cord.** Never carry tool by cord or yank it to disconnect from receptacle. Keep cord from heat, oil, and sharp edges.
13. **Secure Work.** Use clamps or vise to hold work when practical. It's safer than using your hand and it frees both hands to operate tool.
14. **Don't Overreach.** Keep proper footing and balance at all times.
15. **Maintain Tools Properly.** Keep tools sharp and clean for best and safest performance. Follow instructions for lubricating and changing accessories. Equipment operators must have proper maintenance & instruction sheets. Be sure the tool operator reads and understands this information. If you don't have current maintenance and instruction sheets, contact the factory & we will supply them at no charge.
16. **Disconnect Tools** when not in use; before servicing; when changing accessories such as dies, cutters, etc.
17. **Avoid Accidental Starting.** Don't carry plugged-in tool with finger on switch. Be sure switch is off when plugging in.
18. **Outdoor Use Extension Cords.** When tool is used outdoors, use only extension cords suitable for use outdoors and so marked.
19. **Wear Ear Protection** if exposed to long periods of very noisy shop operations.
20. **Do not operate tools** while under the influence of alcohol, drugs or medication.



PIPE TOOLS

## WHEELER-REX LIMITED LIFETIME WARRANTY

WHEELER-REX covers its products with a Limited Lifetime Warranty, with exception of pipe threading machines which have a Limited Three Year Warranty (including electric motors). Warranties from manufacturers of components used in our products may pre-empt the Wheeler-Rex warranty. Wheeler-Rex warrants against defects in material or workmanship. To take advantage of this warranty, the complete product must be delivered prepaid to Wheeler-Rex or any WHEELER-REX AUTHORIZED SERVICE CENTER. No tools are to be returned to the factory without receiving prior authorization. Obviously, failures due to misuse, abuse, or normal wear and tear are not covered by this warranty. **NO OTHER WARRANTY, WRITTEN, OR ORAL, APPLIES. THERE ARE NO WARRANTIES WHICH EXTEND BEYOND THE DESCRIPTION ON THE FACE HEREOF.** No employee, agent, dealer, or other person is authorized to give any warranty on behalf of Wheeler-Rex. Warranted products will be repaired or replaced at our option, at no charge and returned to you via prepaid transportation. Such replacement or repair is the exclusive remedy available from Wheeler-Rex. Wheeler-Rex is not liable for damage of any sort, including incidental and consequential damages. Some U.S.A. states do not allow the exclusion or limitation of incidental or consequential damages, so the above limitation or exclusion may not apply. This warranty gives you specific legal rights, and you may also have other rights which vary from state to state.

Form # 1031

# Guillotine Pipe Cutter

Model 1697

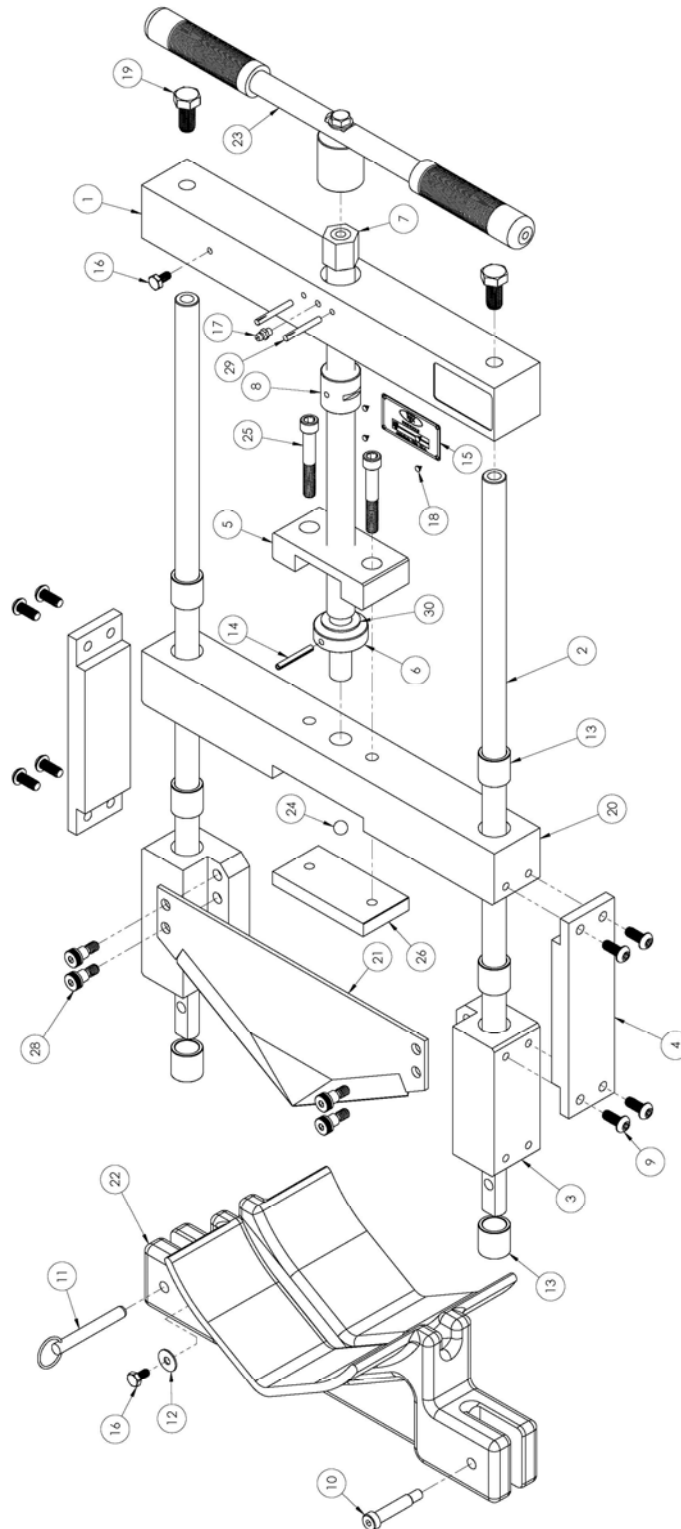

# Guillotine Pipe Cutter

Model 1697

Item	Part No	Description	Qty
1	701437	HEAD BAR	1
2	701430	GUIDE ROD	2
3	701436	BLADE BLOCK	2
4	701435	SIDE SUPPORT	2
5	701433	LIFT BLOCK	1
6	701319	COLLAR	1
7	701432	FEED SCREW ASSEMBLY	1
8	701362	ACME THR'D BUSHING	1
9	276527	5/16-18 x 3/4" SS BHCS	8
10	1907	SOCKET HEAD SHOULDER SCREW 3/8" X 1 1/2"	1
11	277197	2.3" COTTERLESS PIN w/ RING	1
12	276540	1/4" FLAT WASHER	1
13	277195	BEARING	6
14	275862	3/16" DIA x 1 1/2" ROLL PIN	1
15	700595	NAME PLATE	1
16	276536	1/4"-20 x 1/2 SS HHCS	2
17	277097	GREASE FITTING	1
18	276203	METAL TAK	4
19	276534	1/2"-13 x 1" SS HEX HEAD CAP SCREW	2
20	701434	BEARING BAR	1
21	701358	POINTED BLADE	1
22	701458	V-BASE-MACHINED	1
23	700674	HANDLE ASSEMBLY	1
24	277194	BALL BEARING	1
25	277231	3/8-16 x 2 1/2" LONG SHCS	2
26	701281	PRESSURE PLATE	1
27	276073	6" LANYARD ***NOT SHOWN***	1
28	277196	3/8 DIA x 3/8 LONG SHSS	4
29	277247	.187 dia GROOVED DOWEL PIN	2
30	1716	THRUST WASHER	1



Wheeler Rex ▪ 3744 Jefferson Road ▪ Ashtabula, OH 44004  
Tel: 800-321-7950 or 440-998-2788 ▪ Fax: 440-992-2925  
wheeler@wheelerrex.com ▪ www.wheelerrex.com

---