



Operating Instructions Models 46600 and 466000 Hydrostatic Test Pumps

Specifications

46600	
DIMENSIONS:	28" (70cm) L x 24" (60cm) W x 35" (87.5cm) H
WEIGHT:	136 lbs 62 kg
PUMP:	Triple diaphragm: Positive displacement Ports: 1" Inlet; ¾" NPT outlet Capacity: 15gpm, 57lpm Pressure: 0-300psi Operating Speed: 550rpm Lubrication: Pump: 23oz of Udor Lube or SAE30w Gear case: 16oz of 90W Gear Lube Shaft Size: 1"
ENGINE:	6.5hp Briggs & Stratton Intek Pro, 4 cycle, gasoline with 6-1 gear reduction
CONTROL:	Adjustable pressure relief valve
PULSATION CONTROL:	Pulsation dampener
GAUGE:	Glycerin filled, 0-600psi, 0-42kg
DISCHARGE HOSE:	¾" x 10' (3m) 1000psi rated
INTAKE HOSE:	1" x 10' (3m)



466000	
DIMENSIONS:	28" (70cm) L x 24" (60cm) W x 35" (87.5cm) H
WEIGHT:	136 lbs. 62 kg
PUMP:	Triple diaphragm: Positive displacement Ports: 1" Inlet; ¾" NPT outlet Capacity: 15gpm, 57lpm Pressure: 0-300psi Operating Speed: 550rpm Lubrication: Pump: 23oz of Udor Lube or SAE 30w Gear case: 16oz of 90W Gear Lube Shaft Size: 1"
ENGINE:	5.5hp Honda 4 cycle, gasoline with 6-1 gear reduction
CONTROL:	Adjustable pressure relief valve
PULSATION CONTROL:	Pulsation dampener
GAUGE:	Glycerin filled, 0-600psi, 0-42kg
DISCHARGE HOSE:	¾" x 10' (3m) 1000psi rated
INTAKE HOSE:	1" x 10' (3m)



Operating Instructions Models 46600 and 466000 Hydrostatic Test Pumps

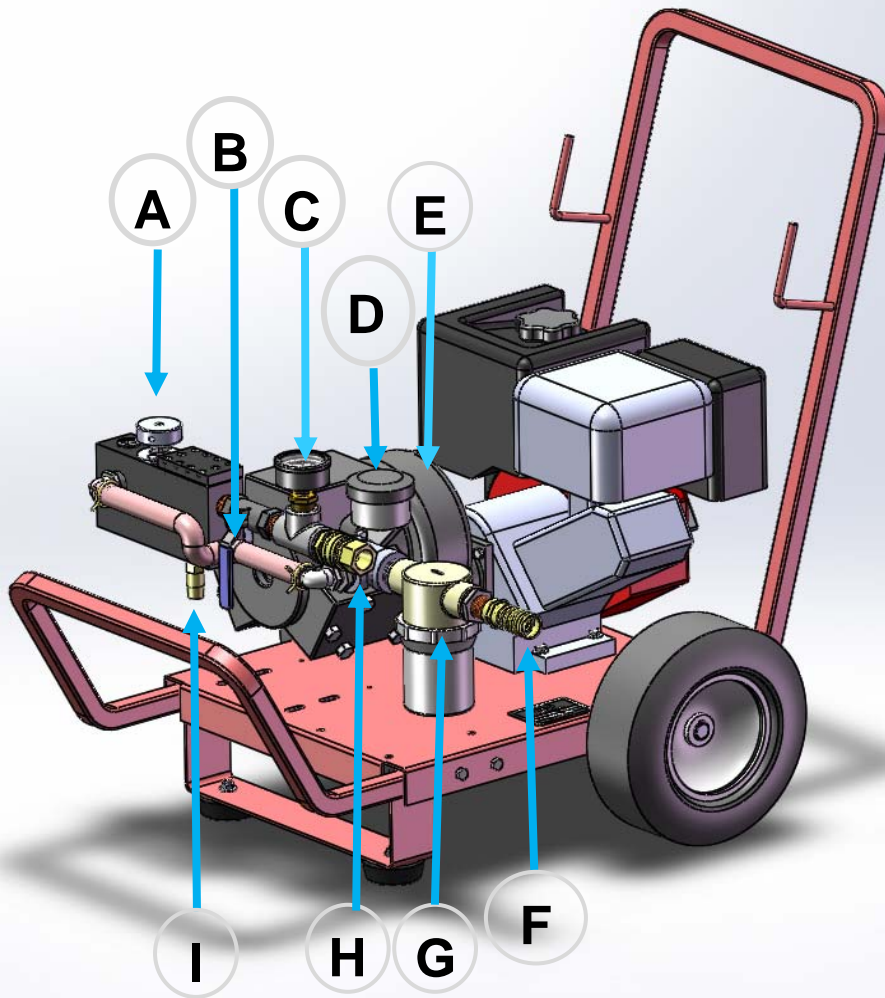

A	Pressure Relief Knob
B	Isolation Valve
C	Gauge
D	Pump Oil Reservoir
E	Gear Reduction
F	Inlet Connection
G	Strainer
H	Outlet Connection
I	Safety Valve



Operating Instructions Models 46600 and 466000 Hydrostatic Test Pumps

Gravity Feed: (Preferred Method)

1. Fill the water line (or test vessel) to be tested prior to pump connection.
2. Connect water supply hose to the garden hose inlet connection (F) on the pump.
3. Open valve and turn water supply on.
4. Purge the pump and pressure hose of all air.
5. Connect output (pressure) hose connection (H) between pump and water line (or vessel) being tested.
6. Turn pump on.
7. Purge water line (or vessel) of all air at the highest point of the system.
8. Bring water line (or vessel) to pressure. Watch the gauge (C) while pumping. When the desired pressure is achieved, turn the isolation valve (B) to the "off" position. The engine can now be turned off. If pressure drops, there is a leak in the line.



Siphon Method

Use a clean water source

1. Fill the water line to be tested.
2. Fill the intake hose (not supplied, Wheeler Rex PN 34550) with water, then quickly place the hose into a bucket and turn pump on. (Unit is self-priming once primed). Continue to run pump until you see the water coming out of the outlet hose, with little or no air mixed with it.
3. Connect the output hose to the water line. Continue on with steps 6 through 8 in Gravity Feed Method.



Operating Instructions Models 46600 and 466000 Hydrostatic Test Pumps

Pre-Setting Your Pump

Your pump can be pre-set to a specific pressure easily by adjusting the pressure relief valve.

1. Unscrew (counterclockwise direction) pressure relief valve knob (A) until it stops. Your pump will now be at 0 (zero) psi.
2. Add a ball valve (not supplied with pump) to the end of the high pressure hose.
3. Follow steps 2 through 4 from the 'Pressure / Gravity Feed Method' above.
4. As water is flowing out of the high pressure hose, turn the ball valve to the off position.
5. Slowly start turning pressure relief valve knob (A) in the clockwise direction by $\frac{1}{4}$ turn increments, until you reach the desired pressure. When the knob is turned in all the way, the maximum pressure is achieved (300psi).
6. Your test pump is now pre-set. This eliminates over-pressurizing the water line (or the vessel).



Operating Instructions Models 46600 and 466000 Hydrostatic Test Pumps

Troubleshooting Your Pump

Test pressure not being reached:

- Possible air in line (or vessel).
 - ◊ Air needs to be purged from system.
 - ◊ Remove pump from system and follow steps 1 through 6 of the "Pre-setting Your Pump" section.
 - ◊ If using the Siphon Method and not getting pressure, try the "Gravity Feed Method" to ensure water is getting into the pump.
 - ◊ Check strainer (G) O-Ring for cracks.
 - ◊ Check inlet connection (F) O-Ring for cracks.
- Pressure relief valve (A) not adjusted properly.
 - ◊ Turn relief valve counterclockwise and watch gauge (C) for change in pressure.

Pump Maintenance

- Pump 50/50 antifreeze/water solution through pump after each use to avoid freezing and to lubricate pump.
- Check strainer O-Ring (G) for cracks prior to each use.
- Check and change engine oil per manufacturers specifications.
- Gear reduction Gear Lube. Check and change per manufacturers specifications.
- Check pump oil level (D) prior to each use.
- Check gear reduction (E) oil prior to each use.
- Change gear reduction (E) oil per manufacturers specifications.
- Pump repair kit (Wheeler Rex PN 36347)
- Suction Hose (Wheeler Rex PN 34550)

Safety Valve

- Safety Valve is designed to "pop off" or bleed off any extra pressure.

CAUTION !!!
This pump is designed for water only!!

The pump is equipped with an adjustable pressure relief valve (A), which helps protect the system from being over pressurized. It can be preset by plugging the end of the hose. Turn the adjusting knob clockwise to increase pressure and counterclockwise to decrease.

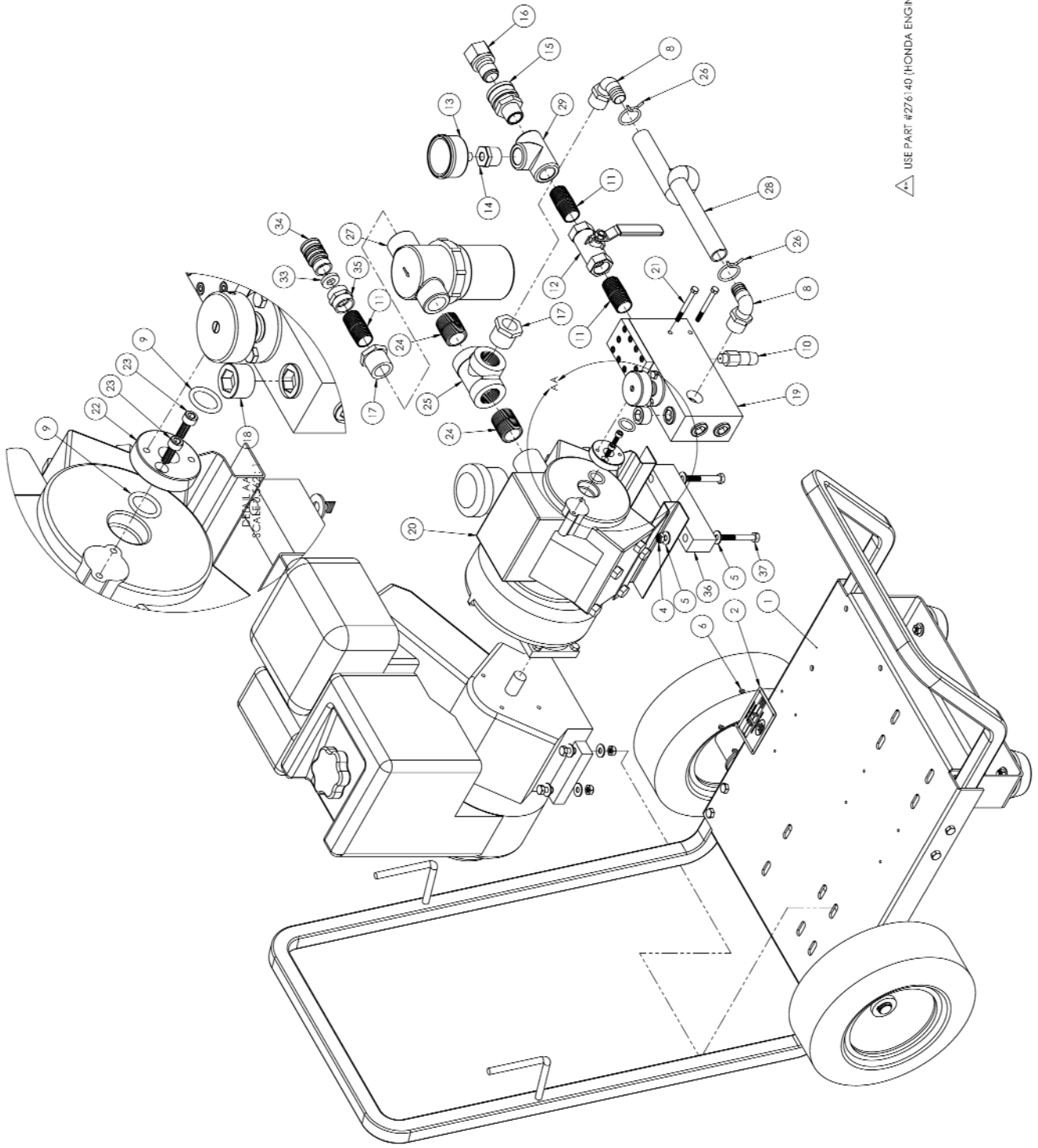

▲ USE PART #276-140 (HONDA ENGINE) FOR PUMP ASSEMBLY #466000



15 GPM/300 PSI TEST PUMP

PART NO.

46600

Item	Part No	Description	Qty
1	700136	PUMP CART	1
2	220874	NAME PLATE	1
3	275638	5/16 x 1 1/2" HEX HEAD CAP SCREW	4
4	275857	5/16-18 HEX NYLON INSERT LOCKNUTS	6
5	275685	5/16" FLAT WASHER	12
6	275543	POP RIVET, STAR 4-2AAD	4
7	275684	6.5 HP BRIGGS & STRATTON ENGINE	1
8	276116	3/4 MP x 3/4 MH 90 DEG HOSE BARB	2
9	276111	O-RING	2
10	275950	SAFETY VALVE, CAT 30960	1
11	276102	3/4" BRASS CLOSE NIPPLE	3
12	275927	3/4" BALL VALVE	1
13	36359	0-600 PSI GAUGE	1
14	276108	3/4" x 1/4" BRASS REDUCER BUSHING	1
15	276100	PH QD FEM HLF BST-6M	1
16	276101	PH QD MALE HALF BST N6	1
17	276103	1" x 3/4" HEX REDUCER BUSHING	2
18	276406	3/4" NPT PIPE PLUG	1
19	700896	MANIFOLD ASSEMBLY	1
20	276352	KAPPA 55 TIPPLE DIAPHRAM PUMP	1
21	276109	M6 x 60MM HEX HEAD CAP SCREW	2
22	700171	ADAPTER	1
23	600131	6 X 16mm SOCKET HEAD CAP SCREW	2
24	276354	1" CLOSE NIPPLE	2
25	276353	1" TEE	1
26	276105	HOSE CLAMP, 1 1/8" OD RC HC-18S	2
27	276355	STRAINER ASSEMBLY	1
28	700930	BY-PASS HOSE	1
29	275644	3/4" TEE	1
30	277181	WARNING TAG ***NOT SHOWN***	1
31	221065	PRESSURE HOSE ***NOT SHOWN***	1
32	34550	SUCTION HOSE ***NOT SHOWN***	1
33	275941	HOSE WASHER	1
34	276099	3/4" HOSE QUICK DISCONNECT	1
35	275874	3/4" FH x 3/4" FP ADAPTER	1
36	701506	PUMP SPACER BLOCK	1
37	276736	5/16-18 x 2 1/4" L HHCS	2

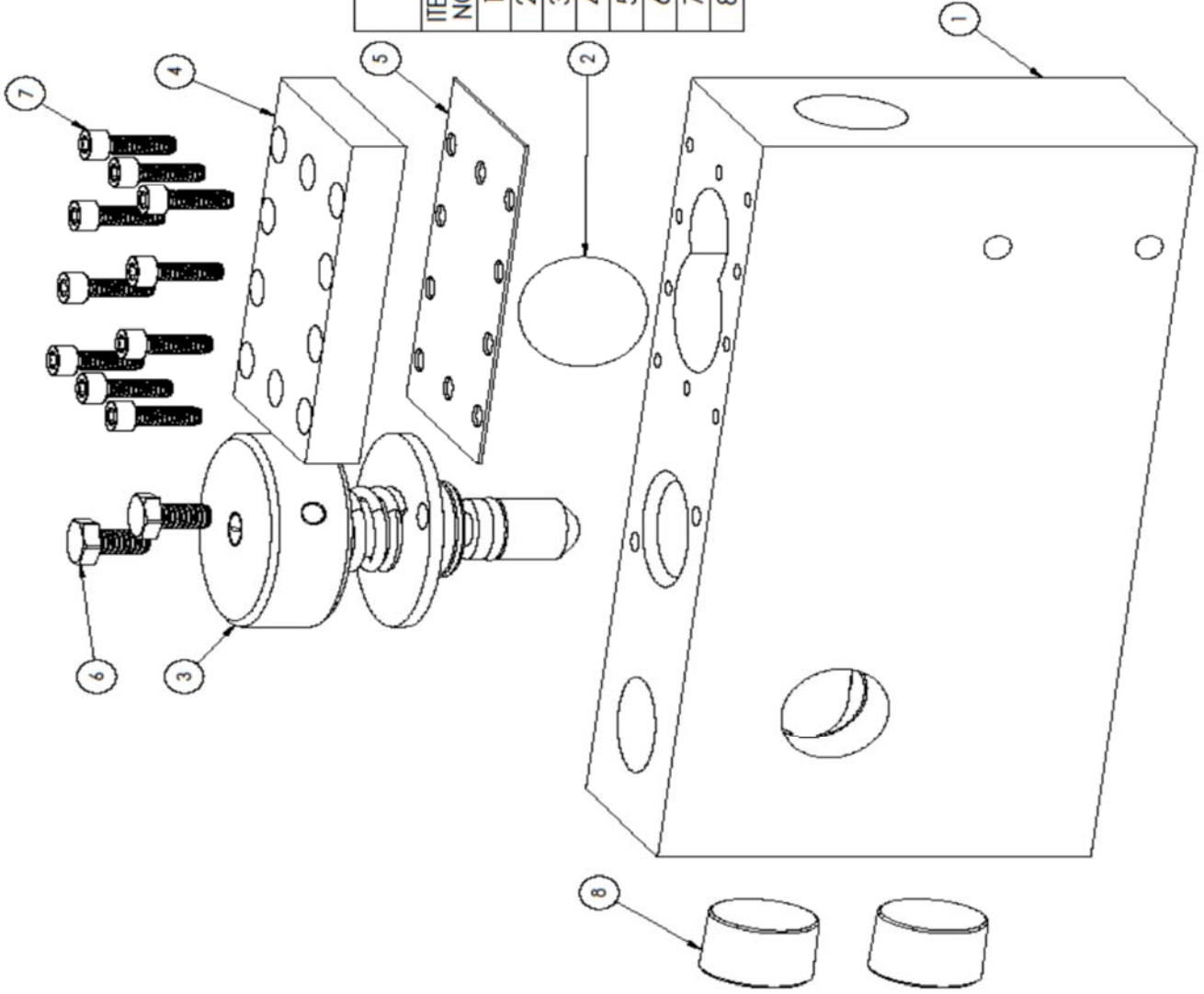

700898 MANIFOLD ASSEMBLY			
ITEM NO.	PART NUMBER	DESCRIPTION	QTY.
1	700895	MANIFOLD	1
2	276098	1 1/8" SS BALL	1
3	700887	SPOOL ASSEMBLY	1
4	700124	MANIFOLD LID	1
5	700232	GASKET	1
6	276536	1/4"-20 x 1/2 SS HEX HEAD CAP SCREW	2
7	275070	#10-24 x 5/8" SHCS	10
8	276406	3/4" NPT PIPE PLUG	2



700896 Manifold Assembly



WHEELER-REX LIMITED LIFETIME WARRANTY

WHEELER-REX covers its products with a Limited Lifetime Warranty, with exception of pipe threading machines which have a Limited Three Year Warranty (including electric motors). Warranties from manufacturers of components used in our products may pre-empt the Wheeler-Rex warranty. Wheeler-Rex warrants against defects in material or workmanship. To take advantage of this warranty, the complete product must be delivered prepaid to Wheeler-Rex or any WHEELER-REX AUTHORIZED SERVICE CENTER. No tools are to be returned to the factory without receiving prior authorization. Obviously, failures due to misuse, abuse, or normal wear and tear are not covered by this warranty. **NO OTHER WARRANTY, WRITTEN, OR ORAL, APPLIES. THERE ARE NO WARRANTIES WHICH EXTEND BEYOND THE DESCRIPTION ON THE FACE HEREOF.** No employee, agent, dealer, or other person is authorized to give any warranty on behalf of Wheeler-Rex. Warranted products will be repaired or replaced at our option, at no charge and returned to you via prepaid transportation. Such replacement or repair is the exclusive remedy available from Wheeler-Rex. Wheeler-Rex is not liable for damage of any sort, including incidental and consequential damages. Some U.S.A. states do not allow the exclusion or limitation of incidental or consequential damages, so the above limitation or exclusion may not apply. This warranty gives you specific legal rights, and you may also have other rights which vary from state to state.

Form # 1031

WARNING

GENERAL TOOL OPERATION WARNINGS

FOR ALL TOOLS-

1. **Keep Guards in Place** and in working order.
2. **Remove Adjusting Keys and Wrenches** from tool before turning it on.
3. **Keep Work Area Clean.** Cluttered areas and benches invite accidents.
4. **Avoid Dangerous Environment.** Don't use power tools in damp or wet locations. Keep work area well lit. Don't expose power tools to rain.
5. **If you must use an electric tool** in a damp or wet location; make sure it is plugged into a circuit which is protected by a ground fault interrupt.
6. **Keep Children Away. ALL VISITORS SHOULD BE KEPT A SAFE DISTANCE FROM WORK AREA.**
7. **Store Idle Tools** in dry, high, or locked-up place out of reach of children.
8. **Don't Force Tool.** It will do a better and safer job at the rate for which it is designed.
9. **Use Right Tool.** Don't force a small tool or attachment to do the job of a heavy-duty tool.
10. **Wear Proper Apparel.** No loose clothing or jewelry to get caught in moving parts. Rubber gloves and footwear are recommended when working outdoors.
11. **Use Safety Glasses.**
12. **Don't Abuse Cord.** Never carry tool by cord or yank it to disconnect from receptacle. Keep cord from heat, oil, and sharp edges.
13. **Secure Work.** Use clamps or vise to hold work when practical. It's safer than using your hand and it frees both hands to operate tool.
14. **Don't Overreach.** Keep proper footing and balance at all times.
15. **Maintain Tools Properly.** Keep tools sharp and clean for best and safest performance. Follow instructions for lubricating and changing accessories. Equipment operators must have proper maintenance & instruction sheets. Be sure the tool operator reads and understands this information. If you don't have current maintenance and instruction sheets, contact the factory & we will supply them at no charge.
16. **Disconnect Tools** when not in use; before servicing; when changing accessories such as dies, cutters, etc.
17. **Avoid Accidental Starting.** Don't carry plugged-in tool with finger on switch. Be sure switch is off when plugging in.
18. **Outdoor Use Extension Cords.** When tool is used outdoors, use only extension cords suitable for use outdoors and so marked.
19. **Wear Ear Protection** if exposed to long periods of very noisy shop operations.
20. **Do not operate** tools while under the influence of alcohol, drugs or medication.



Wheeler Rex ▪ 3744 Jefferson Road ▪ Ashtabula, Ohio 44005
Tel: 800-321-7950 or 440-998-2788 ▪ Fax: 440-992-2925
wheeler@wheelerrex.com ▪ www.wheelerrex.com